

# CS1

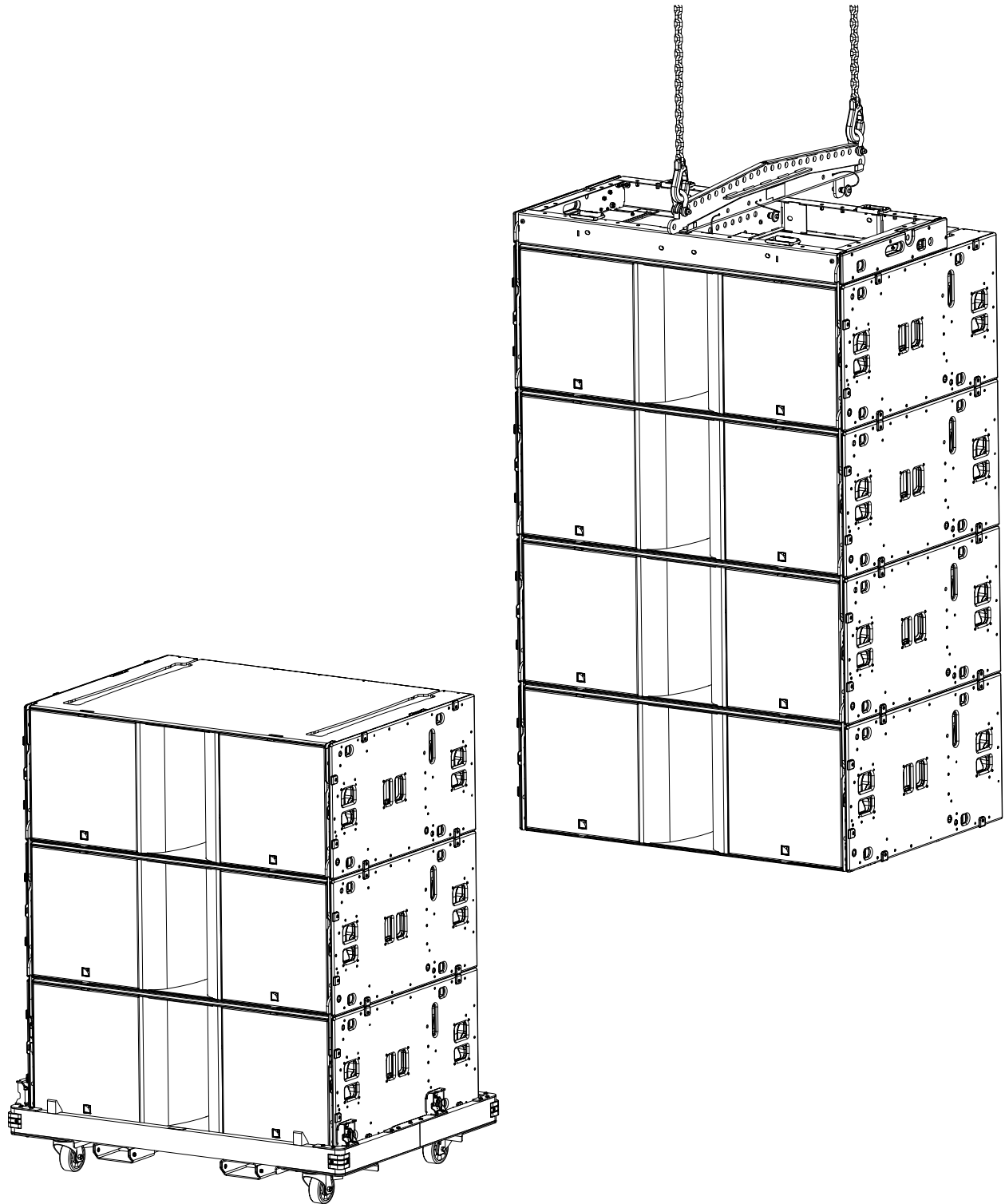

## owner's manual (EN)



Document reference: CS1 owner's manual (EN) version 2.0

Distribution date: May 21, 2026

© 2026 L-Acoustics. All rights reserved.

No part of this publication may be reproduced or transmitted in any form or by any means without the express written consent of the publisher.

## Contents







Safety.....	5
Instructions.....	5
Introduction.....	7
CS1 Large Format Cardioid Subwoofer 4 x 21" LF.....	7
How to use this manual.....	8
Revision history.....	8
System components.....	9
Electro-acoustical description.....	13
Polar pattern.....	13
Preset description.....	14
Connectors.....	15
Rigging system description.....	16
CS1.....	16
Rigging elements.....	19
L1-BUMP.....	19
L1-BAR.....	22
CS1-BUMP.....	23
CS1-BAR.....	26
L1CS1-RAKMOUNT.....	27
CLAMP1000.....	28
K1-DELTA.....	29
Storage and handling.....	30
CS1-PLA.....	30
CS1-COV.....	31
CS1-CHARIOT.....	32
CS1-CHARIOTCOV.....	33
L1CS1-BUMPFLIGHT.....	34
Mechanical safety.....	35
Loudspeaker configurations.....	37
Rigging procedures.....	39
Preparing CS1-BUMP for rigging.....	39
Securing LA-RAK III / LA-RAK II AVB on CS1-BUMP with L1CS1-RAKMOUNT.....	43
Flying.....	49
Flying CS1.....	49

Adding CS1 to an array.....	53
Removing CS1 from an array using CS1-PLA.....	57
Removing CS1 from an array using CS1-CHARIOT.....	60
Stacking.....	63
Stacking CS1 on CS1-CHARIOT.....	63
Connection to LA amplified controllers.....	72
Corrective maintenance.....	73
Introduction.....	74
Exploded views.....	74
Disassembly and Reassembly procedures.....	75
Specifications.....	87
CS1.....	87
CS1-BUMP.....	89
CS1-BAR.....	90
L1-BUMP.....	91
L1-BAR.....	92
L1CS1-RAKMOUNT.....	93
CLAMP1000-BASE.....	94
CLAMP1000-SINGLE.....	95
CLAMP1000-DUAL.....	96
CS1-CHARIOT.....	98
CS1-PLA.....	100
L1-BUMPFLIGHT.....	101
L1CS1-BUMPFLIGHTADDLAYER.....	102
APPENDIX: Recommendation for speaker cables.....	103
APPENDIX: Installing a laser inclinometer.....	104
L1-BUMP and CS1-BUMP.....	104

# Safety

## Instructions

---

-  **Inspect the system before any deployment.**  
Perform safety related checks and inspections before any deployment.
- Perform preventive maintenance at least once a year.**  
Refer to the preventive maintenance section for a list of actions and their periodicity.  
Insufficient upkeep of the product can void the warranty.
- If any safety issue is detected during inspection, do not use the product before performing corrective maintenance.**  
Check for issues. A rigging system part or fastener is missing or loose. A rigging system part exhibits: bends, breaks, broken parts, corrosion, cracks, cracks in welded joints, deformation, denting, wear, holes. A safety cue or label is missing.
-  **Never incorporate equipment or accessories not approved by L-Acoustics.**
-  **Read all the related PRODUCT INFORMATION documents shipped with the products before exploiting the system.**
-  **Do not store the product on an unstable cart, stand, tripod, bracket, or table.**
-  **Beware of sound levels.**  
Do not stay within close proximity of loudspeakers in operation.  
Loudspeaker systems are capable of producing very high sound pressure levels (SPL) which can instantaneously lead to permanent hearing damage to performers, production crew, and audience members. Hearing damage can also occur at moderate level with prolonged exposure to sound.  
Check the applicable laws and regulations relating to maximum sound levels and exposure times.
-  **Work with qualified personnel for rigging the system.**  
Installation should only be carried out by qualified personnel that are familiar with the rigging techniques and safety recommendations outlined in this manual.
- Ensure personnel health and safety.**  
During installation and set-up personnel must wear protective headgear and footwear at all times. Under no circumstances is personnel allowed to climb on a loudspeaker assembly.
- Respect the Working Load Limit (WLL) of third party equipment.**  
L-Acoustics is not responsible for any rigging equipment and accessories provided by third party manufacturers. Verify that the Working Load Limit (WLL) of the suspension points, chain hoists and all additional hardware rigging accessories is respected.
- Respect the maximum configurations and the recommended safety precautions.**  
For safety reasons, respect the maximum configurations outlined in this manual. To check the conformity of any configuration in regards with the safety precautions recommended by L-Acoustics, model the system in Soundvision and refer to the warnings in Mechanical view.
- Be cautious when flying a loudspeaker configuration.**  
Before installing/raising the product, check each individual element to make sure that it is securely fastened to the adjacent element. Always verify that no one is standing underneath the product when it is being installed/raised. Never leave the product unattended during the installation process.  
As a general rule, L-Acoustics recommends the use of secondary safety at all times.
- Be cautious when ground-stacking a loudspeaker array.**  
Do not stack the loudspeaker array on unstable ground or surface. If the array is stacked on a structure, platform, or stage, always check that the latter can support the total weight of the array.  
As a general rule, L-Acoustics recommends the use of safety straps at all times.

### **Risk of falling objects**

Verify that no unattached items remain on the product or assembly.

### **Risk of tipping**

Remove all rigging accessories before transporting a product or an assembly.

### **Take into account the wind effects on dynamic load.**

When a loudspeaker assembly is deployed in an open air environment, wind can produce dynamic stress to the rigging components and suspension points.

If the wind force exceeds 6 bft (Beaufort scale), lower down and/or secure the product or the assembly.



### **Intended use**

This system is intended for use by trained personnel for professional applications.



**As part of a continuous evolution of techniques and standards, L-Acoustics reserves the right to change the specifications of its products and the content of its documents without prior notice.**

Check [www.l-acoustics.com](http://www.l-acoustics.com) on a regular basis to download the latest document and software updates.



**Long term exposure to extreme conditions may damage the product.**

For more information, refer to the **Products weather protection** document, available on the website.



**Read the maintenance section of this document before servicing the product.**



**Contact L-Acoustics for advanced maintenance.**

Any unauthorized maintenance operation will void the product warranty.



This marking indicates that this product should not be disposed of with other household waste throughout the EU. To prevent possible harm to the environment or human health from uncontrolled waste disposal, recycle it responsibly to promote the sustainable reuse of material resources. To return your used device, please use the return and collection systems or contact the retailer where the product was purchased. They can take this product for environmentally safe recycling.



## Introduction

### **CS1 Large Format Cardioid Subwoofer 4 x 21" LF**

---



CS1 is a large format cardioid subwoofer designed to deliver extended low frequency response and broadband pattern control for the most demanding applications. Engineered with the L-Acoustics patented cardioid architecture, CS1 delivers powerful, linear low end while minimizing energy behind the array.

With bandwidth extending down to 25 Hz and a maximum SPL of 150 dB, CS1 provides the depth and headroom required for today's largest productions. Four 21" transducers are arranged in a cardioid topology, two forward-facing and one on each side, producing powerful low end while achieving broadband rear rejection that keeps stages clear and reduces unwanted spill. Dedicated presets offer cardioid and supercardioid modes and additional side rejection, allowing users to orient maximum rejection directly behind the array or across the stage according to the needs of the venue.

Mechanical compatibility with the L1 system allows CS1 to be flown within the array to extend line length and reinforce low frequency directivity, or ground-stacked to increase contour and overall output. Whether deployed independently or as part of the flagship L Series, CS1 combines impact, precision, and deployment flexibility for stadiums, arenas, and festival main stages.

## How to use this manual

---

The CS1 owner's manual is intended for all actors involved in the system design, implementation, preventive and corrective maintenance of the CS1 system. It must be used as follows:

1. Read the technical description for an overview of all system elements, their features, and their compatibilities.
  - [Electro-acoustical description](#) (p.13)
  - [Rigging system description](#) (p.16)
2. Prepare the system configuration. Consider the mechanical limits and the available acoustical configurations.
  - [Mechanical safety](#) (p.35)
  - [Loudspeaker configurations](#) (p.37)
3. Before rigging the system, perform mandatory inspections and functional checks.
4. To deploy the system, follow the step-by-step rigging instructions and refer to the cabling schemes.
  - [Rigging procedures](#) (p.39)
  - [Connection to LA amplified controllers](#) (p.72)



The [Corrective maintenance](#) (p.73) section contains the operations authorized for the end user.

Performing another operation exposes to hazardous situations.

For advanced maintenance, contact your L-Acoustics representative.

**As part of a continuous evolution of techniques and standards, L-Acoustics reserves the right to change the specifications of its products and the content of its document without prior notice.** Please check [www.l-acoustics.com](http://www.l-acoustics.com) on a regular basis to download the latest document and software updates.

### Contact information

For information on advanced corrective maintenance:

- Contact your Certified Provider or your L-Acoustics representative.
- For Certified Providers, contact the L-Acoustics customer service: [customer.service@l-acoustics.com](mailto:customer.service@l-acoustics.com) (EMEA/APAC), [laus.service@l-acoustics.com](mailto:laus.service@l-acoustics.com) (Americas).

### Symbols

The following symbols are used in this document:



This symbol indicates a potential risk of harm to an individual or damage to the product.

It can also notify the user about instructions that must be strictly followed to ensure safe installation or operation of the product.



This symbol notifies the user about instructions that must be strictly followed to ensure proper installation or operation of the product.



This symbol notifies the user about complementary information or optional instructions.

### Revision history

---

version number	publication date	modification
1.0	Nov. 2025	Initial version.
2.0	May 2026	Various fixes and improvements.

## System components

### Loudspeaker enclosures

CS1                      Cardioid subwoofer 4 × 21"

### Powering and driving system

LA12X                    Amplified controller 4 × 2600 W / 4 ohms

LA7.16                    Amplified controller 16 × 1300 W / 8 ohms

LA7.16i                    Install-specific amplified controller 16 × 1300 W / 8 ohms



Refer to the LA12X / LA7.16 / LA7.16i owner's manual for operating instructions.

### Racks

LA-RAK II AVB            Touring rack containing three LA12X, LA-POWER II for power distribution, LA-PANEL II for audio and network distribution, and two LS10 for AVB distribution

LA-RAK III                Touring rack containing three LA7.16, one LA-POWER II for power distribution, one LA-PANEL III for audio signal distribution, and two LS10 for AVB distribution

### Cables

DO cables                PA-COM loudspeaker cables (8-point, 4 mm<sup>2</sup> gauge)  
Come in different sizes: DO.7 (0.7 m / 2.3 ft), DO.10 (10 m / 32.8 ft), and DO.25 (25 m / 82 ft)

SC32-4DO                Breakout cable  
SC32 connector to 4 × 8-point CA-COM



**Information about the connection of the enclosures to the LA amplified controllers is given in this document.**

Refer to the LA12X / LA7.16 / LA7.16i owner's manual for detailed instructions about the whole cabling scheme, including modulation cables and network.

### Rigging elements

L1-BUMP                 Flying frame for L1(D) and CS1 (incl. L1CS1-RAKMOUNT, 1 extension sling and 1 laser adapter)

L1-BAR                    Extension bar for L1-BUMP

CS1-BUMP                Flying frame for L1(D) and CS1 (incl. 1 extension sling + 1 laser adapter)

CS1-BAR                 Extension bar for CS1-BUMP and L1-BUMP

L1CS1-RAKMOUNT      4 mounting cradles for LA-RAK III (incl. rack stabilizer)

CLAMP1000              Rotary clamp certified for 1000 kg / 2205 lb (includes base, single-point and dual-point mounting adaptors)

K1-DELTA                Azimuth angle tuning accessory

### Transportation accessories

CS1-PLA                 Removable front dolly for one CS1

CS1-COV                 Protective cover for one CS1

CS1-CHARIOT            Chariot for up to four CS1

CS1-CHARIOTCOV      Protective cover for up to three CS1 on CS1-CHARIOT

L1CS1-BUMPFLIGHT Modular flightcase for 2 L1-BUMP/CS1-BUMP and rigging elements

L1CS1-BUMPFLIGHT extension for one additional L1-BUMP/CS1-BUMP  
 BUMPFLIGHTADDLAYER

**Software applications**

Soundvision 3D acoustical and mechanical modeling software

LA Network Manager Software for remote control and monitoring of amplified controllers

**i** Refer to the Soundvision help.  
**i** Refer to the LA Network Manager help.

**System component illustrations**

**Cables**

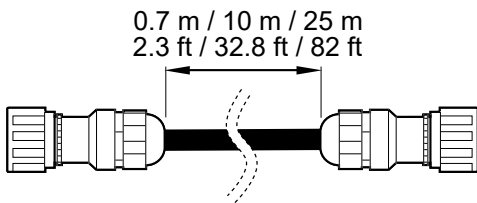

DO cables

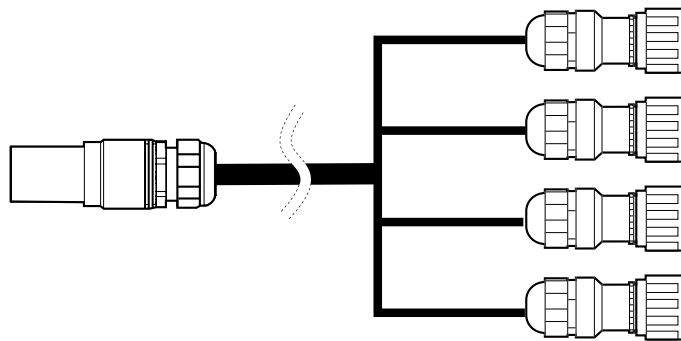

SC32-4DO

**Rigging accessories**

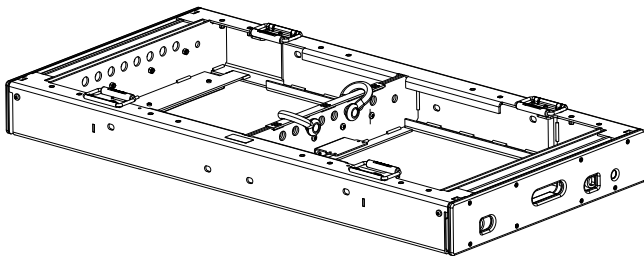

L1-BUMP

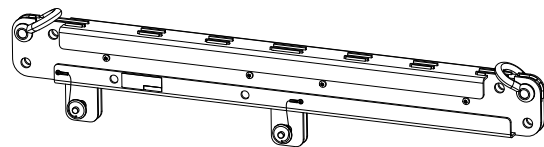

L1-BAR

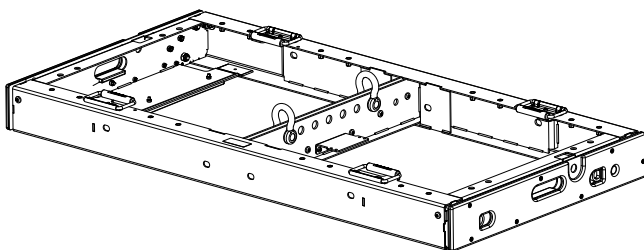

CS1-BUMP

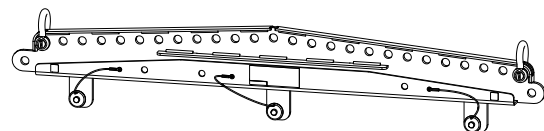

CS1-BAR

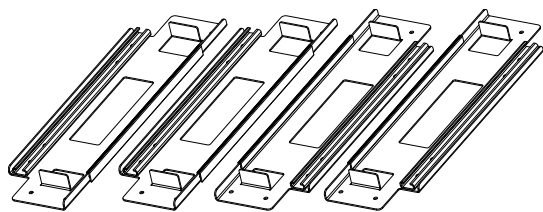

L1CS1-RAKMOUNT

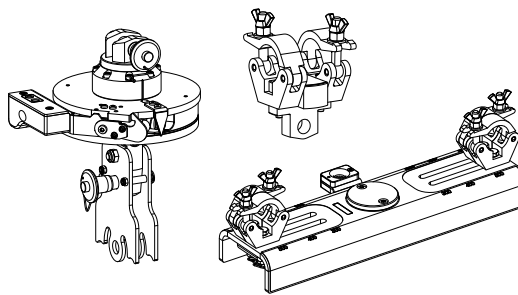

CLAMP1000

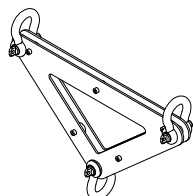

K1-DELTA

### Software applications

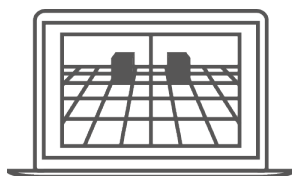

Soundvision



LA Network Manager

### Transportation

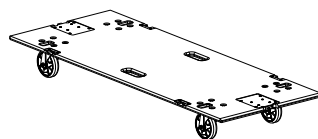

CS1-PLA

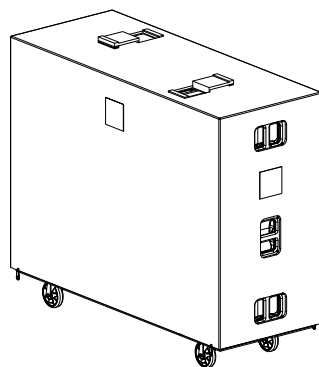

CS1-COV

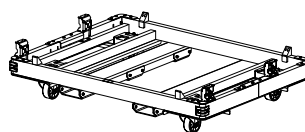

CS1-CHARIOT

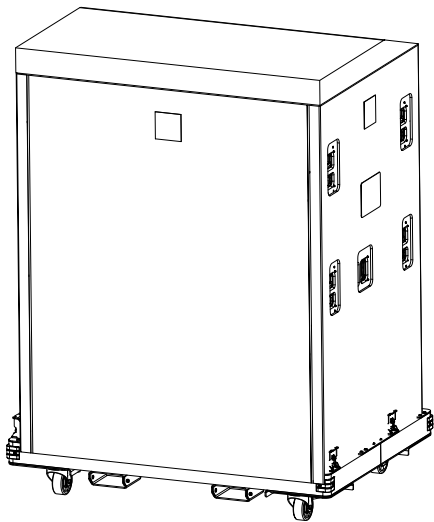

CS1-CHARIOTCOV

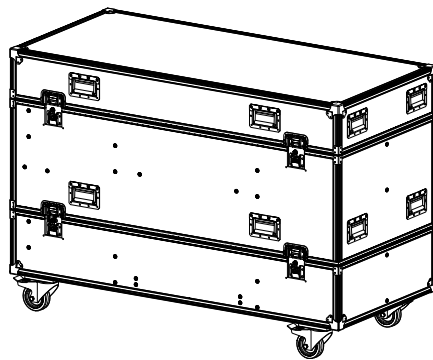

L1CS1-BUMPFLIGHT

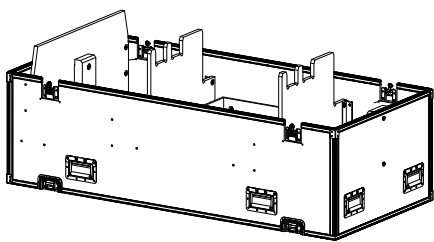

L1CS1-BUMPFLIGHTADDLAYER

## Electro-acoustical description

### Polar pattern

CS1 features the following low frequency loudspeakers:

- Two low frequency loudspeakers (SB<sup>\*</sup>) at the front.
- Two low cardioid loudspeakers (SC<sup>\*\*</sup>) on the sides.

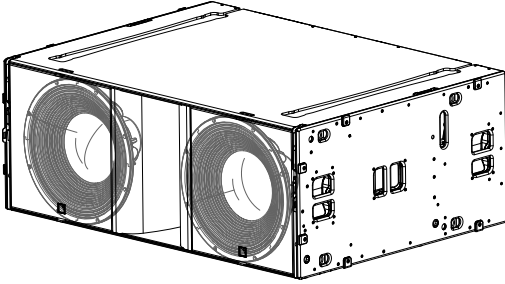

CS1 low frequency loudspeakers

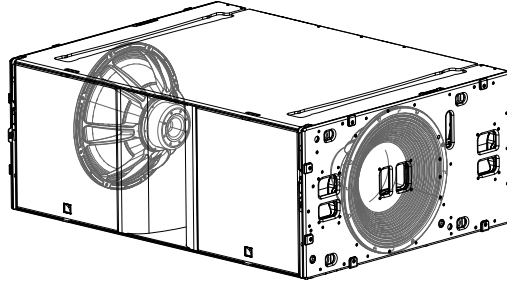

CS1 low cardioid loudspeakers

The low cardioid loudspeakers allow a standard array to exhibit a broadband cardioid pattern that minimizes rear SPL at low frequencies. Alternatively, and with the appropriate presets, the array can exhibit a supercardioid pattern that minimizes side SPL at low frequencies.

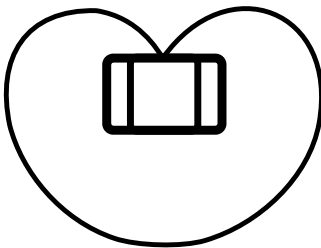

cardioid pattern  
(preset [CS1\_xx])

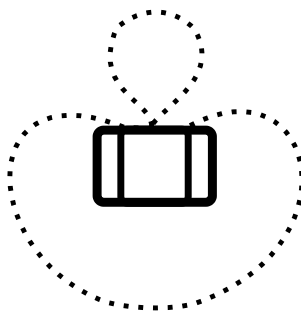

supercardioid pattern  
(preset [CS1\_xx\_S])

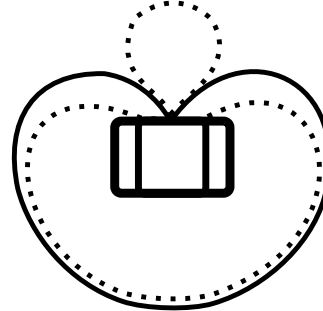

pattern comparison

\* SB: subwoofer loudspeakers in a standard configuration.

\*\* SC: subwoofer loudspeakers in a cardioid configuration.

## Preset description

---

The preset selection process varies depending on the amplified controller type.

### 4-output amplified controllers

On compatible 4-output amplified controllers, select the preset from the preset selector.

**i** Use the table to identify which user parameters can be set on individual channels and which are linked together.

#### [CS1\_60] [CS1\_60\_S]

channel number	channel name	routing	gain	delay	polarity	mute
1	SC	IN A	0 dB	0 ms	+	ON
2	SB					ON
3	SB					ON
4	SC					ON

### 16-output amplified controllers

On compatible 16-output amplified controllers, add the enclosure set to the preset layout, then choose the preset options for each loudspeaker or loudspeaker module inside the enclosure set.

**i** Use the enclosure set table to identify which user parameters can be set on individual channels and which are linked together.

#### CS1

##### CS1 enclosure set

channel number	channel name	routing	gain	delay	polarity	mute
1	SC	IN 1	0 dB	0 ms	+	ON
2	SB					ON
3	SB					ON
4	SC					ON

##### CS1 presets

preset option	CS1 preset
[CS1]	[CS1_60]
	[CS1_X]
[CS1_S]	[CS1_60_S]
	[CS1_X_S]

## Connectors

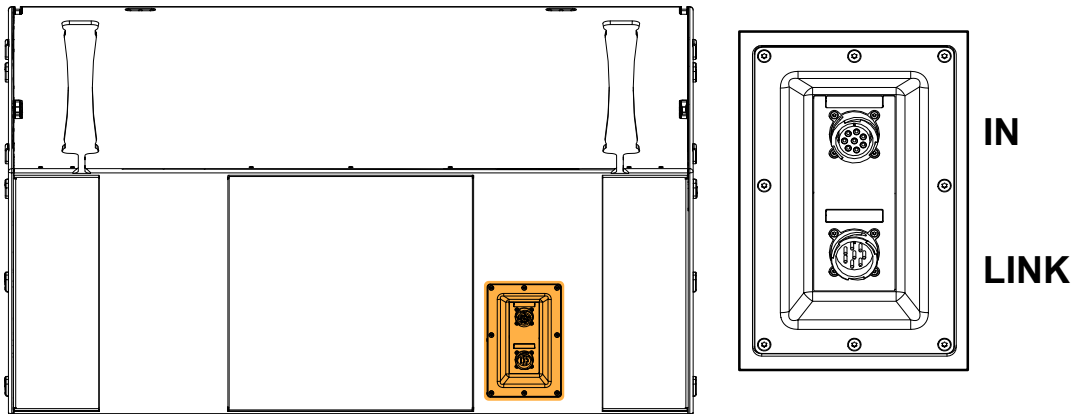

CS1

2 × 8-point PA-COM

### Internal pinout for L-Acoustics active 4-channel subwoofers

connector points	Transducer connectors
A/B	LF1
C/D	LF2
E/F	LF3
G/H	LF4

viewed from the front

## Rigging system description

### CS1

On both sides, CS1 integrates two arms to connect another element of the rigging system, such as an enclosure or a flying frame:

- At the front, two rotating arms enable the connection to front rigging points.
- At the rear, two sliding arms enable the inter-element rear connection.

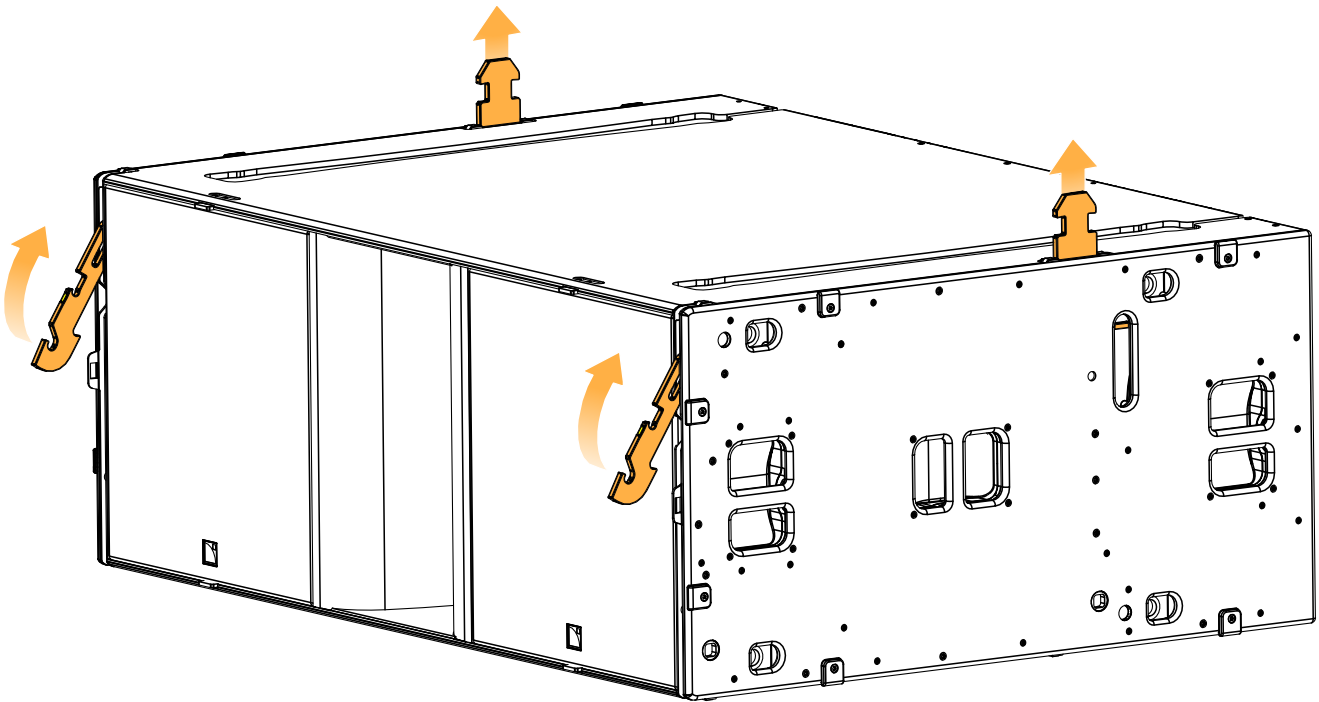

All elements of an array are secured by an automatic system with buttons and latches. The system is activated in advance and locks itself during the lifting procedures.

The rigging elements and latches are fitted with yellow safety labels that are visible when they are not safely locked.

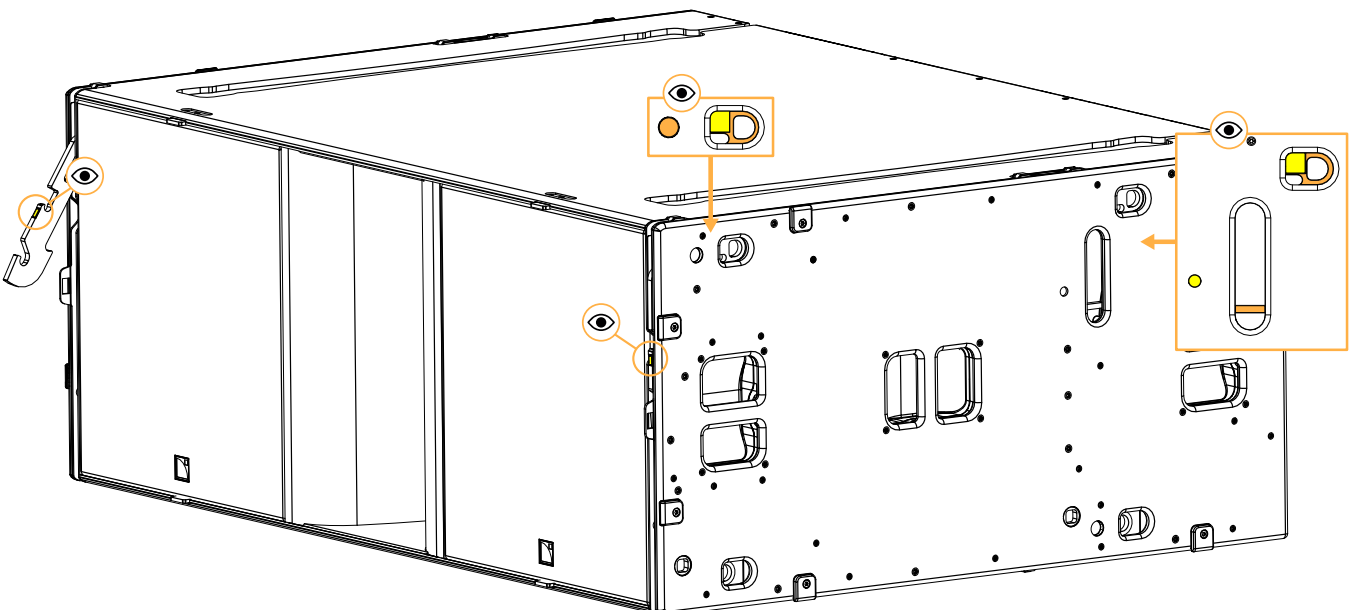

CS1 has two ground runners on the bottom that match with tracks on top of other CS1.

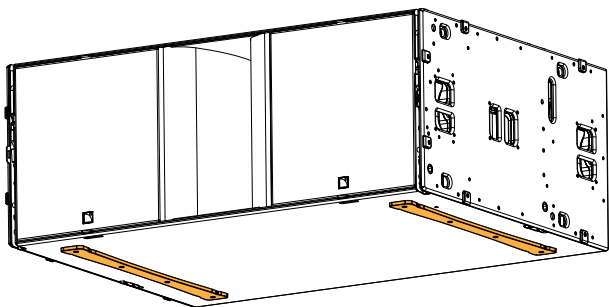

CS1 ground runners

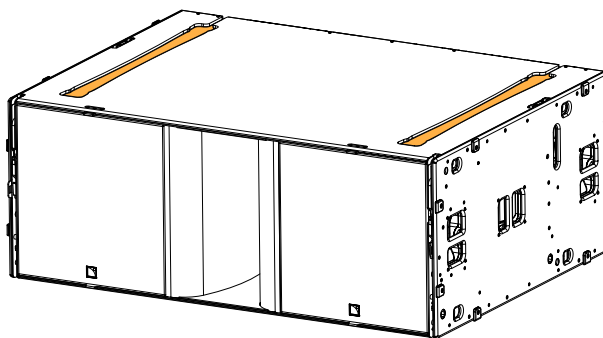

CS1 matching tracks

Three ergonomic handles on each side of the enclosure are available for handling.

Use the handles to hold the enclosure or to tip CS1 over and put CS1-PLA on its wheels. See [CS1-PLA](#) (p.30).

**! Heavy load: one CS1 weighs 180 kg (without rigging accessories or cables)**  
 CS1 must be lifted by a lifting device.

**! Risk of injury**  
 A minimum of two operators is required to handle CS1 when using a motor.

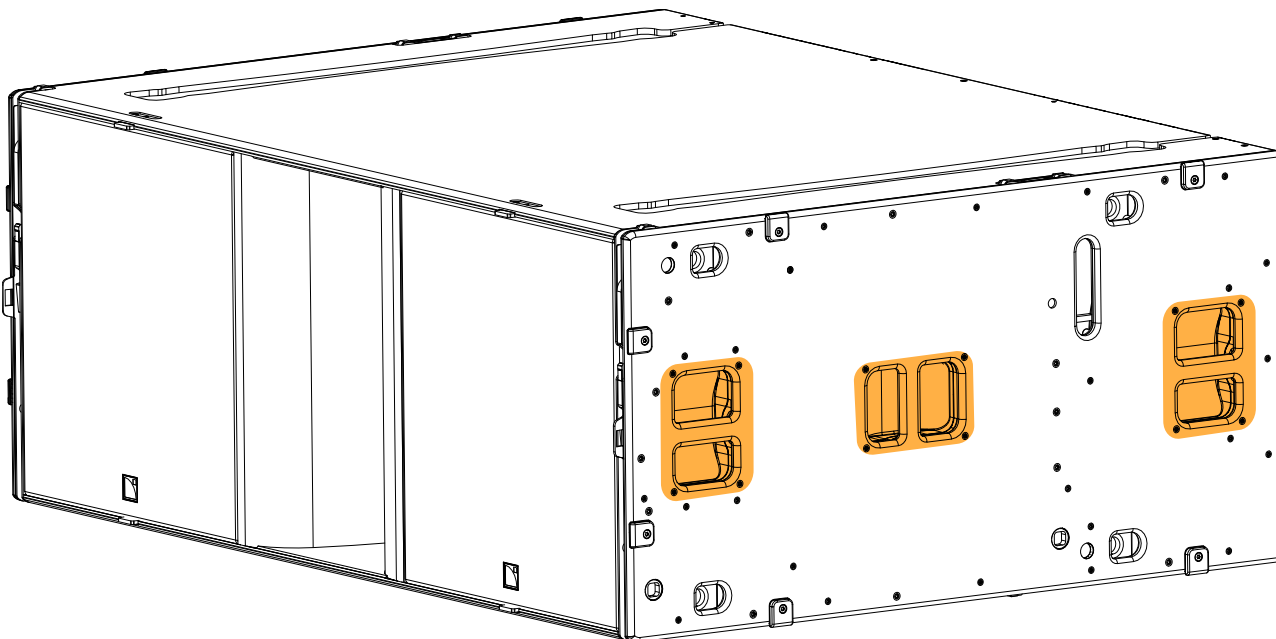

Three drain screws at the bottom of CS1 are available for draining.

If exposed to water, remove the three M6×16 screws to drain the cabinet after each exposure.

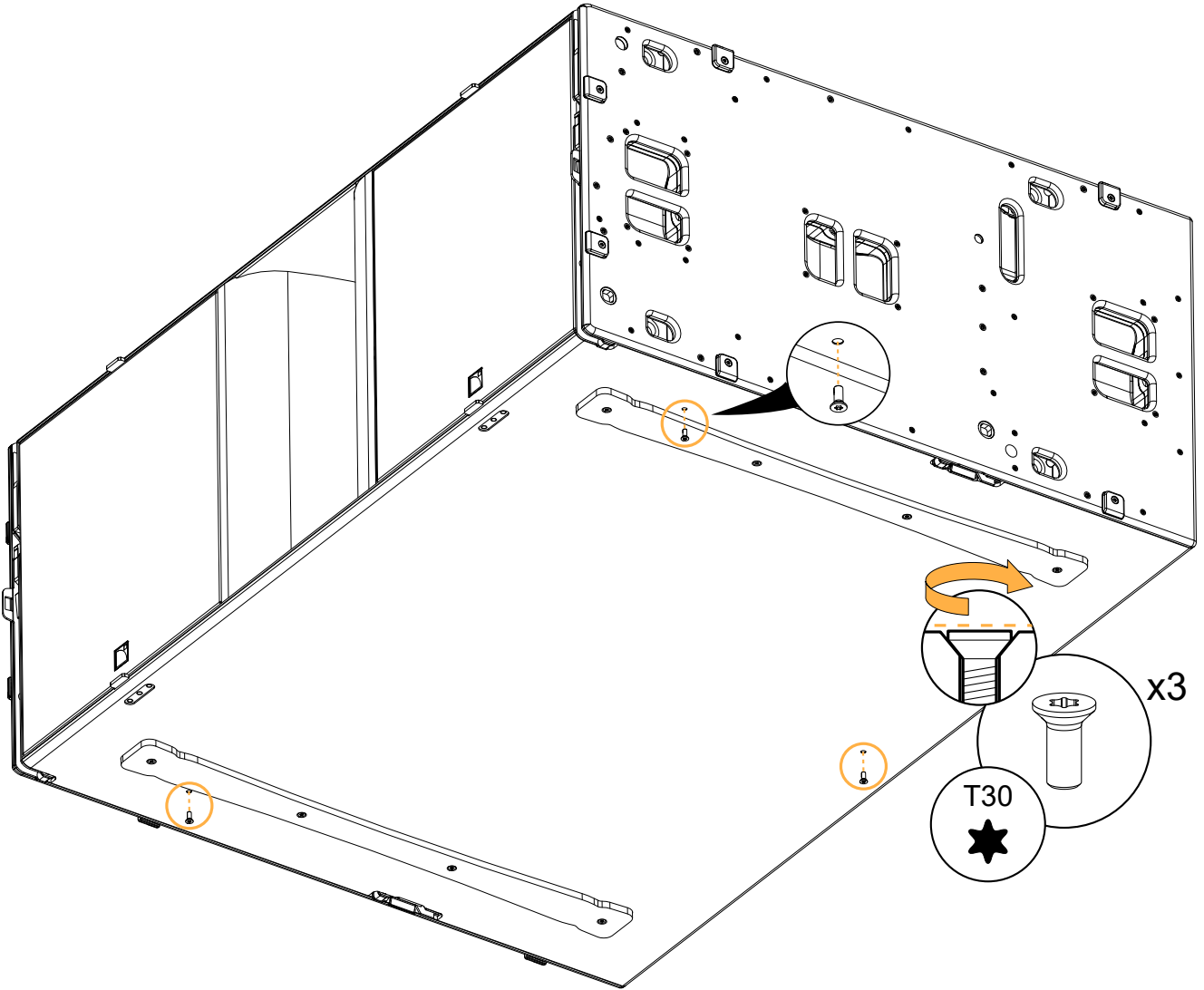

## Rigging elements

### L1-BUMP

L1-BUMP is a rigging frame designed for flying L1(D) and CS1.

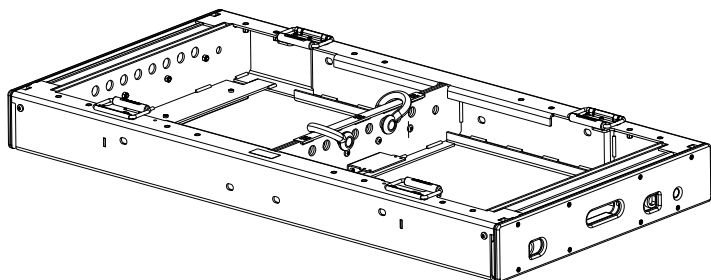

L1-BUMP can be used as the main lifting accessory for flying arrays of L1(D) and CS1, using the two included  $\text{\O}22$  mm shackles WLL 4.75 t.

**⚠ Risk of crushing injury**  
In a mixed CS1/L1(D) array, always position CS1 at the top.

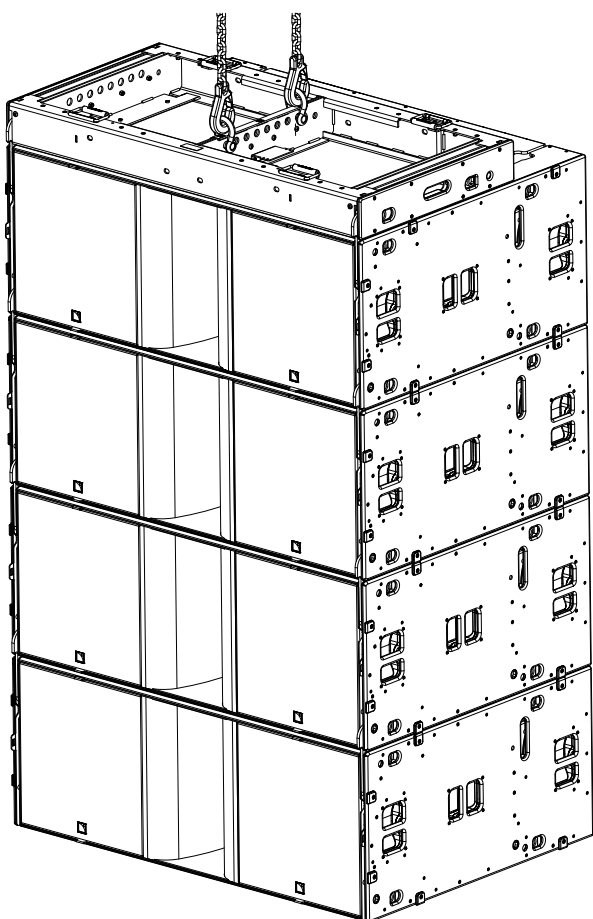

CS1 array

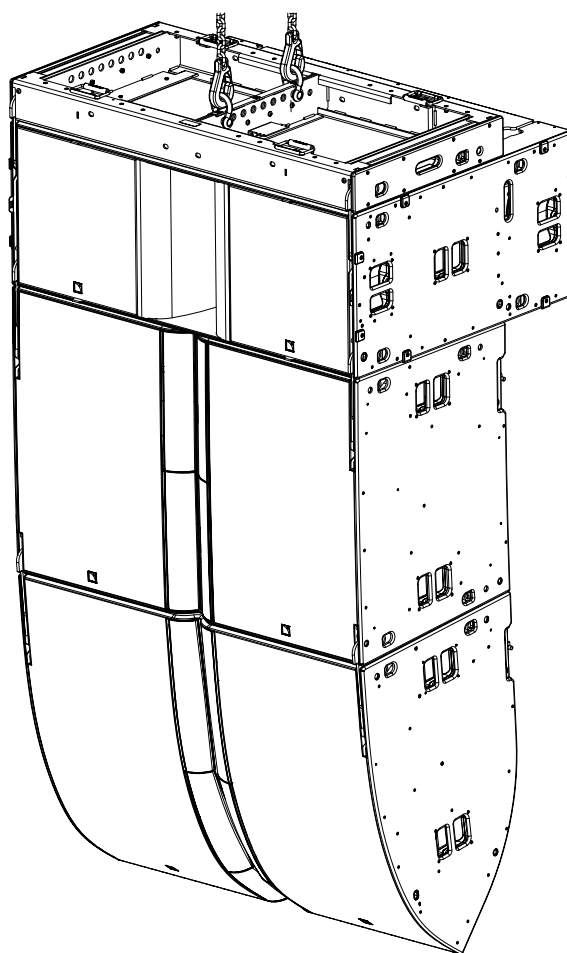

Mixed CS1/L1(D) array

L1-BUMP has a plate and openings for the use of a laser inclinometer.

Refer to [APPENDIX: Installing a laser inclinometer](#) (p.104).

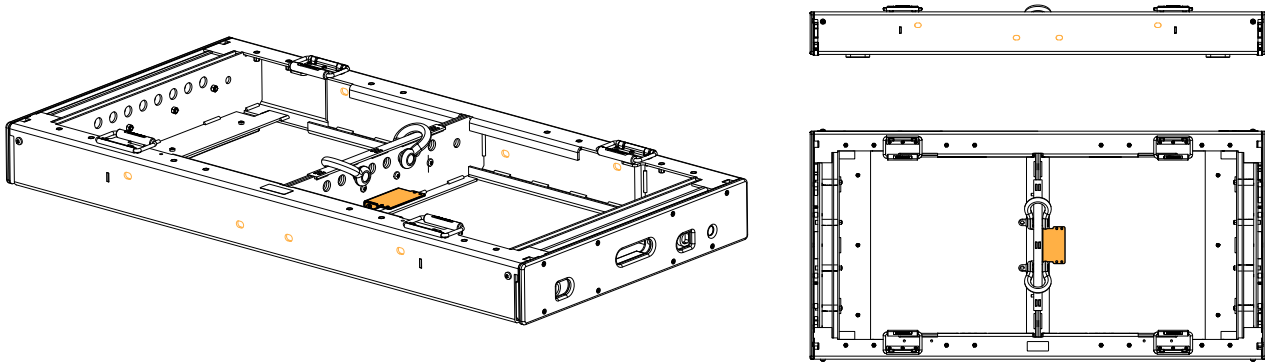

L1-BUMP is equipped with four spring-loaded lock systems to match the rigging arms of L1(D) and CS1.

The rigging elements are fitted with yellow safety labels that are visible when they are not safely locked.

**i** Slide to unlock the spring-loaded lock.

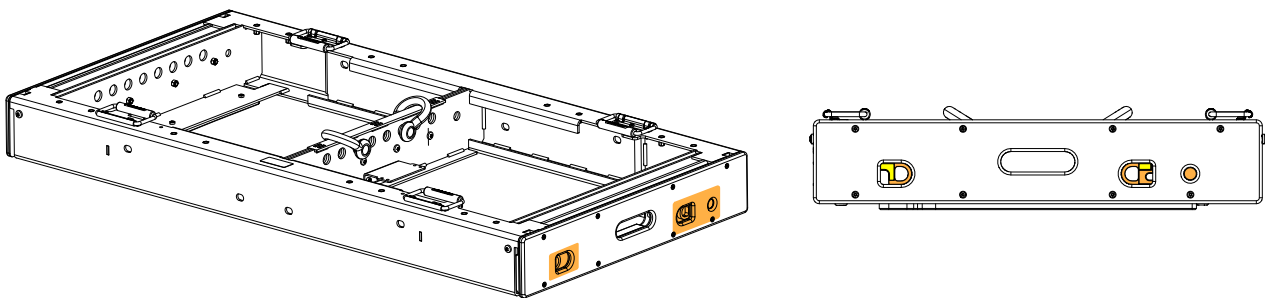

The central and side bars of L1-BUMP have eight holes each, for site angle adjustments.

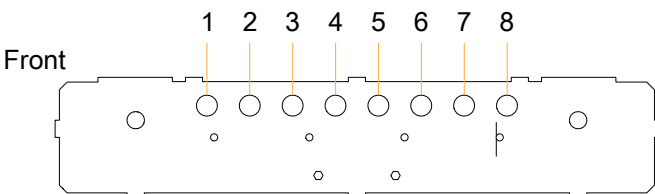

To increase the site angle, two additional holes are available for adding one [L1-BAR](#) (p.22) on the central bar or [CS1-BAR](#) (p.26) on each side.

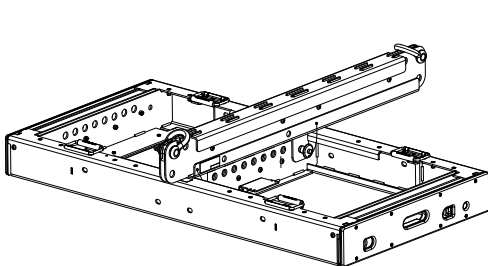

With one L1-BAR

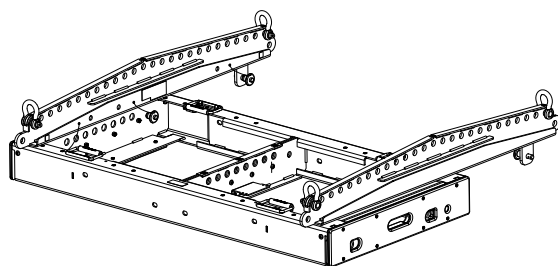

With two CS1-BAR

BPCHAIN 3.15T is an extension chain provided with L1-BUMP for climbing-hoist setup. Use the extension chain to prevent the chain bag from lying in front of the enclosures that are located at the top of the array.

The extension chain has a WLL (Working Load Limit) of 3.15 t.

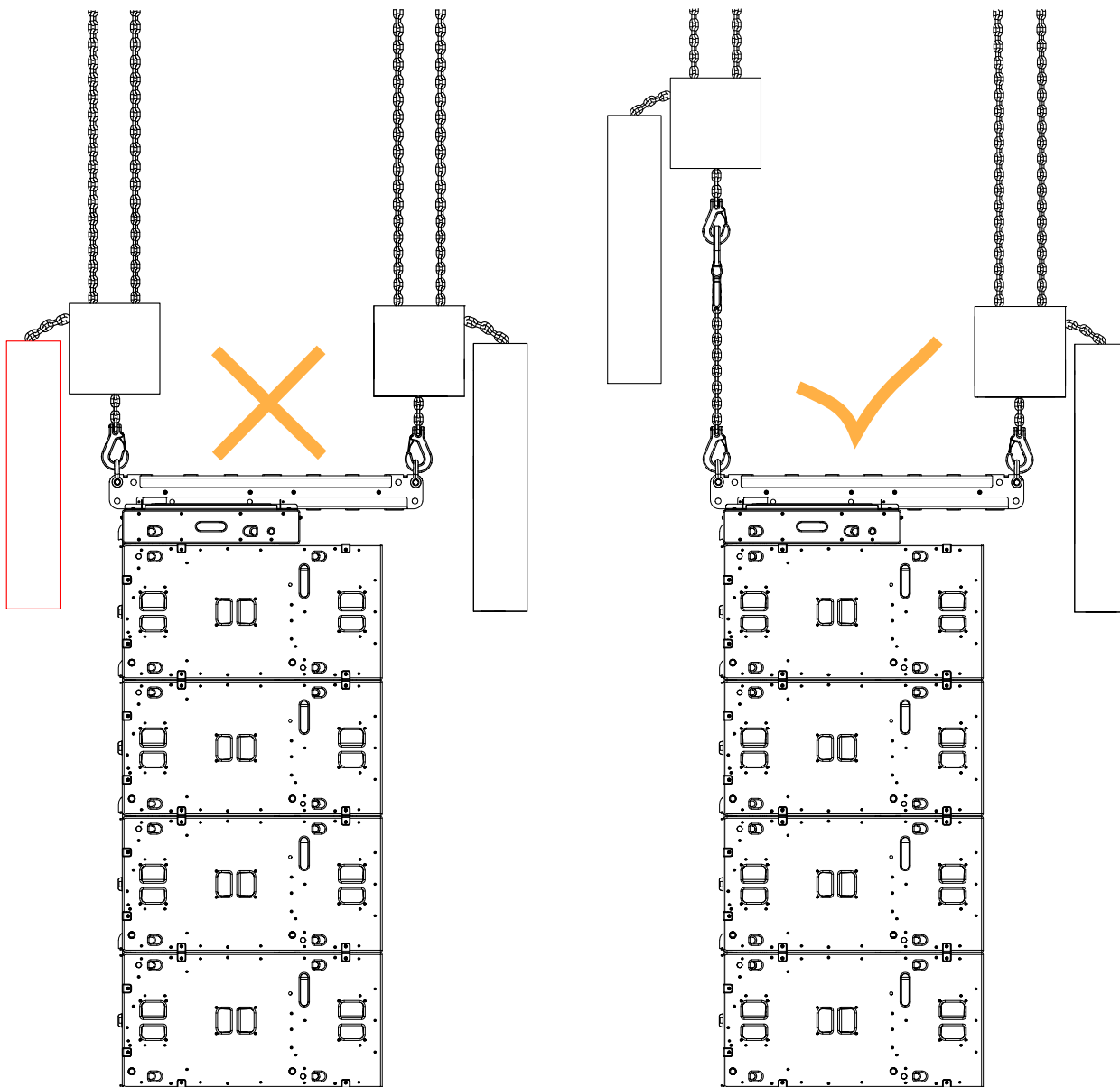

Without the adjustable extension chain

With the adjustable extension chain

L1-BUMP is provided with L1CS1-RAKMOUNT to secure up to four LA-RAK III above the array.

Refer to [L1CS1-RAKMOUNT](#) (p.27).

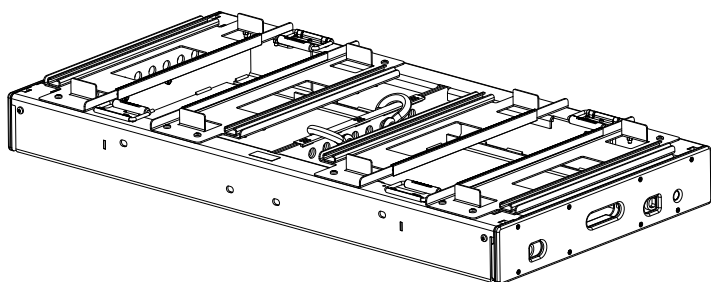

## L1-BAR

L1-BAR is an extension bar designed to extend the site angle capability of L1(D)/CS1 arrays.

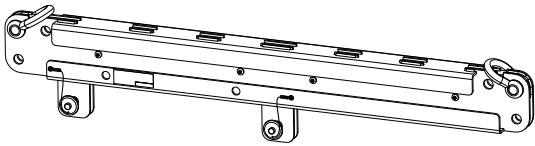

Four pickup points are available on L1-BAR, compatible with Ø22 mm shackles WLL 4.75 t (two provided). An extra hole is available on each side of L1-BAR for cable pick. Always implement a secondary safety using available holes.

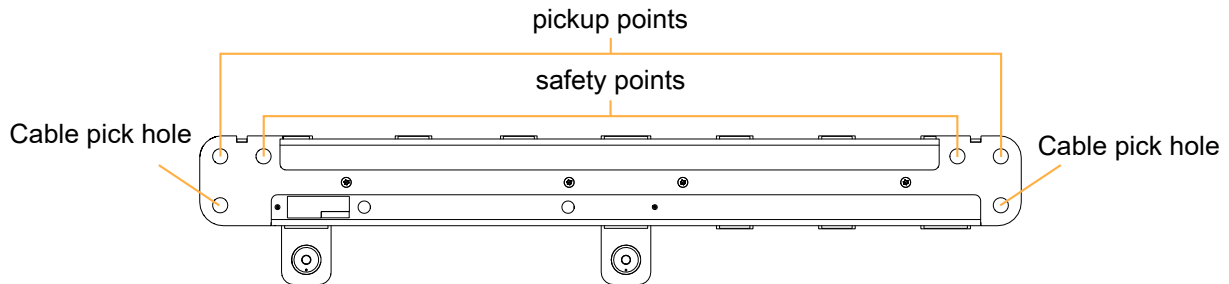

L1-BAR attaches to L1-BUMP as a rear or front extension, offering 8 pickup points positions. The rear extension is suited to downwards site angles. The front extension is suited to upwards site angles.

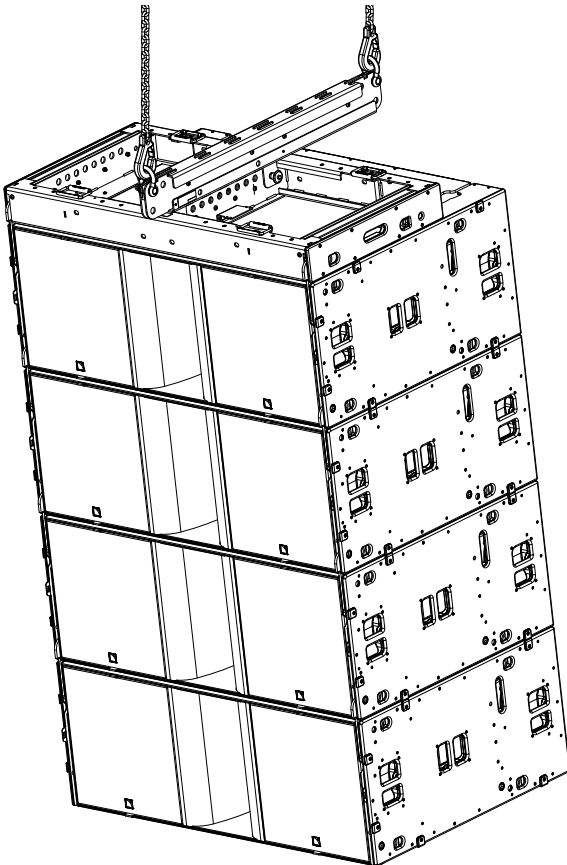

L1-BAR as a rear extension

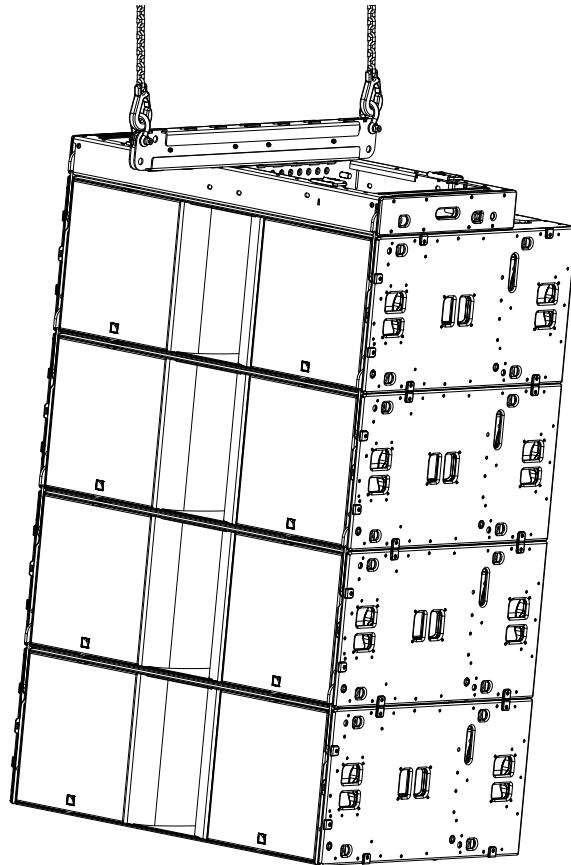

L1-BAR as a front extension

Two additional holes are available to store the two ball-locking pins.

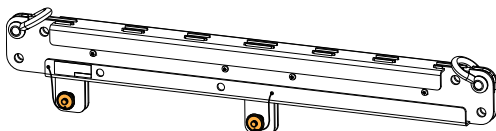

rigging position

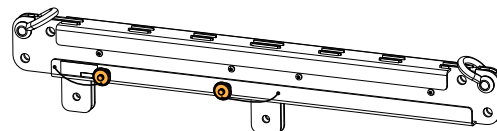

storage position

## CS1-BUMP

CS1-BUMP is a rigging frame designed for flying smaller L1(D) arrays and CS1 arrays.

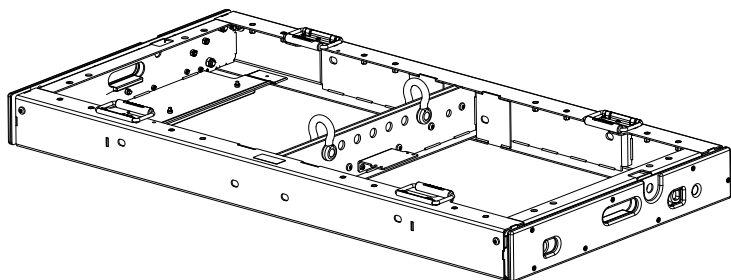

CS1-BUMP can be used as the main lifting accessory for flying arrays of L1(D) and CS1, using the four included  $\varnothing 19$  mm shackles WLL 3.25 t and the extension chain.



### Risk of crushing injury

In a mixed CS1/L1(D) array, always position CS1 at the top.

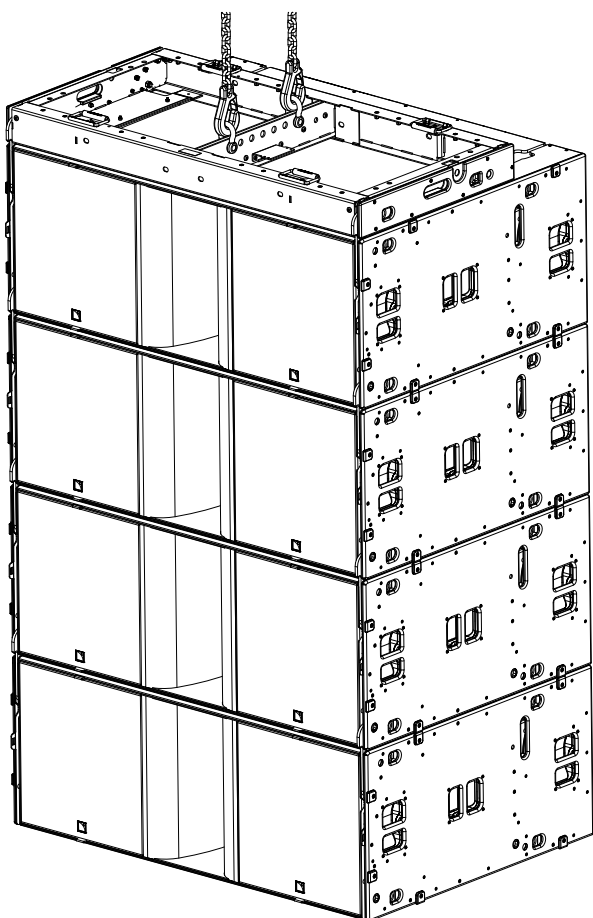

CS1 array

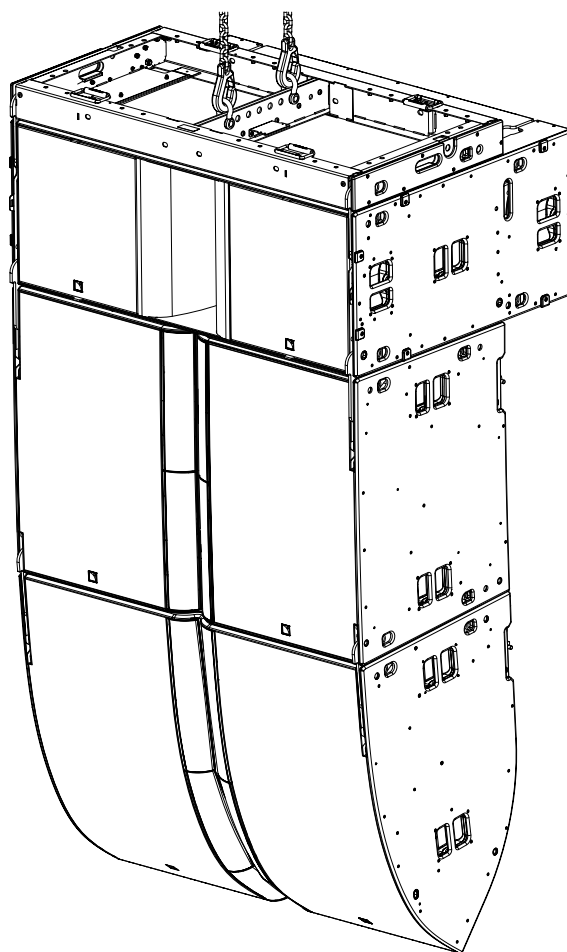

Mixed CS1/L1(D) array

CS1-BUMP features a plate and openings for the use of a laser inclinometer.

Refer to [APPENDIX: Installing a laser inclinometer](#) (p.104).

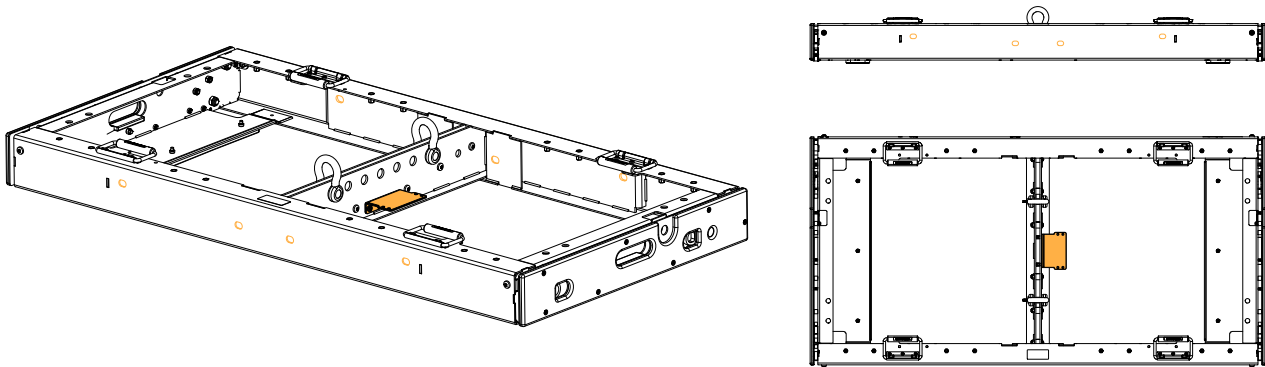

CS1-BUMP is equipped with four spring-loaded lock systems to match the rigging arms of L1(D) and CS1. The rigging elements are fitted with yellow safety labels that are visible when they are not safely locked.

**i** Slide to unlock the spring-loaded lock.

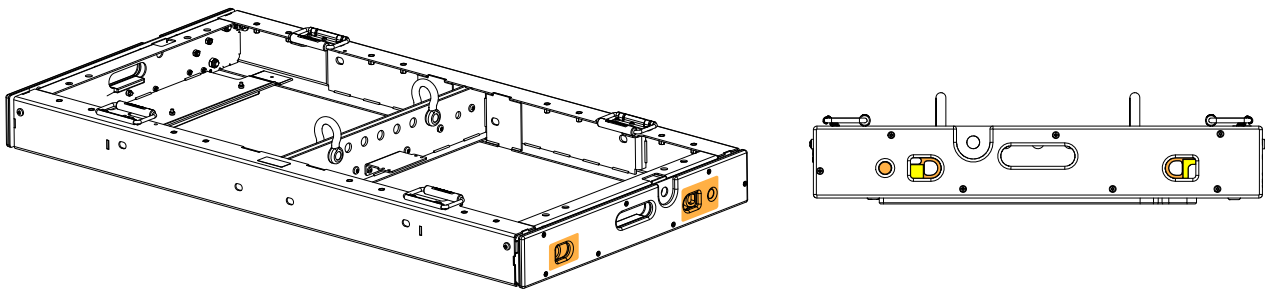

The central bar of CS1-BUMP has seven holes for site angle adjustments.

One hole is available on each side and can be used to secure CS1-BUMP to two motors using Ø19 mm shackles WLL 3.25 t.

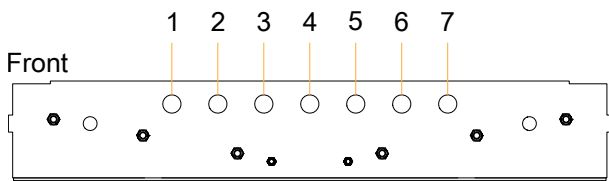

CS1-BUMP central bar

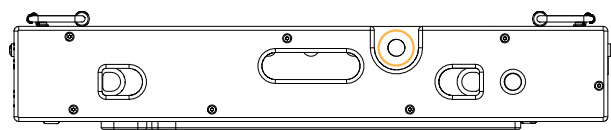

CS1-BUMP side view

BPCHAIN 3.15T is an extension chain provided with CS1-BUMP for climbing-hoist setup. Use the extension chain to prevent the chain bag from lying in front of the enclosures that are located at the top of the array.

The extension chain has a WLL (Working Load Limit) of 3.15 t.

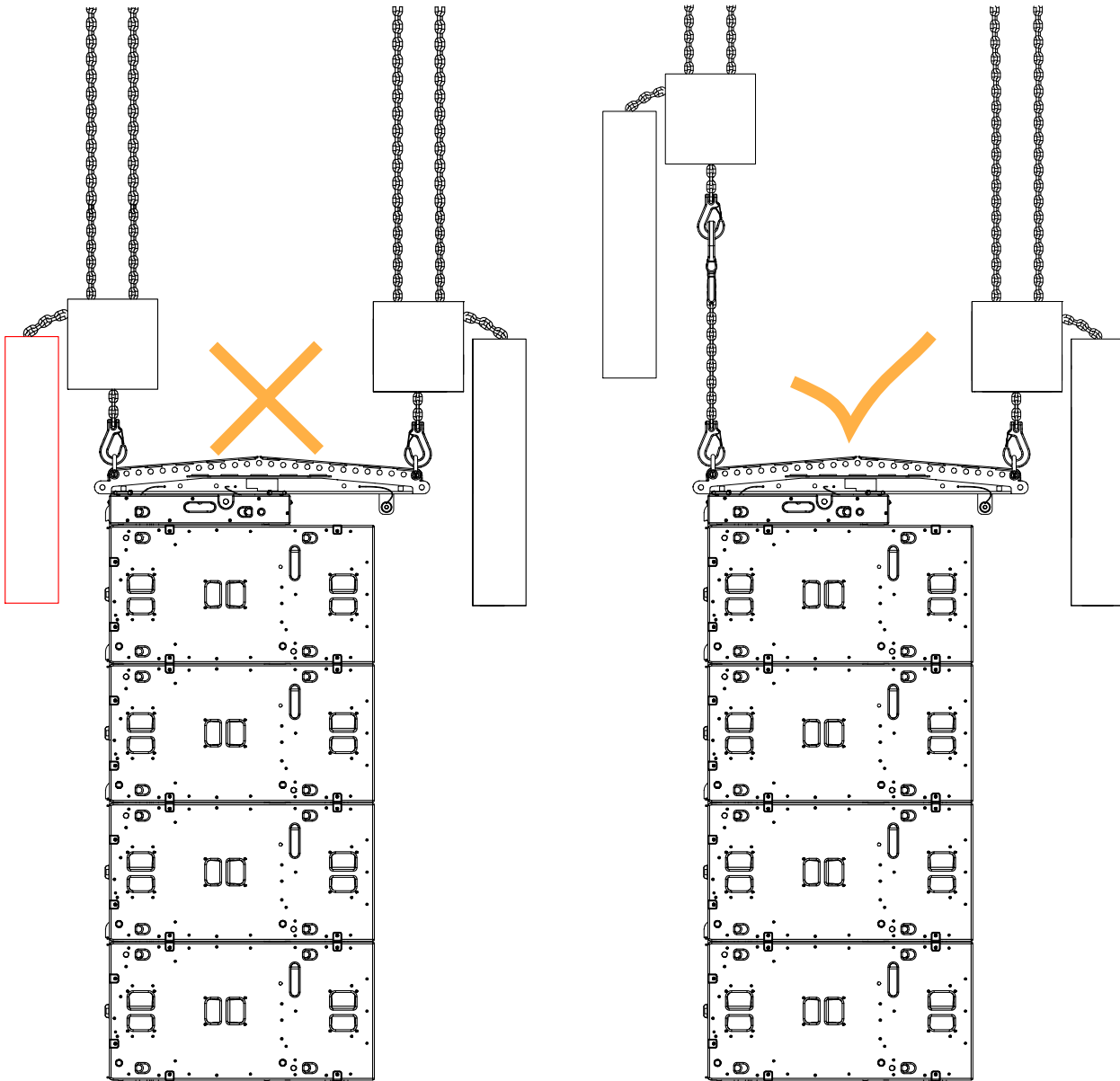

Without the adjustable extension chain

With the adjustable extension chain

CS1-BUMP is also compatible with L1CS1-RAKMOUNT to secure two LA-RAK III above the array.

Refer to [L1CS1-RAKMOUNT](#) (p.27).

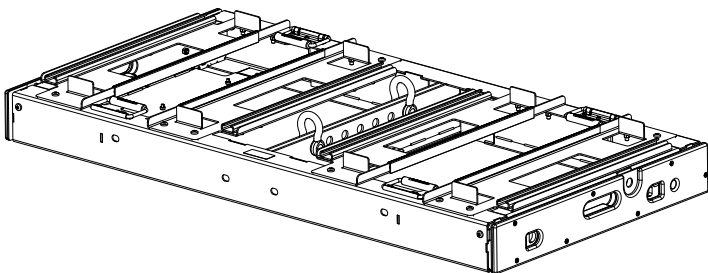

## CS1-BAR

CS1-BAR is an extension bar designed to extend the site angle capability of L1(D)/CS1 arrays.

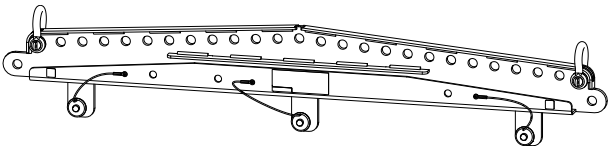

Twenty-six pickup points are available on CS1-BAR, compatible with Ø19 mm shackles WLL 3.25 t (two provided). CS1-BAR attaches to CS1-BUMP or L1-BUMP as a rear or front extension, in orientation A or B, offering 104 pickup points.

The labels "A" and "B" identify each orientation. The label toward the front indicate the orientation. Rotate CS1-BAR to switch orientation.

An extra hole is available on each side of CS1-BAR for cable pick.

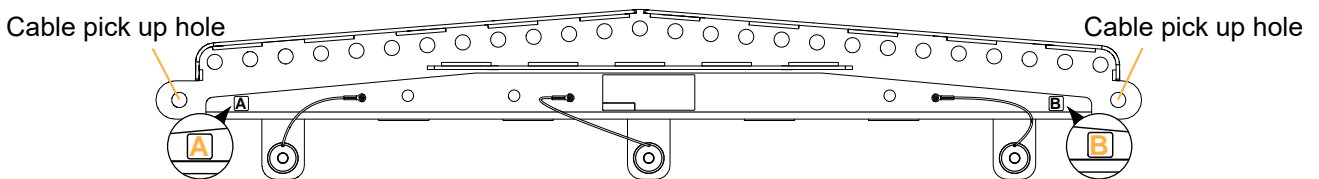

The rear extension is suited to downwards site angles. The front extension is suited to upwards site angles.

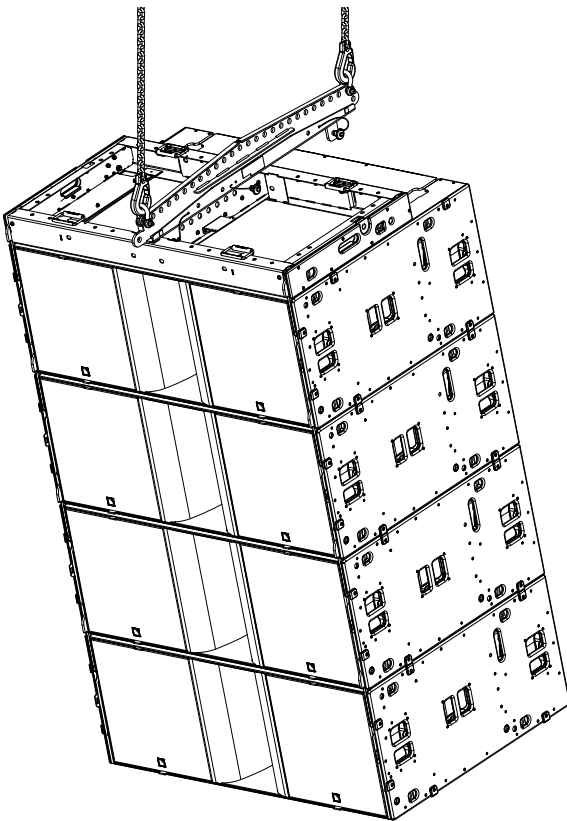

CS1-BAR as a rear extension

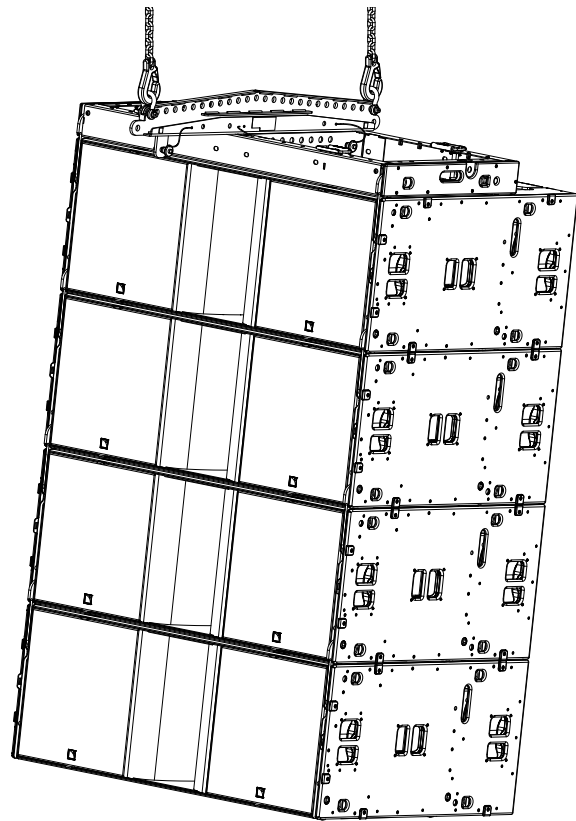

CS1-BAR as a front extension

Three additional holes are available to store the three ball-locking pins.

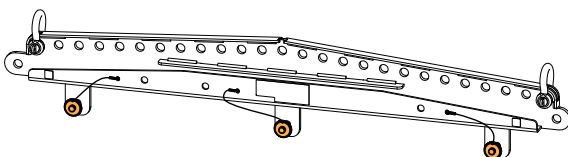

rigging position

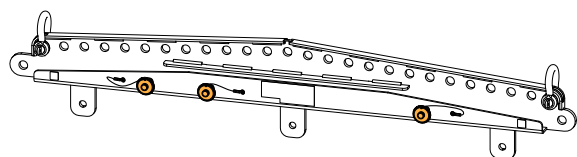

storage position

## L1CS1-RAKMOUNT

L1CS1-RAKMOUNT is designed to stack up to four LA-RAK III/LA-RAK II AVB on top of a flown array.

### ! Mechanical safety

A maximum of four racks can be stacked on top of L1-BUMP.

A maximum of two racks can be stacked on top of CS1-BUMP.

L1CS1-RAKMOUNT is composed of four mounting cradles with rails. The four cradles are screwed on the rigging frame.

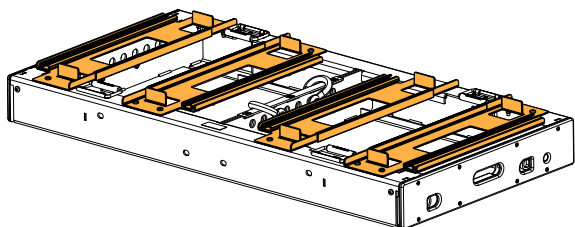

Using L1-BUMP

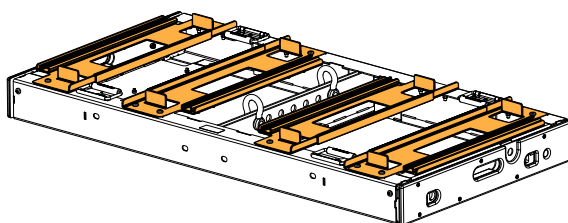

Using CS1-BUMP

### ! L1CS1-RAKMOUNT must be used with one extension bar.

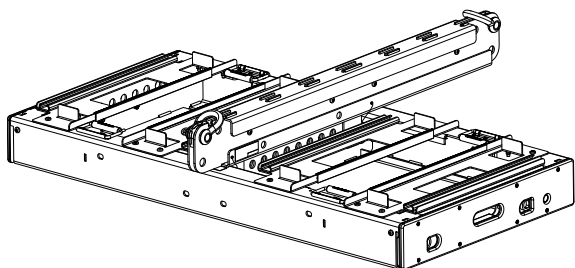

Using L1-BAR

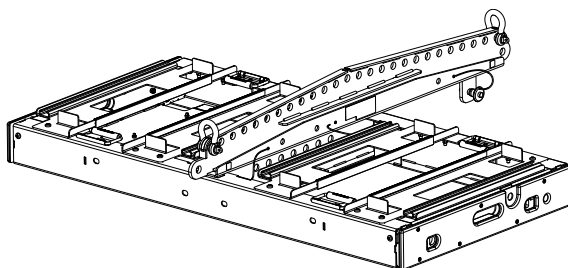

Using CS1-BAR

L1CS1-RAKMOUNT features a rack stabilizer to secure and balance the racks above the array.

The rack stabilizer is secured with a snap hook and a tether.

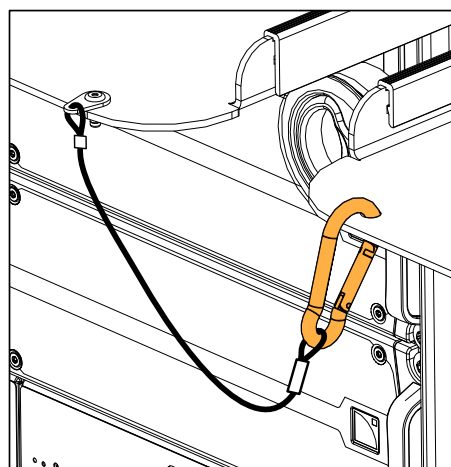
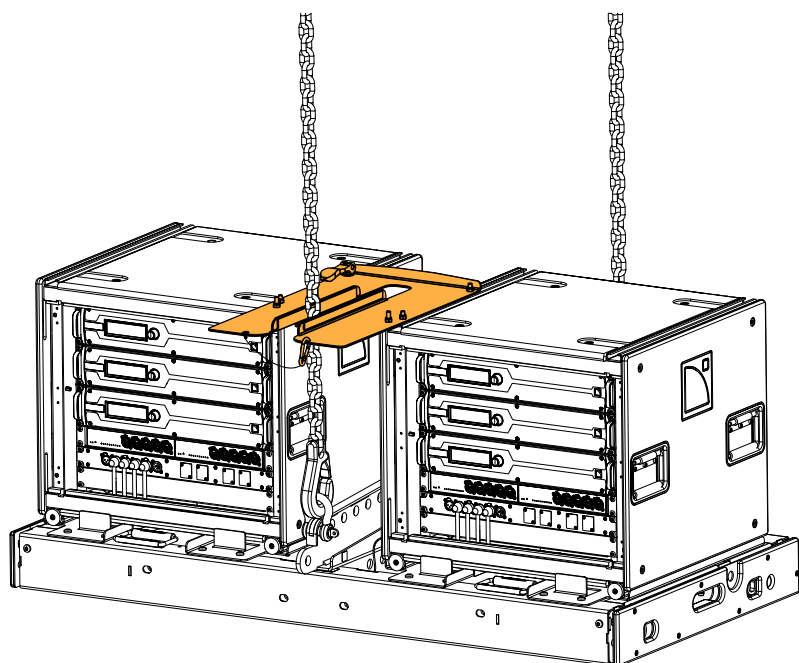

## CLAMP1000

CLAMP1000 is a rotary clamp designed to hang an enclosure array from a truss and control the azimuth angle.

CLAMP1000 is a set composed of CLAMP1000-BASE, a CLAMP1000 rotary base certified for 1000 kg / 2205 lb, with a choice of two mounting adaptors:

- CLAMP1000-SINGLE: a single point mounting adaptor for CLAMP1000-BASE.
- CLAMP1000-DUAL: a dual point mounting adaptor for CLAMP1000-BASE.

CLAMP1000-BASE is secured to the rigging accessory with a ball-locking mechanism.

CLAMP1000 is compatible with L1-BUMP, CS1-BUMP, and CS1-BAR.

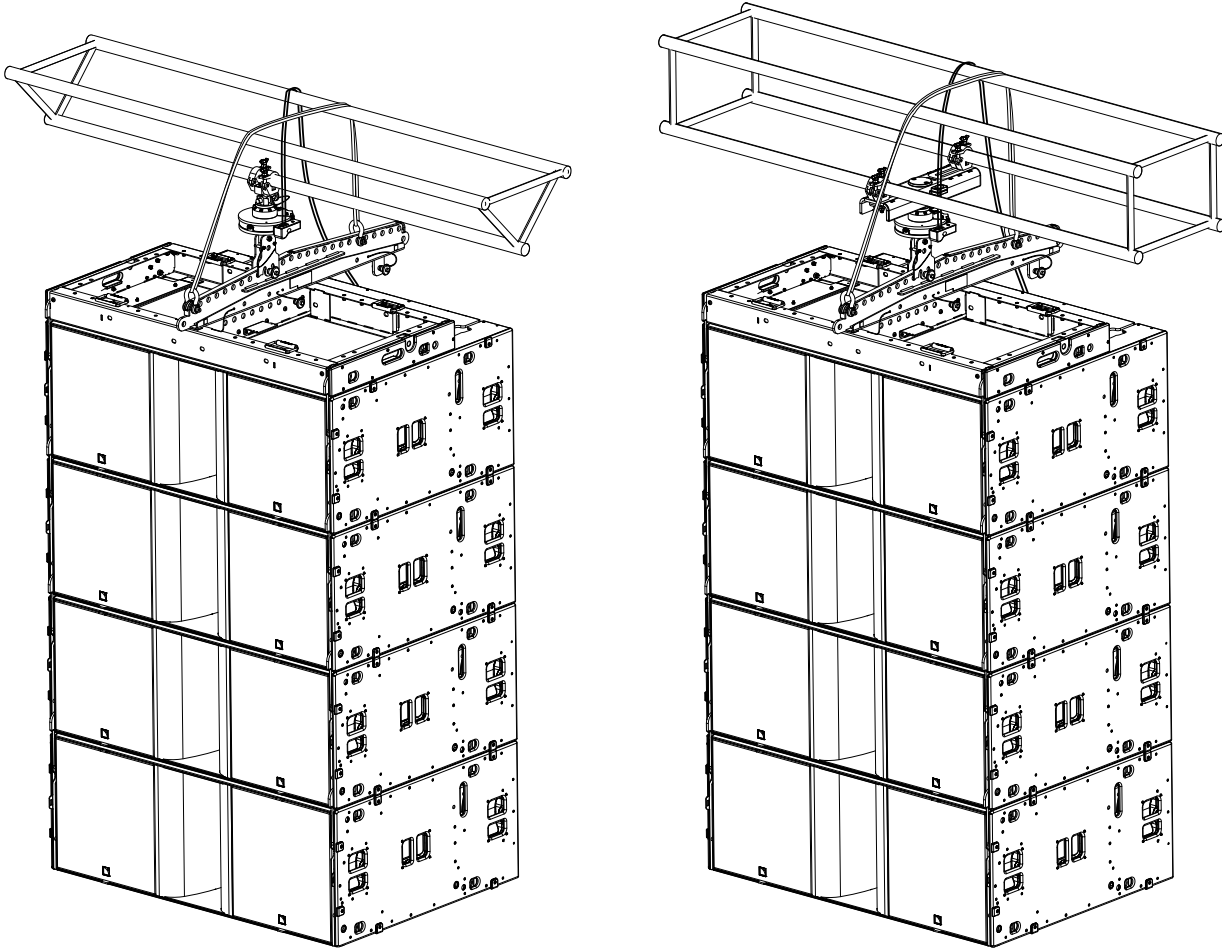

With CLAMP1000-SINGLE

With CLAMP1000-DUAL

Refer to the **CLAMP1000 Owner's Manual** for product and mounting description.

## K1-DELTA

Combined with a rigging frame and an extension bar, K1-DELTA can be used to control the azimuth angle.

The recommended space between the two lifting points is 1 m / 3.3 ft.

By adjusting the height of both pickup points, it is possible to adjust the azimuth angle from  $-10^\circ$  to  $+10^\circ$ .

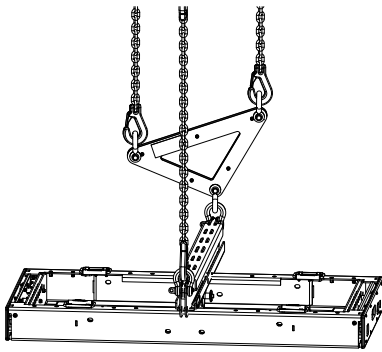

+10°

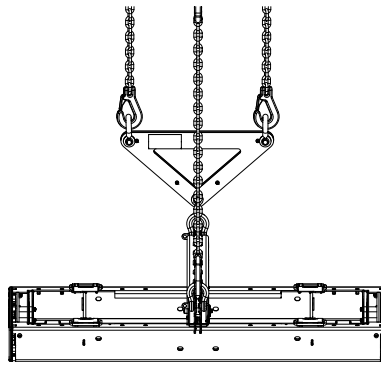

0°

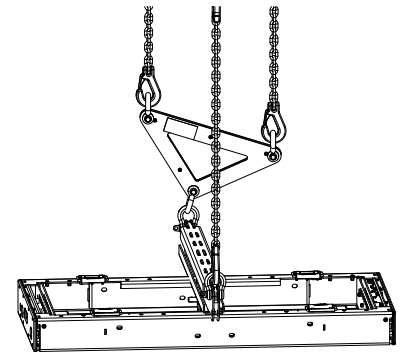

-10°

K1-DELTA is equipped with three  $\varnothing 22$  mm shackles WLL 4.75 t.

## Storage and handling

### CS1-PLA

CS1-PLA is a dolly board designed to be fitted to the front of a CS1 with two spring-loaded pins.



**CS1-PLA is intended for use only with L-Acoustics CS1.**

Use with other equipment may result in instability causing injury.



**Risk of injury**

A minimum of two operators is required to tip CS1 over and put CS1-PLA on its wheels.

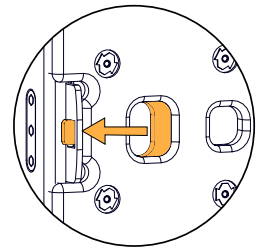
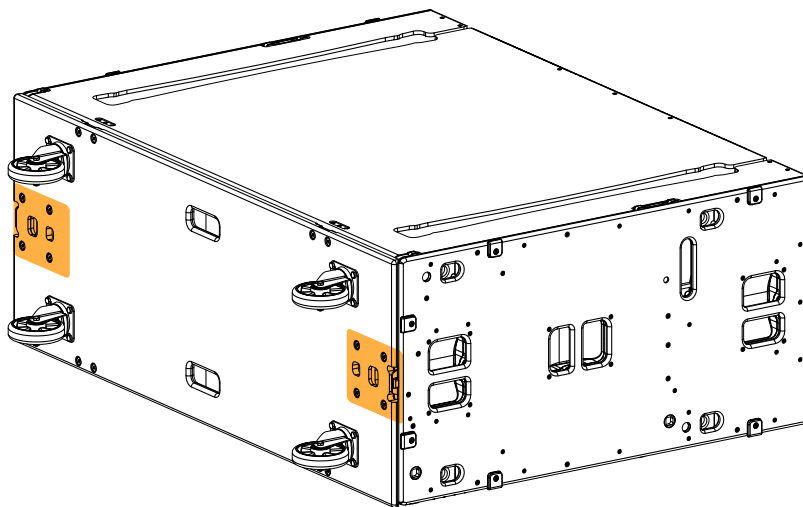
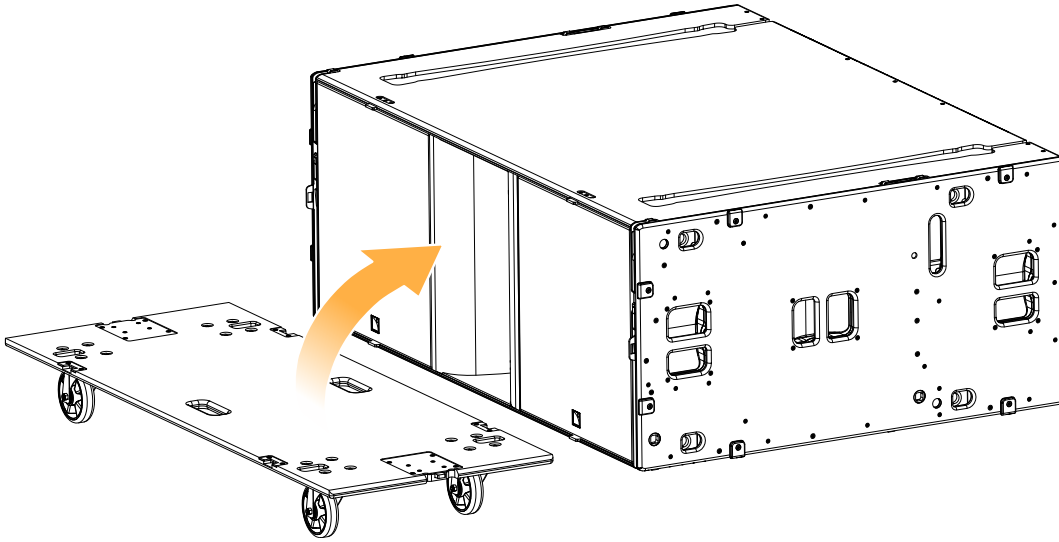

Multiple CS1-PLA can be stacked for storage.

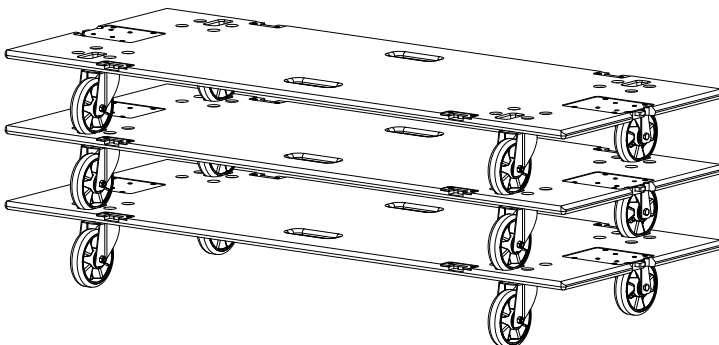

## CS1-COV

CS1-COV is an individual protective cover for one CS1 on CS1-PLA.

CS1-COV has:

- two foldable flaps at the top with a velcro fastener to give access to CS1 connector plate for identification.
- zippers at each corner, allowing access to the top or bottom of the enclosure.

CS1-COV features a reinforcing plate that protects the rear grills of the enclosure and helps maintain the cover in place. Fold CS1-COV and use the reinforcing plate straps to secure the cover.

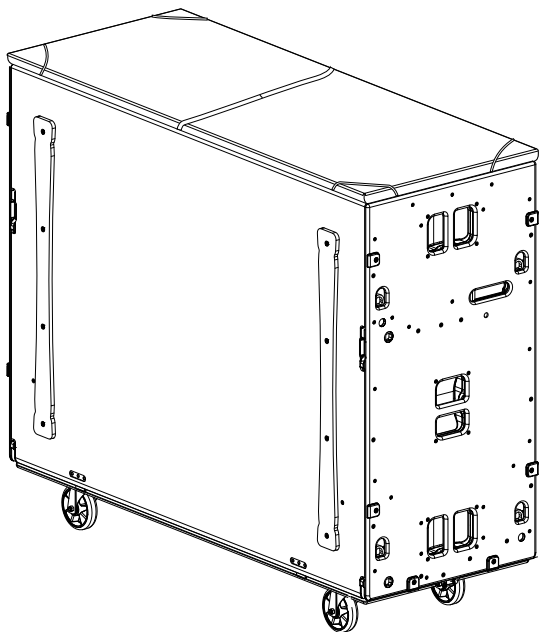

CS1 with CS1-COV folded and secured with reinforcing plate straps

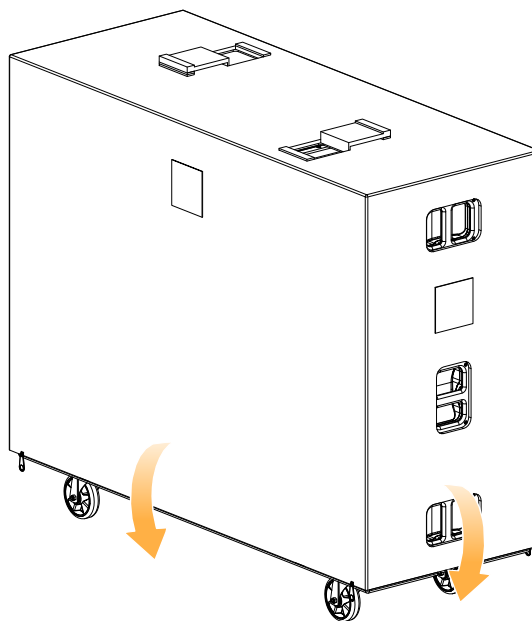

CS1 with CS1-COV unfolded

## CS1-CHARIOT

CS1-CHARIOT is a chariot designed to transport up to four CS1.

**!** **CS1-CHARIOT is intended for use only with L-Acoustics CS1.**  
Use with other equipment may result in instability causing injury.

**!** **Do not move or transport more than four CS1 on CS1-CHARIOT.**

CS1-CHARIOT features four locks to secure CS1: push to engage the latch and secure the enclosure, pull to disengage the latch.

**!** **Risk of product damage**  
Disengage all the latches before putting an enclosure on the chariot.

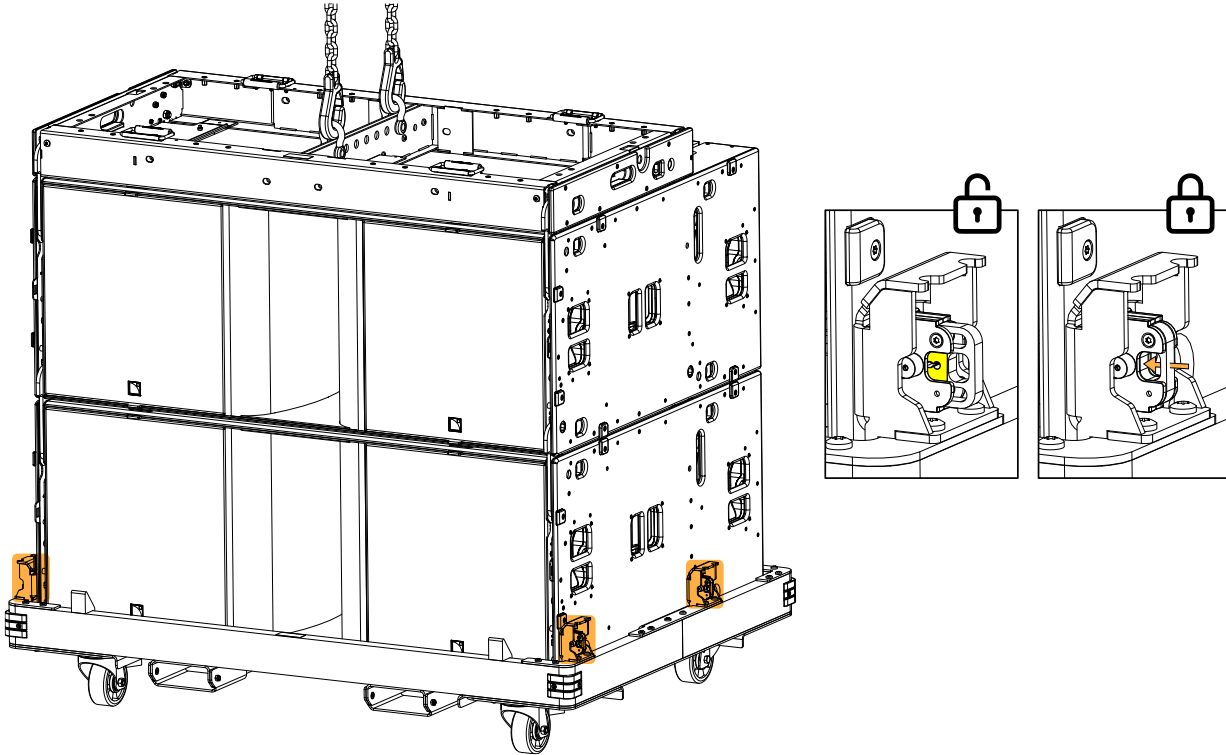

**!** **Risk of product damage and crushing injury**  
For proper support when using a forklift truck, ensure forks are long enough (min. 1200 mm / 47 in).  
Forks that are too short may cause the load to tip over.

Multiple CS1-CHARIOT can be stacked for storage.

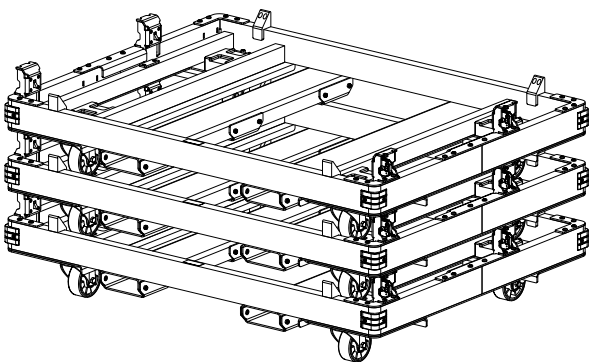

**!** **Risk of severe injury**  
Remove all enclosures before performing any maintenance operation on CS1-CHARIOT.

The height of a stack depends on the number of CS1 stacked on CS1-CHARIOT. For more information about the dimensions, see [CS1-CHARIOT specifications](#) (p.98).

## CS1-CHARIOTCOV

CS1-CHARIOTCOV is a protective cover for a stack of two to three CS1 on CS1-CHARIOT. To fit a stack of two CS1, CS1-CHARIOTCOV must be folded inwards and secured with the provided velcro straps.

Zippers at each corner of CS1-CHARIOTCOV provide access to the front or the rear side of the stack.

A pleat is available at the top of CS1-CHARIOTCOV, giving enough space to store a CS1-BUMP/L1-BUMP on top of the enclosure stack.

**!** Do not use CS1 with CS1-COV on, even with the front lifted.  
The fabric is not acoustically neutral and is not compatible with the LC loudspeakers.

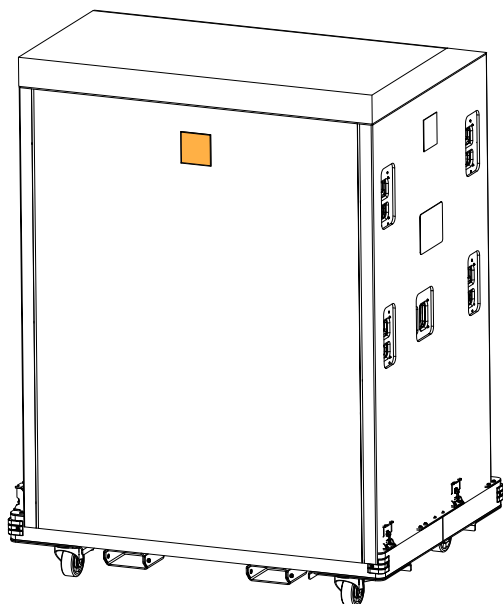

CS1-CHARIOTCOV front

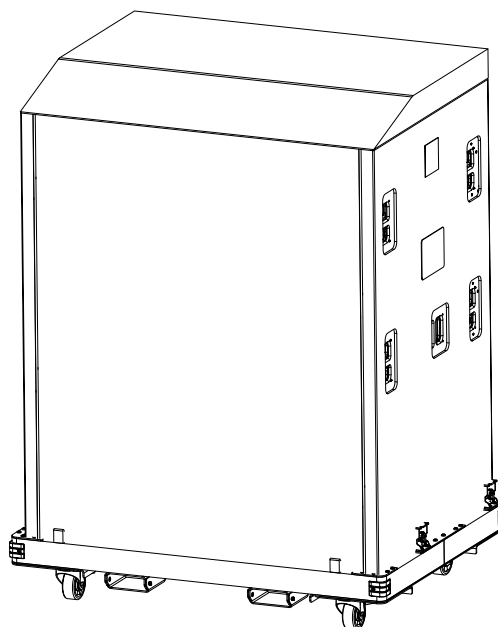

CS1-CHARIOTCOV rear

## L1CS1-BUMPFLIGHT

L1CS1-BUMPFLIGHT is a flightcase for transporting the accessories of the L1 system.

1. 1 or 2 L1-BAR / CS1-BAR
2. 1 L1-BUMP / CS1-BUMP
3. L1-LASERMOUNT
4. 1 or 2 L1-BAR / CS1-BAR
5. 1 L1-BUMP / CS1-BUMP
6. L1CS1-RAKMOUNT stabilizer
7. K1-DELTA
8. 1 L1-PULLBACK

It is possible to add the L1CS1-BUMPFLIGHTADDLAYER extension in order to store an additional L1-BUMP / CS1-BUMP, 2 L1-BAR / CS1-BAR, 1 L1-PULLBACK, and other smaller accessories.

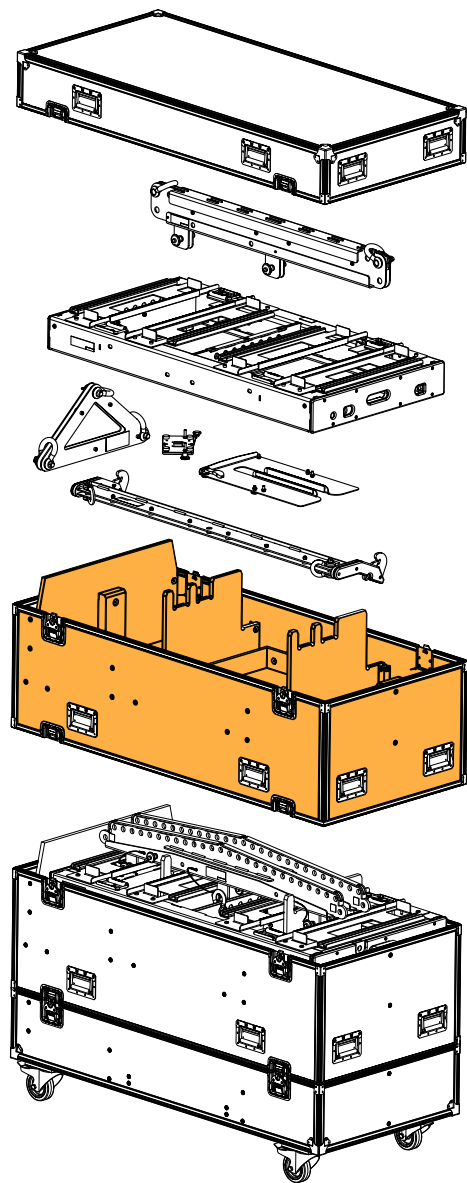
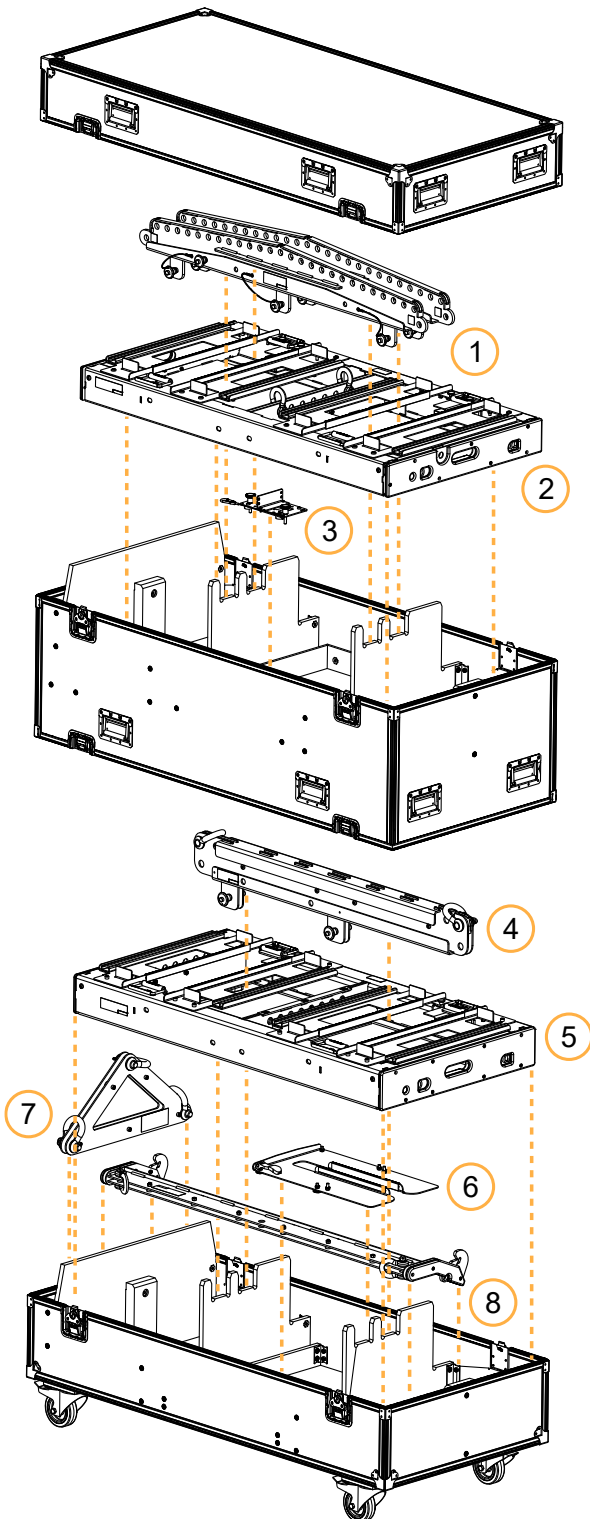

Refer to [L1CS1-BUMPFLIGHT specifications](#) (p.101) and [L1CS1-BUMPFLIGHTADDLAYER specifications](#) (p.102) for information about dimensions.

## Mechanical safety

### Flown configurations

The CS1 rigging system complies with 2006/42/EC: Machinery Directive. It has been designed following the guidelines of BGV-C1.

2006/42/EC: Machinery Directive specifies a safety factor of 4 against the rupture. The flown deployments described in this manual achieve a safety factor of **5 or more**.

Refer to Soundvision for the safety factor of a specific deployment.

The **maximum limit** gives the maximum number of elements for which the safety factor can be compliant with the 2006/42/EC: Machinery Directive, when the other deployment parameters provide the best mechanical conditions.

For mixed arrays refer to your Soundvision model.

### CS1

configuration	rigging accessory	maximum limit
flown	CS1-BUMP + CS1-BAR (optional)	8 CS1
	CS1-BUMP + L1CS1-RAKMOUNT + CS1-BAR	2 LA-RAK III + 8 CS1
	L1-BUMP + L1-BAR (optional)	16 CS1
	L1-BUMP + 2 CS1-BAR (optional)	12 CS1
	L1-BUMP + L1CS1-RAKMOUNT + L1-BAR	4 LA-RAK III + 14 CS1

### Other configurations

For other configurations, respect the recommended maximum limit for optimal stability.

### CS1

configuration	rigging accessory	maximum limit
ground-stacked	No rigging accessory	4
stacked on chariot	CS1-CHARIOT	4

## Assessing mechanical safety

---

-  **Mechanical safety of the rigging system**  
 Before any installation, always model the system in Soundvision and check the **Mechanics view** section for any stress or stability warning.

In order to assess the actual safety of any array configuration before implementation, refer to the following warnings:

-  **Rated working load limit (WLL) is not enough**  
 The rated WLL is an indication of the element resistance to tensile stress. For complex mechanical systems such as loudspeaker arrays, WLLs cannot be used per se to determine the maximum number of enclosures within an array or to assess the safety of a specific array configuration.

### **Mechanical modeling with Soundvision**

The working load applied to each linking point, along with the corresponding safety factor, will depend on numerous variables linked to the composition of the array (type and number of enclosures, splay angles) and the implementation of the flying or stacking structure (number and location of flying points, site angle). This cannot be determined without the complex mechanical modeling and calculation offered by Soundvision.

### **Assessing the safety with Soundvision**

The overall safety factor of a specific mechanical configuration always corresponds to the lowest safety factor among all the linking points. Always model the system configuration with the Soundvision software and check the **Mechanics view** section to identify the weakest link and its corresponding working load. By default, a stress warning will appear when the mechanical safety goes beyond the recommended safety level.

### **Safety of ground-stacked arrays in Soundvision**

For ground-stacked arrays, a distinct stability warning is implemented in Soundvision. It indicates a tipping hazard when the array is not secured to the ground, stage or platform. It is the user's responsibility to secure the array and to ignore the warning.

### **Additional safety for flown arrays**

When flying an array, use available holes to implement a secondary safety.

### **Considerations must be given to unusual conditions**

Soundvision calculations are based on usual environmental conditions. A higher safety factor is recommended with factors such as extreme high or low temperatures, strong wind, prolonged exposition to salt water, etc. Always consult a rigging specialist to adopt safety practices adapted to such a situation.

## Loudspeaker configurations

CS1 is a cardioid enclosure featuring two cardioid subwoofer loudspeakers (SC) on the sides, allowing a standard array to exhibit a broadband cardioid pattern that minimizes rear SPL at low frequencies.

A CS1 system can be deployed to extend the bandwidth of the main system in the low-end or increase sub-low resources.

Two LF polar patterns are available: a cardioid pattern (preset [CS1\_xx]) or a supercardioid pattern (preset [CS1\_xx\_S]). Use the same LF polar pattern for the entire system. Refer to [Polar pattern](#) (p.13).

There are two distinct applications for CS1:

- As a subwoofer for increased impact, using the [CS1\_60] / [CS1\_60\_S] preset.
- As an LF extension in a line source for enhanced throw, using [CS1\_X] / [CS1\_X\_S] preset with L1(D).

CS1 can be driven by the LA7.16(i) and LA12X amplified controllers.

### CS1 as a subwoofer, using the [CS1\_60] / [CS1\_60\_S] preset

The [CS1\_60] / [CS1\_60\_S] factory preset provides the subwoofer system with an upper frequency limit at 60 Hz in order to optimize the acoustic coupling with a main full-range system.

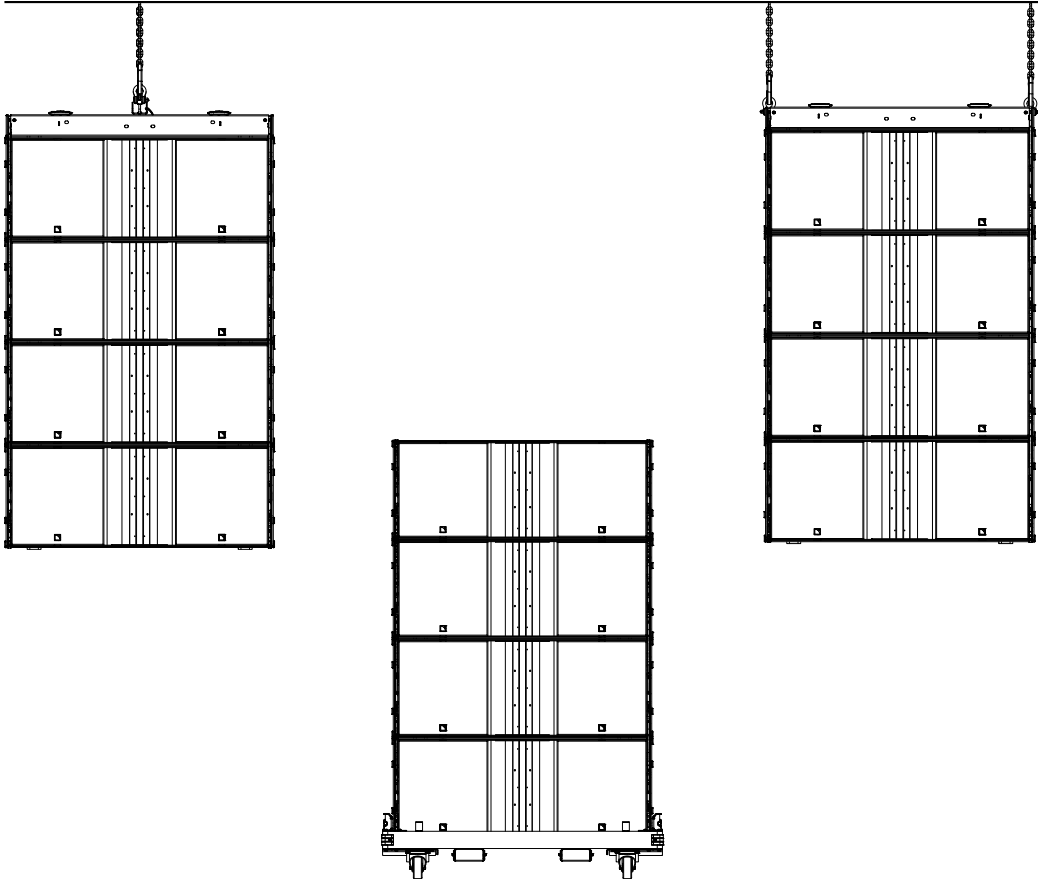

Preset	[CS1_60] [CS1_60_S]
Low frequency limit (-10 dB)	25 Hz

#### **!** Delay values

When combining a line source with subwoofers, delays may have to be added to the presets. Refer to the Preset Guide to obtain the pre-alignment delay values.

#### **i** Minimum distance from the wall

CS1 configurations require a minimum distance of 1 m / 3 ft from the wall. Below this distance, rear rejection performance can be degraded.

#### **i** Minimum distance between two stacks of CS1

CS1 configurations require a minimum distance of 1.5 m / 5 ft between stacks. Below this distance, rear rejection performance can be degraded.

### CS1 as an LF extension in an L1(D) line source, using the [CS1\_X] / [CS1\_X\_S] preset

By providing CS1 with the same frequency response as the L1(D) low section, the [CS1\_X] / [CS1\_X\_S] preset allows the CS1 enclosure to be used as an LF line source element, increasing the length of the sub-low line source.

## Rigging procedures

### Preparing CS1-BUMP for rigging

<b>Rigging accessories</b>	CS1-BUMP CS1-BAR K1-DELTA (optional) BPCHAIN 3.15T (optional) 2 × Ø19 mm shackles WLL 3.25 t
<b>Min number of operators</b>	2



To avoid any physical handling, CS1-BUMP must be transported and prepared in L1CS1-BUMPFLIGHT.



Check the sticker at the front of CS1-BUMP to identify the sides.

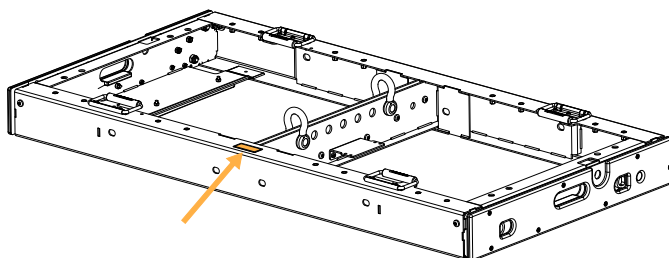

Follow the same procedure for L1-BUMP and L1-BAR.

#### Procedure

1. Place L1CS1-BUMPFLIGHT at the rigging location.
2. Remove the lid and any compartment to access CS1-BUMP.

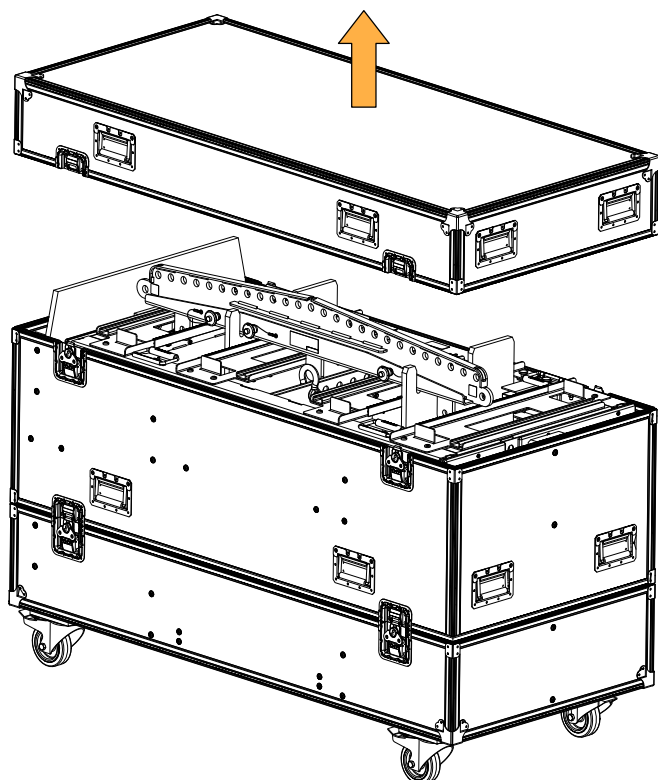

3. Lift CS1-BAR using the motors.

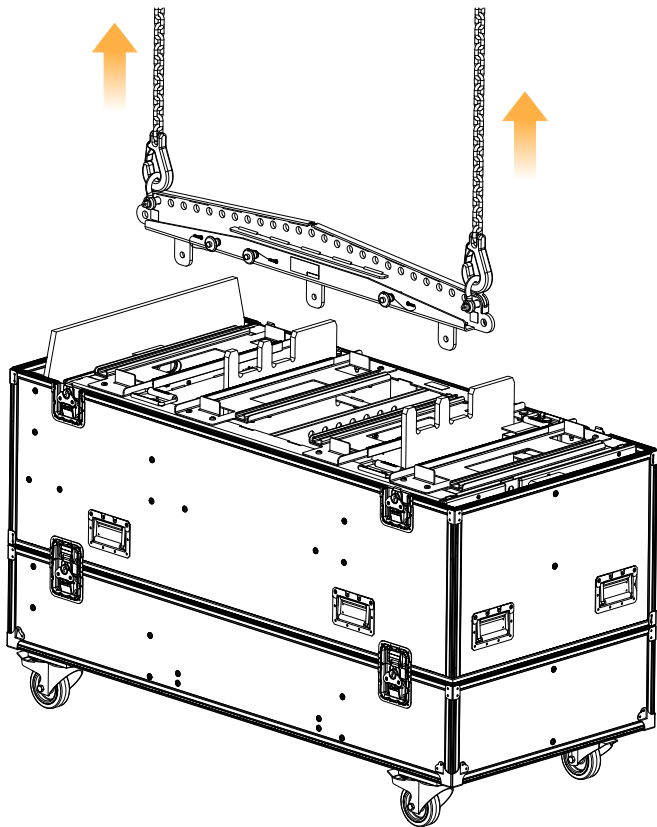

4. Rotate L1CS1-BUMPFLIGHT and align CS1-BUMP holes with CS1-BAR holes.



The extension bars can be attached as a rear or a front extension.  
CS1-BAR can be attached in position A or B. See [CS1-BAR](#) (p.26)

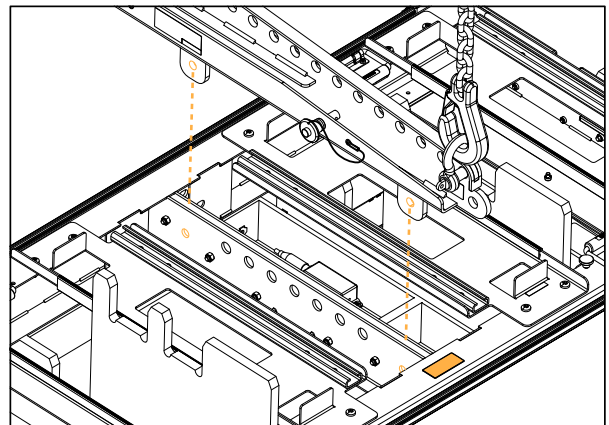
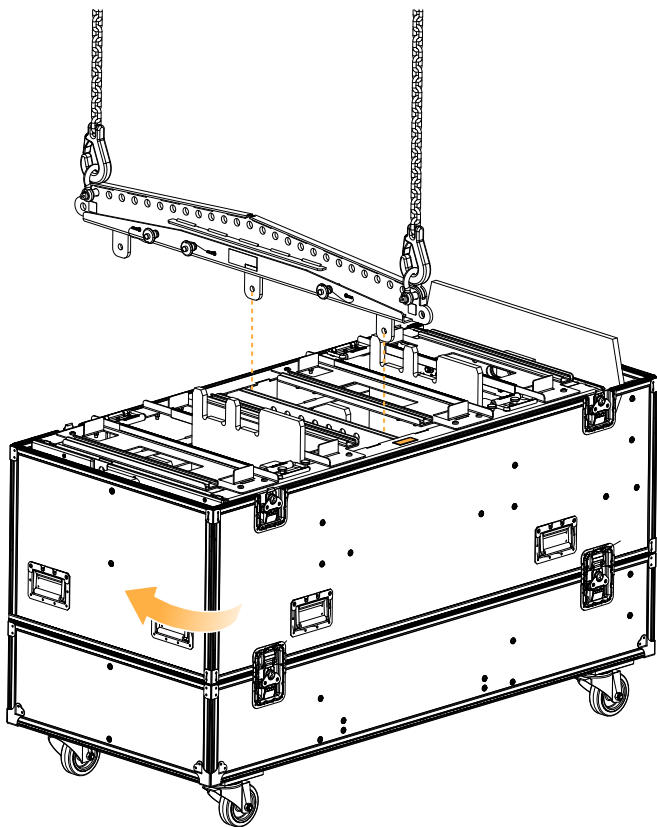

5. Lower and position CS1-BAR on CS1-BUMP.

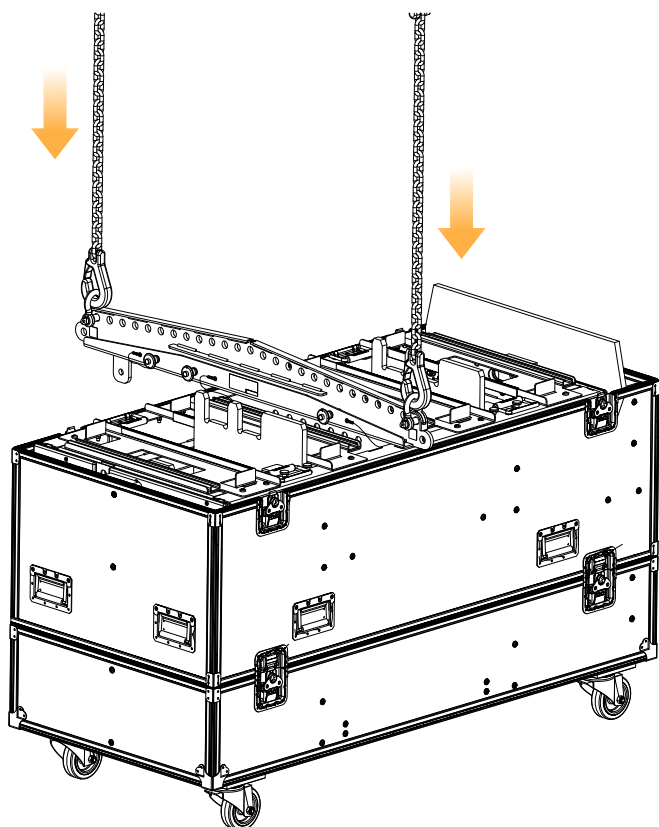

6. Secure CS1-BAR using the two ball-locking pins.

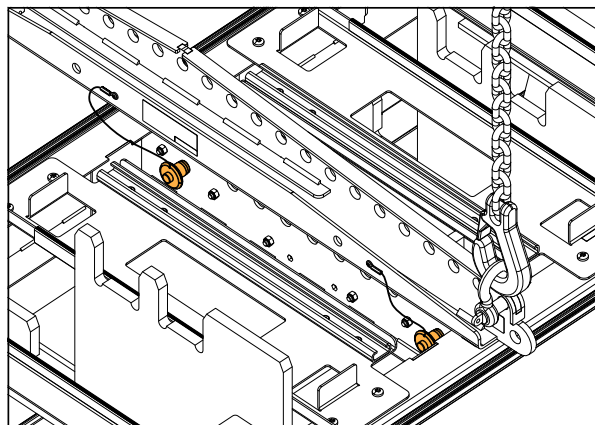
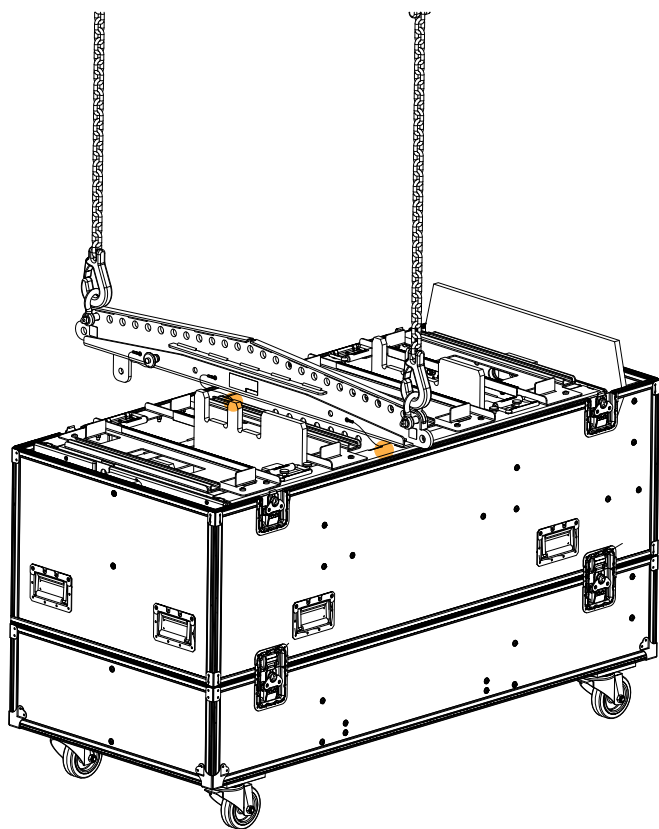

7. Optional:

- Secure an adjustable extension chain to the front external shackle.
- Secure K1-DELTA to the rear external shackle.

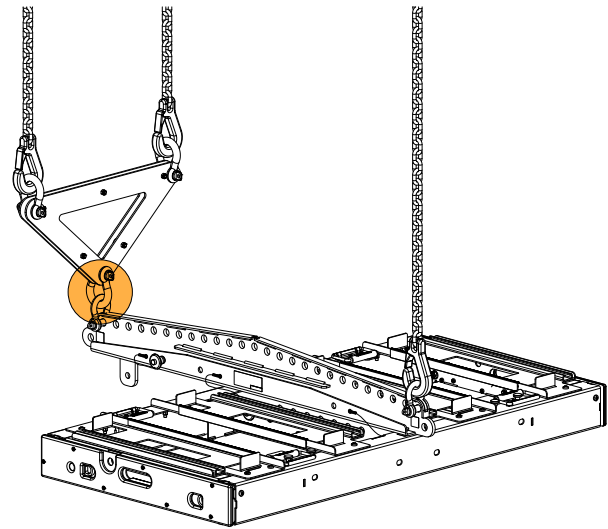
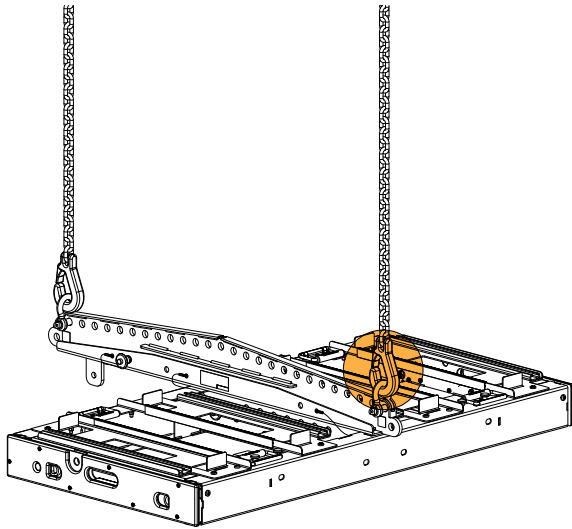

8. Lift CS1-BUMP using the motors.

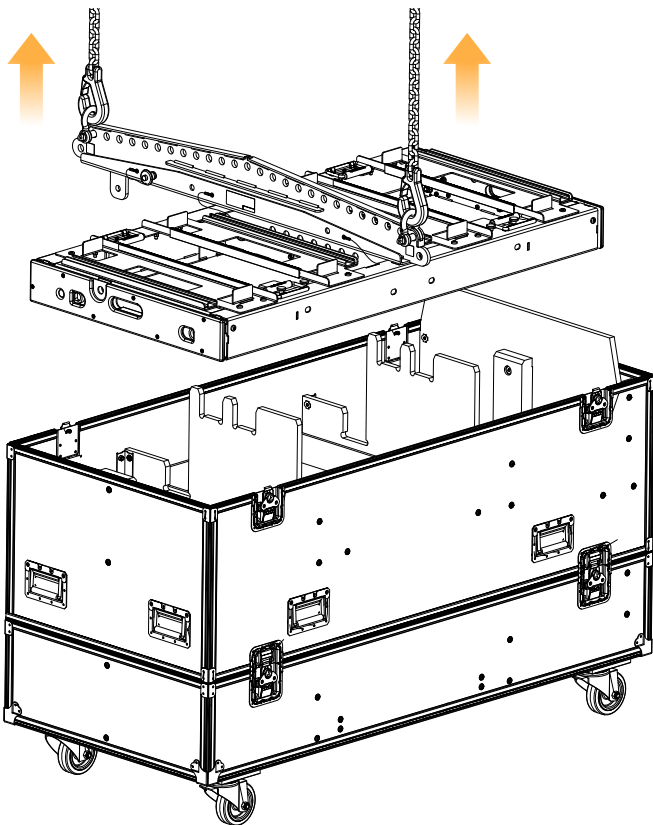

## Securing LA-RAK III / LA-RAK II AVB on CS1-BUMP with L1CS1-RAKMOUNT

<b>Type of deployment</b>	flown array
<b>Rigging accessories</b>	CS1-BUMP L1CS1-RAKMOUNT 16 M8×30 screws (provided with L1CS1-RAKMOUNT) 1 CS1-BAR 2 × Ø19 mm shackles WLL 3.25 t
<b>Tools</b>	torque screwdriver (2 - 10 N.m) T40 Torx bit
<b>Min number of operators</b>	2

**⚠ Risk of falling objects**  
Verify that no unattached items remain on the product or assembly.

**⚠ Mechanical safety**  
A maximum of two racks can be stacked on top of CS1-BUMP.  
A maximum of four racks can be stacked on top of L1-BUMP.

**⚠** Check the sticker at the front of CS1-BUMP to identify the sides.

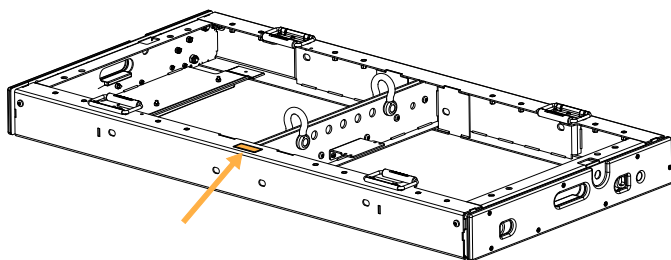

**i** Follow the same procedure for L1-BUMP and L1-BAR.

### Prerequisite

The rigging frame is ready for rigging and placed on the ground.

See [Preparing CS1-BUMP for rigging](#) (p.39).

## Procedure

1. Secure the four rails of L1CS1-RAKMOUNT to CS1-BUMP with the 16 M8×30 screws.  
Use the torque screwdriver. Set the torque to 5 N.m.

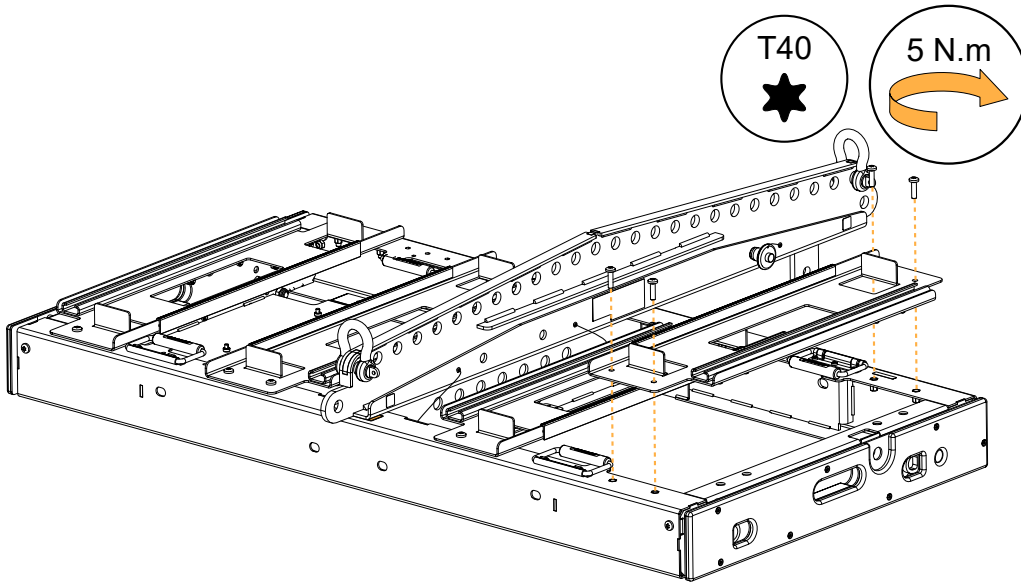

### Risk of crushing injury

Make sure the rack doors are secured with the safety pin.

Refer to the **LA-RAK III / LA-RAK II AVB owner's manual** for more information.

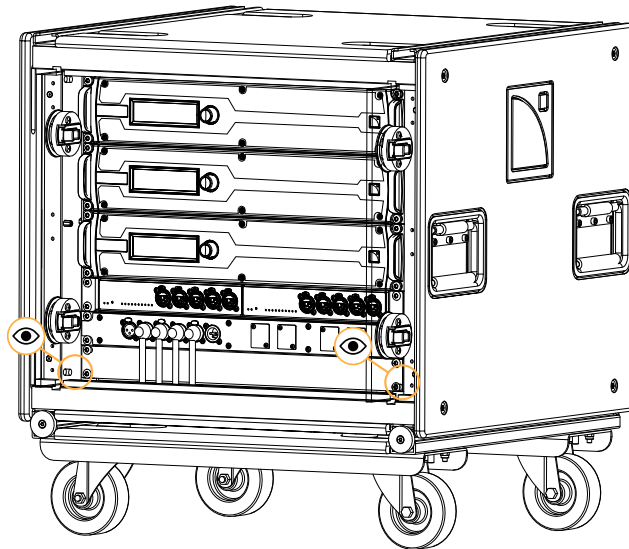
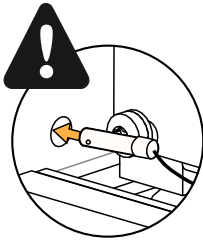

## 2. Remove the coupling bars from rack.



### Risk of damage to the product

Do not rotate the spring-loaded safety more than 90° from its resting position.

Make sure that the spring-loaded safety is aligned with the coupling bar before pulling on it.

Turn the spring-loaded safety mechanisms to release the bars and slide them out.

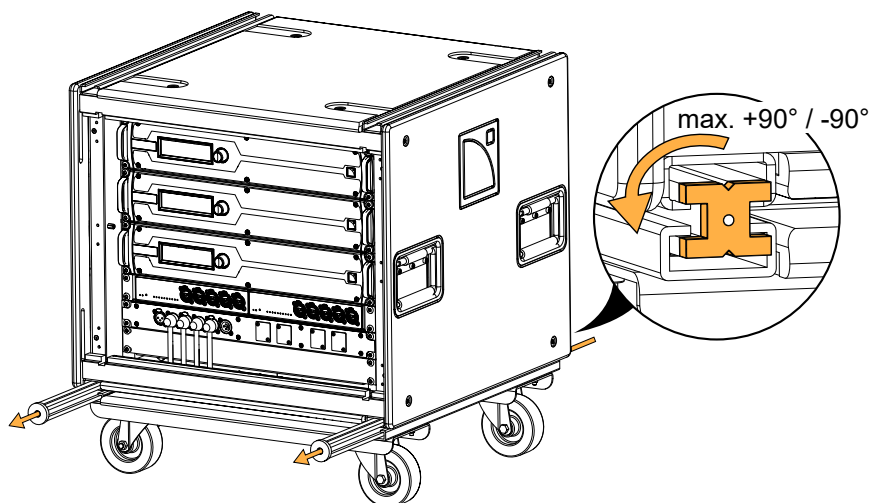

### Risk of crushing injury

Make sure the front of the rack is oriented toward the front of the array.

Check the sticker on the front of CS1-BUMP to identify the sides.

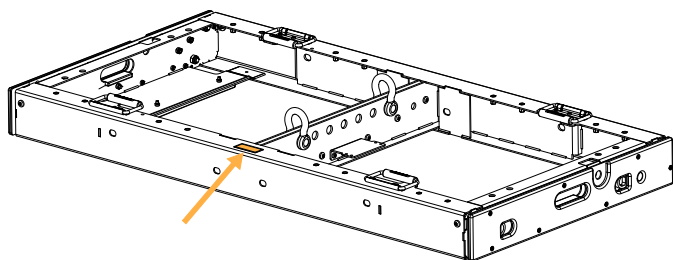

## 3. Position a first rack on the rails.

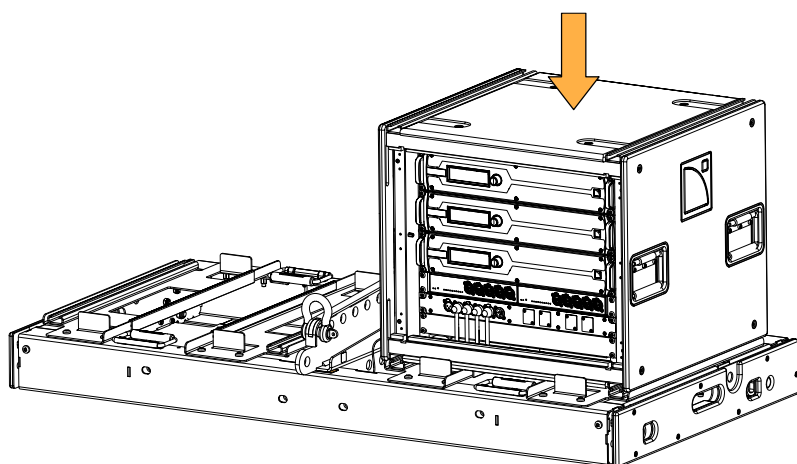

4. Secure the rack with the coupling bars.



**Always insert the coupling bars so that the round safety mechanisms are pointed upward (depending on the site angle):**

from the back for a negative angle (rear extension)  
 from the front for a positive angle (front extension)

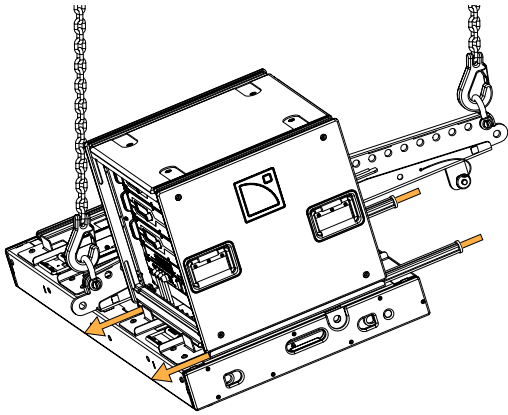

For a negative site angle

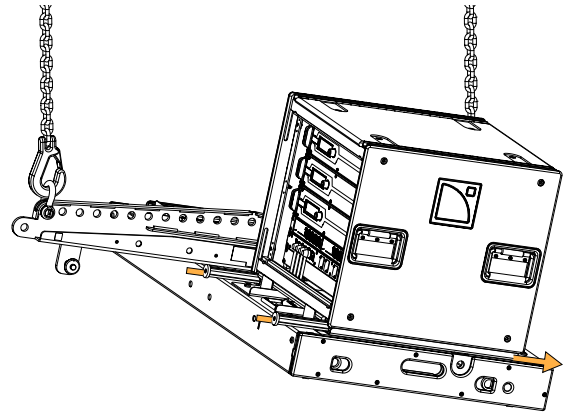

For a positive site angle

Insert the spring-loaded safety in the rack rails, give a quarter turn and slide the bar until the safety locks into place.

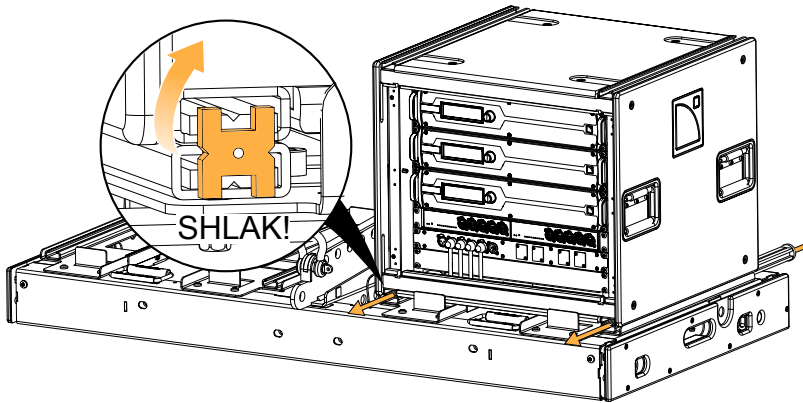

5. Repeat steps from 3 to 5 to secure a second rack on CS1-BUMP.



**Risk of falling**

Place the two racks directly onto CS1-BUMP.

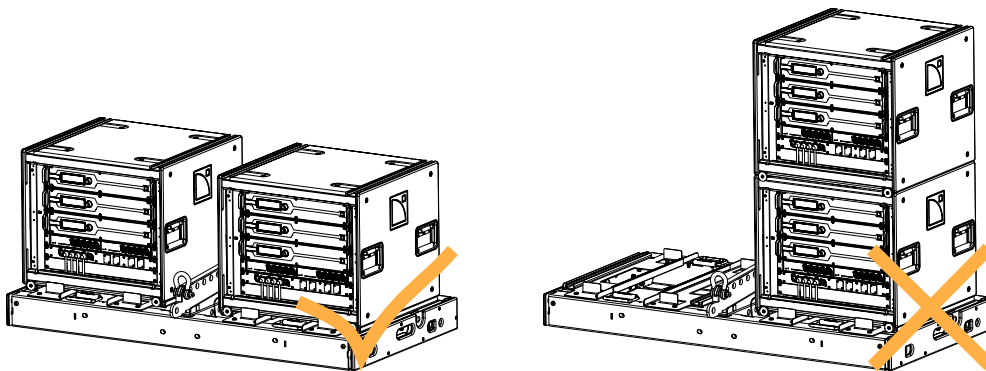

6. Release the rack stabilizer locking system by raising and turning the handle.

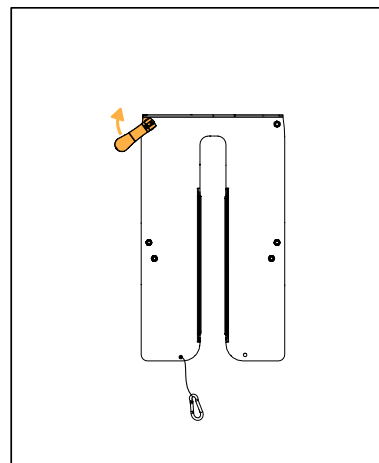
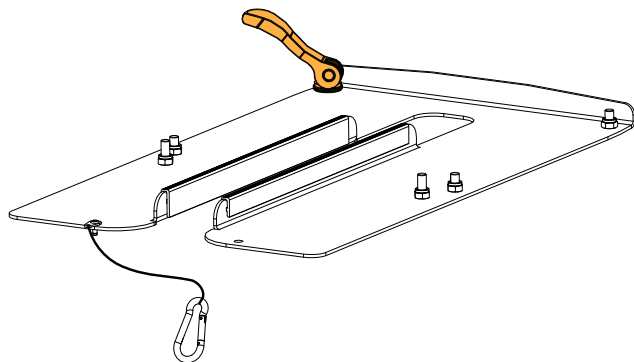

7. Slide the rack stabilizer along the top rack rails until it locks:

- From the front side when using CS1-BAR as a rear extension.

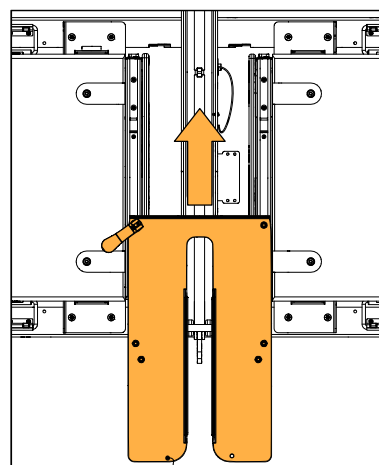
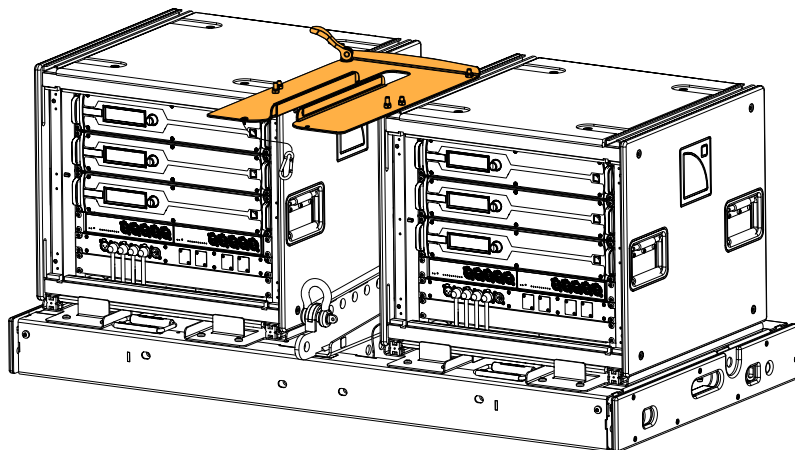

- From the rear side when using CS1-BAR as a front extension.

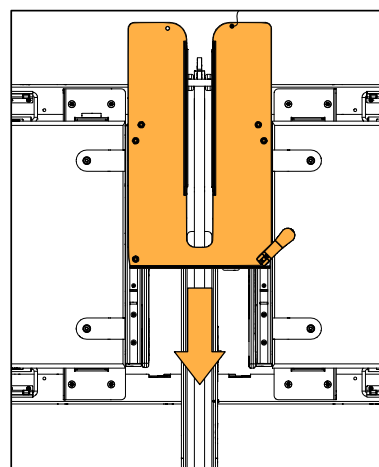
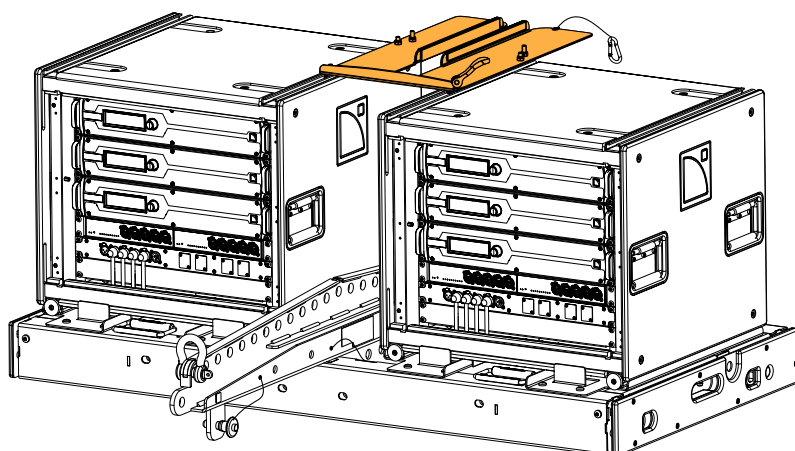

8. Secure the stabilizer by turning and lowering the handle.

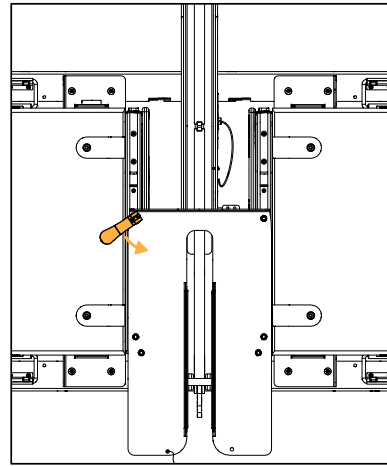
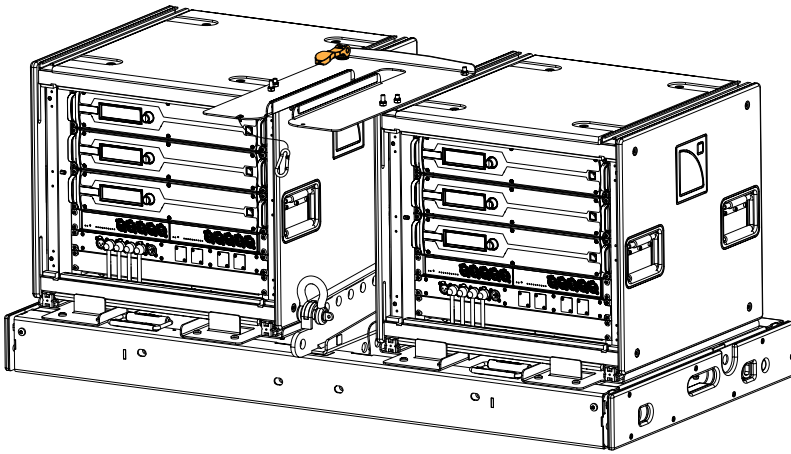

9. Secure the motor hooks to CS1-BAR.

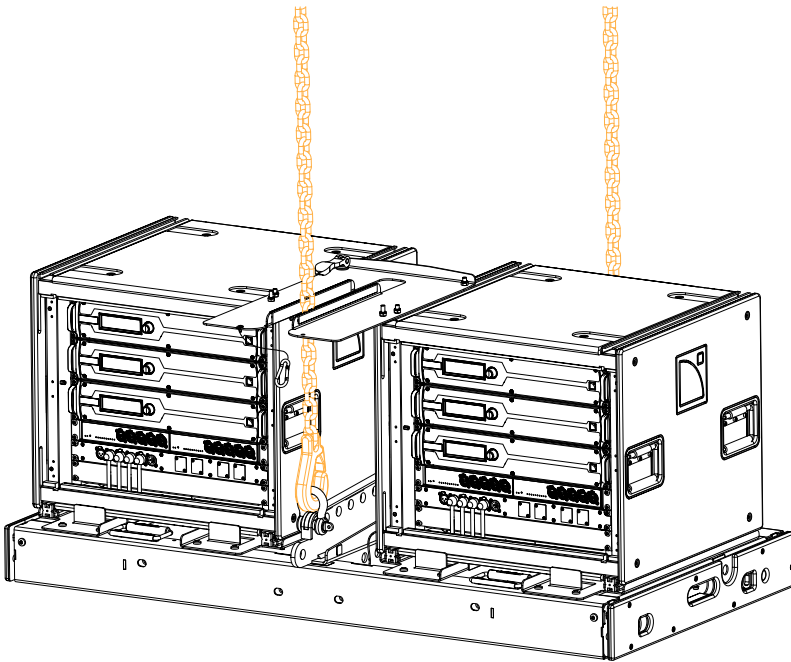

10. Secure the rack stabilizer tether.

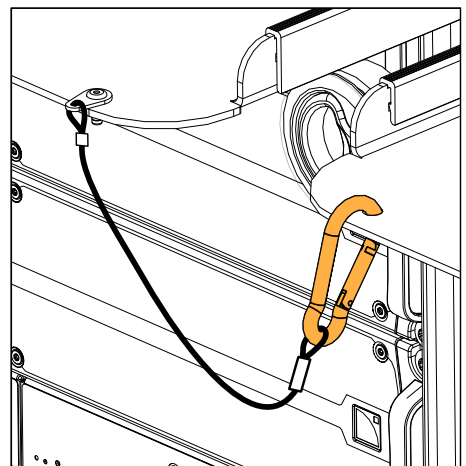
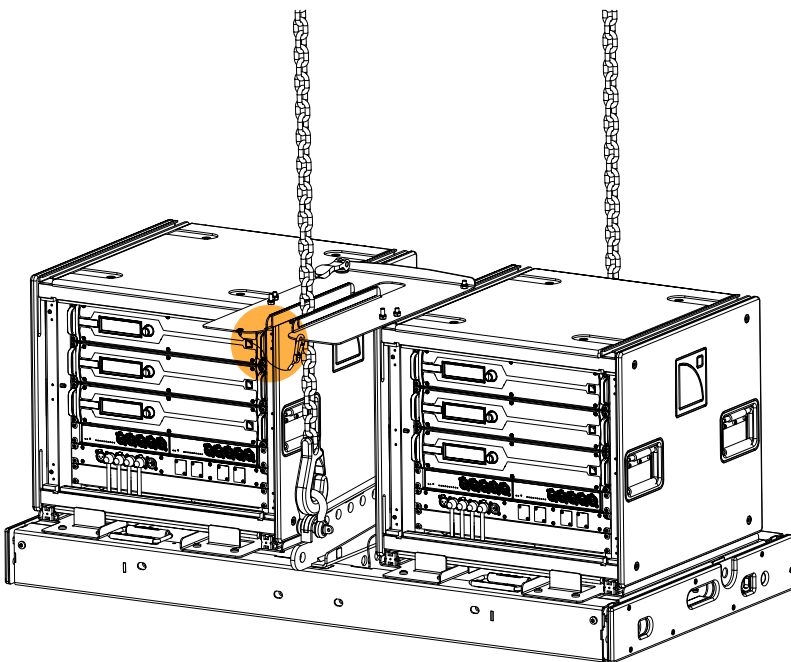

## Flying

### Flying CS1

Type of deployment	flown array
Rigging accessories	CS1-BUMP 1 CS1-BAR (optional) 2 × Ø22 mm shackles WLL 4.75 t
Min number of operators	2

**!** **Heavy load: one CS1 weighs 180 kg (without rigging accessories or cables)**  
CS1 must be lifted by a lifting device.

**!** **Risk of falling objects**  
Verify that no unattached items remain on the product or assembly.

**!** **Additional safety for flown arrays**  
When flying an array, use available holes to implement a secondary safety.

**i** Follow the same procedure for L1-BUMP and L1-BAR.

#### Prerequisite

The rigging frame is ready for rigging.

See [Preparing CS1-BUMP for rigging](#) (p.39).

LA-RAK III is secured on the rigging frame (optional).

See [Securing LA-RAK III / LA-RAK II AVB on CS1-BUMP with L1CS1-RAKMOUNT](#) (p.43).

#### Procedure

**!** **Risk of pinching fingers**  
Hold the rigging frame from the top when positioning it on CS1.

1. Position CS1-BUMP on top of CS1. Align the runners with the tracks.

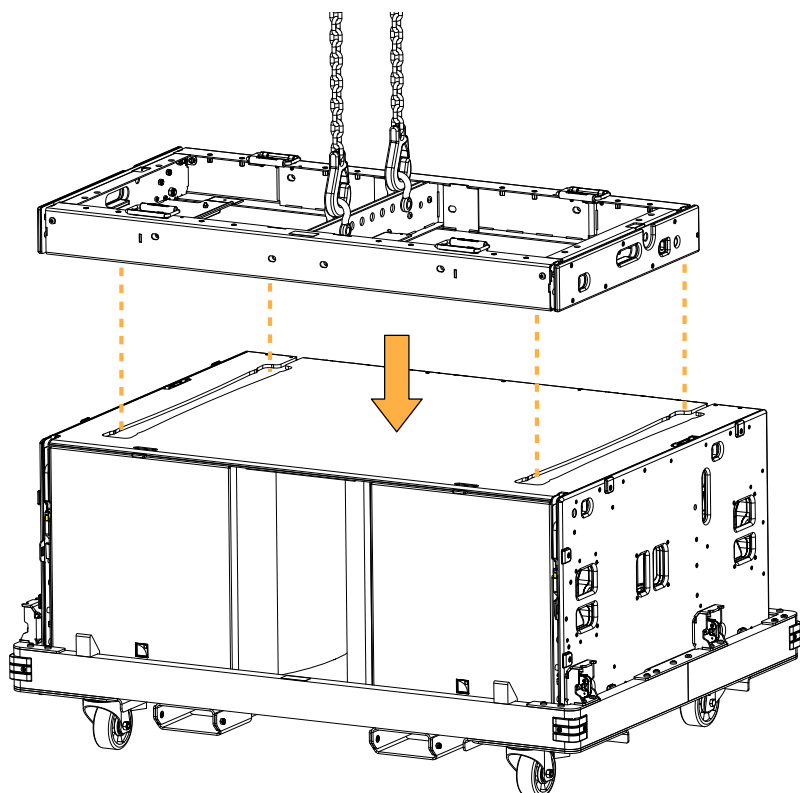

2. Pull on the front latches and rotate the front rigging arms of the enclosure.

The latches of CS1-BUMP slide out slightly and come back into their positions.

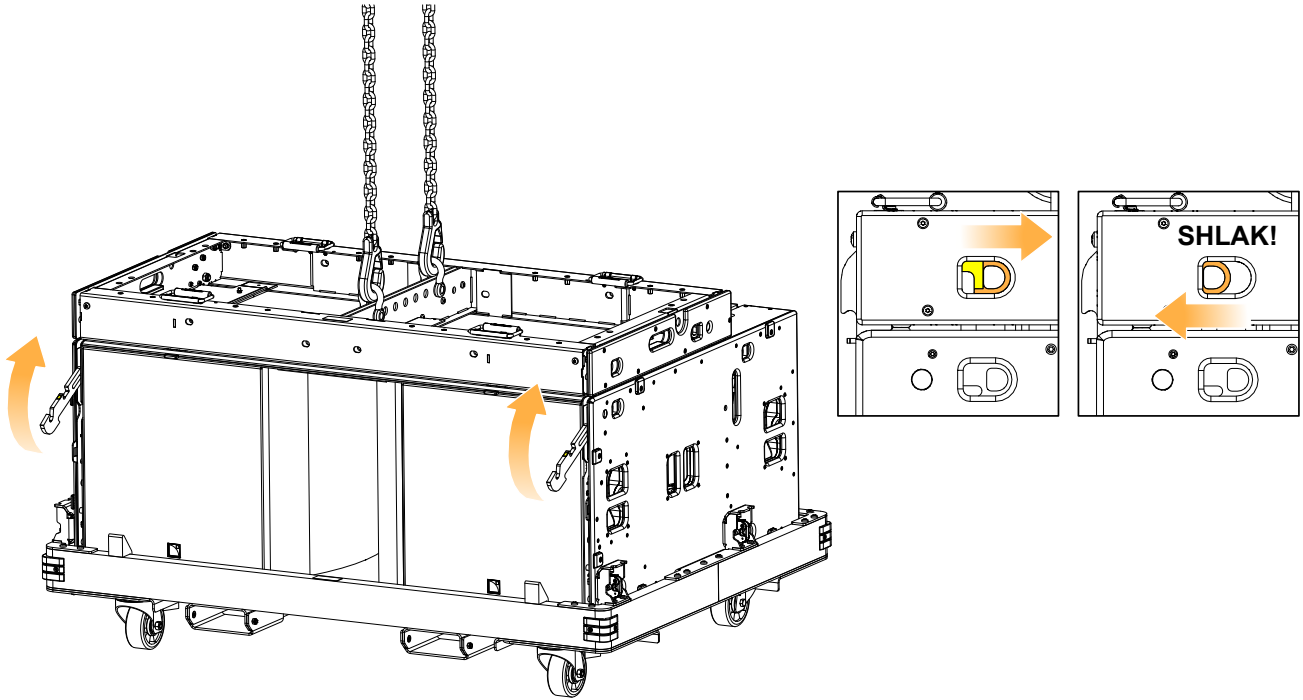

3. Press the front buttons on both sides of the enclosure to activate the automatic locking system.

The latches retract when the button is pushed (no yellow label visible).

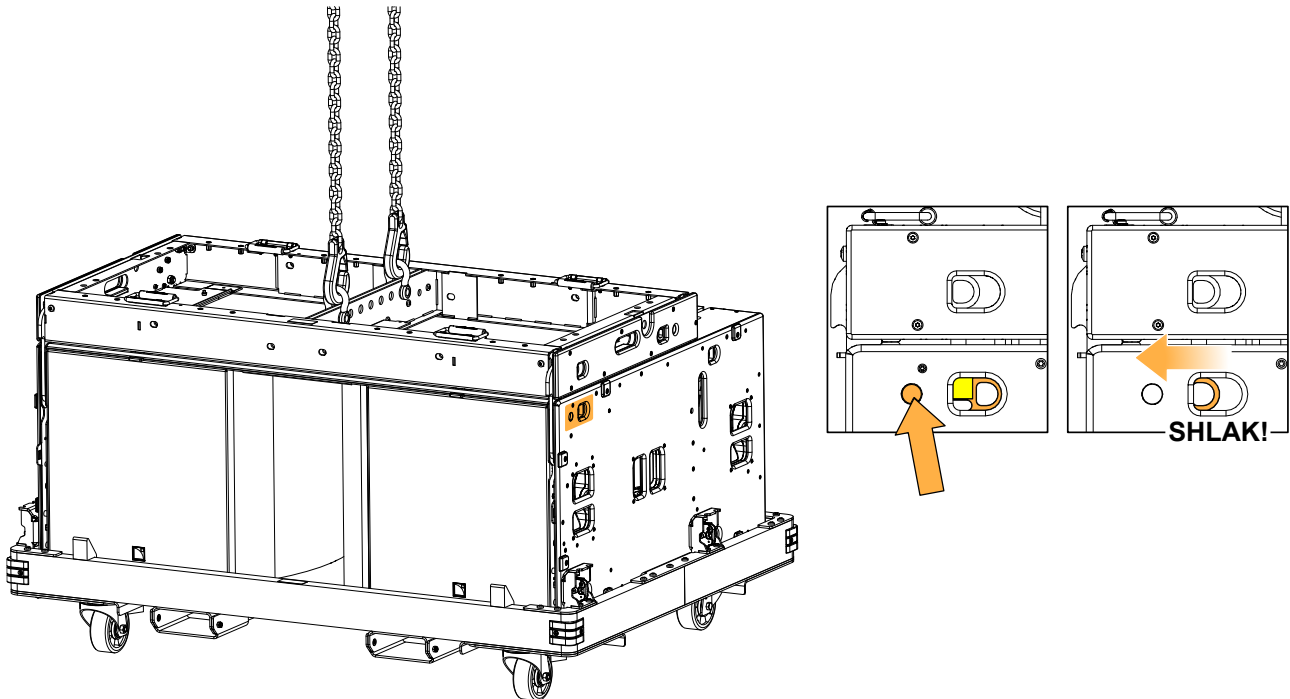

4. If necessary, pull on the rear latches of L1-BUMP to deactivate the locking system.



When the locking system is deactivated, a yellow label is visible on the latch.

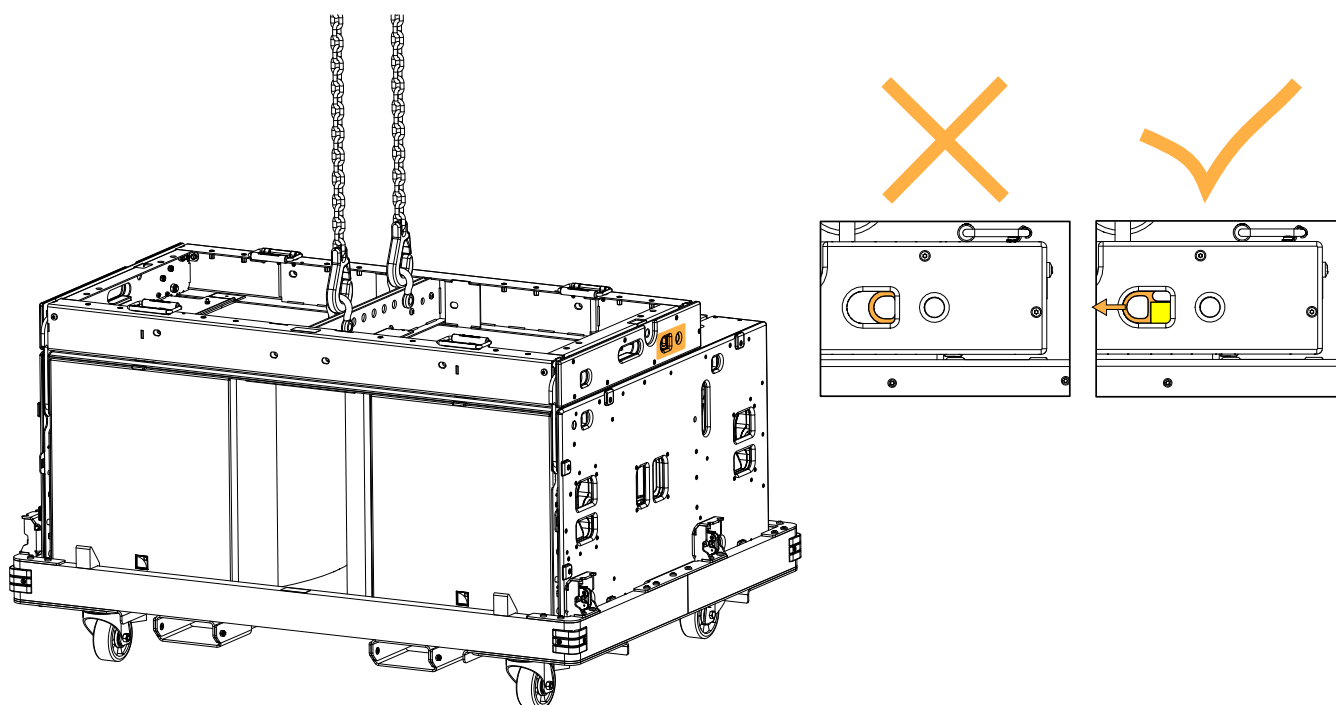

5. Pull on the rear latches of the enclosure while sliding up the rear rigging arms.

Release the latches to lock the rigging arms in position.

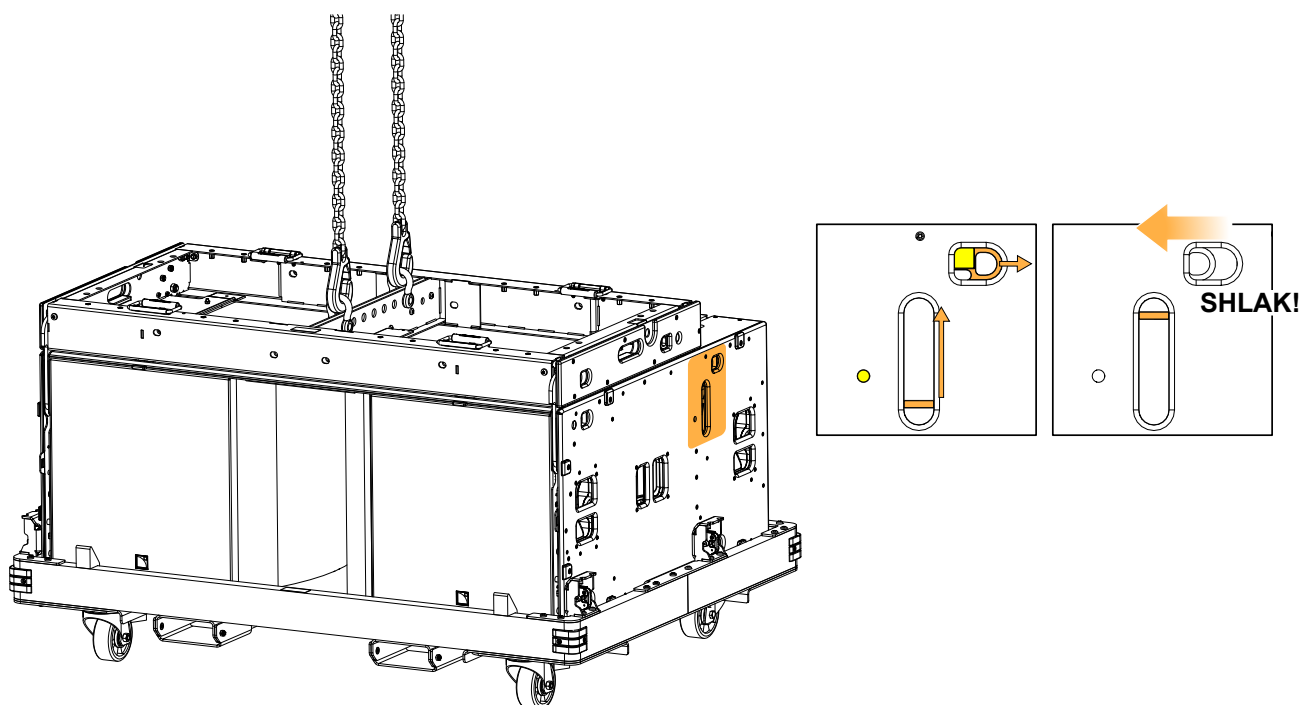

6. Press the buttons on both sides of CS1-BUMP to activate the automatic locking system.

The latches retract when the button is pushed (no yellow label visible).

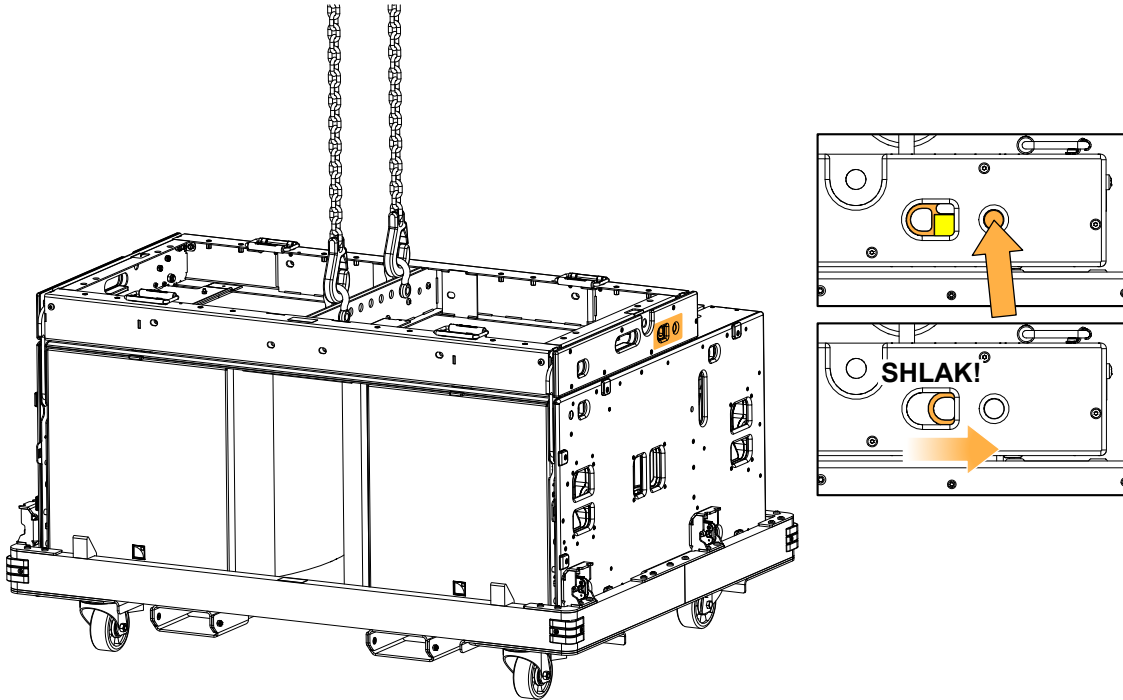

To extend the site angle capability, secure one CS1-BAR on CS1-BUMP using pins.

CS1-BAR can be attached as a rear or a front extension, in position A or B.

7. Select the pickup points on the rigging element.
8. Pull the four latches to disengage the chariot from the enclosure.

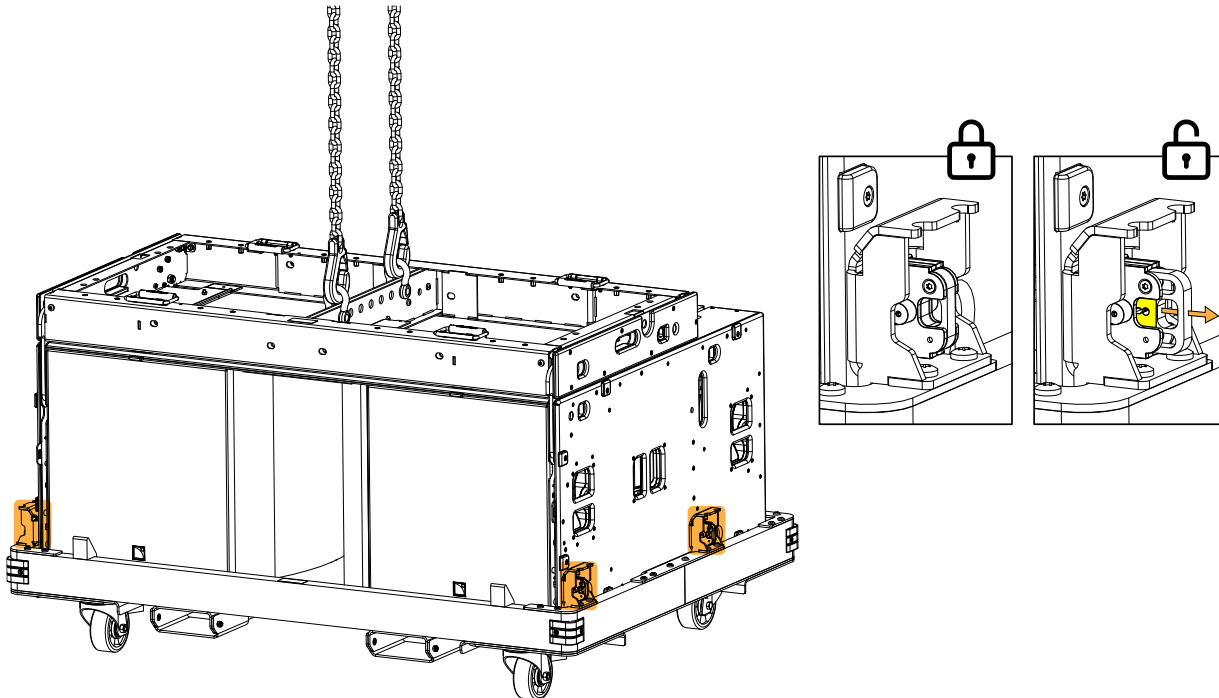

9. Raise the array.

## Adding CS1 to an array

Type of deployment	flown array
Min number of operators	2

**⚠ Heavy load: one CS1 weighs 180 kg (without rigging accessories or cables)**  
CS1 must be lifted by a lifting device.

**⚠ Risk of falling objects**  
Verify that no unattached items remain on the product or assembly.

**⚠ Additional safety for flown arrays**  
When flying an array, use available holes to implement a secondary safety.

### Prerequisite

A first CS1 is secured to the rigging frame. See [Flying CS1](#) (p.49).

### Procedure

1. Position the enclosure below the array.

**⚠ Risk of crushing injury**  
Always use the handles to guide the upper enclosure.

2. Lower the array until the ground runners of the top enclosure meet the matching tracks of the bottom enclosure.

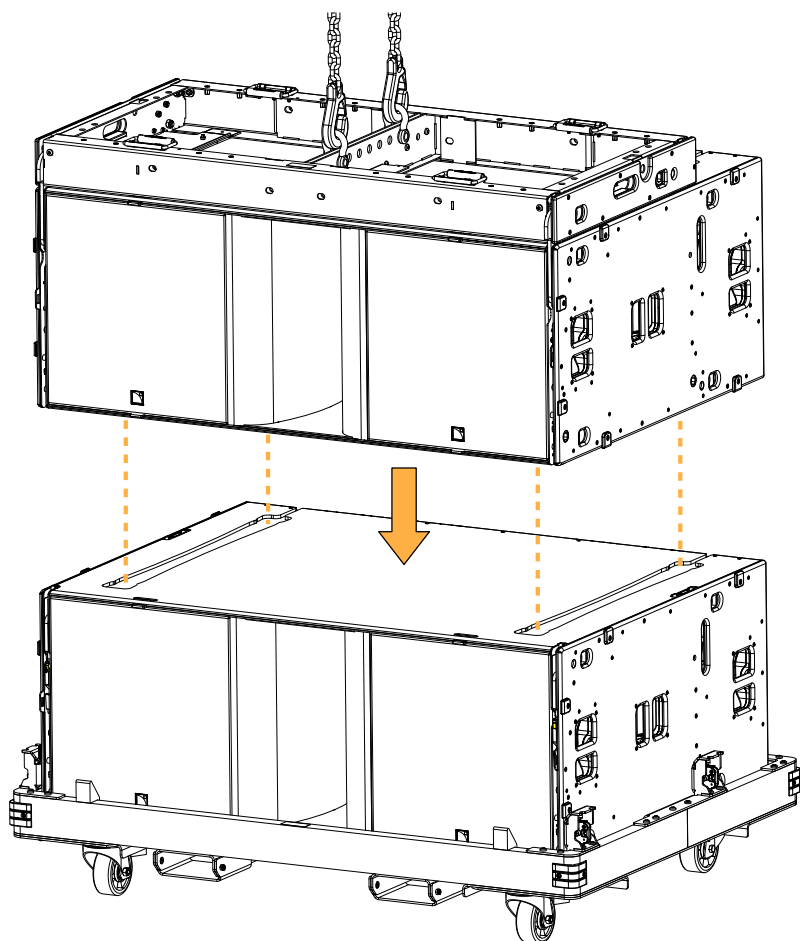

3. Pull on the front latches and rotate the front rigging arms of the bottom enclosure. Connect the front rigging arms to the top enclosure rigging points.

The latches of the top enclosure slide out slightly and come back into their positions.

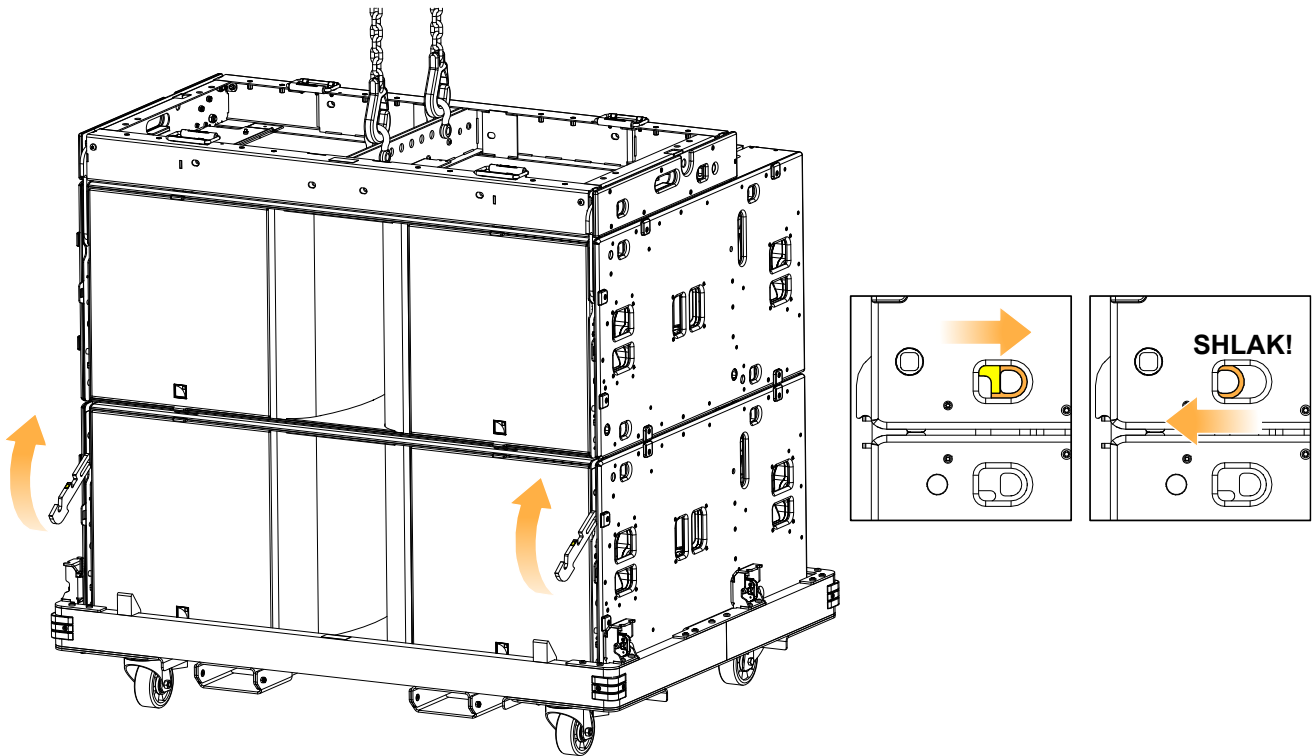

4. Press the buttons on both sides of the bottom enclosure to activate the automatic locking system.

The latches retract when the button is pushed (no yellow label visible).

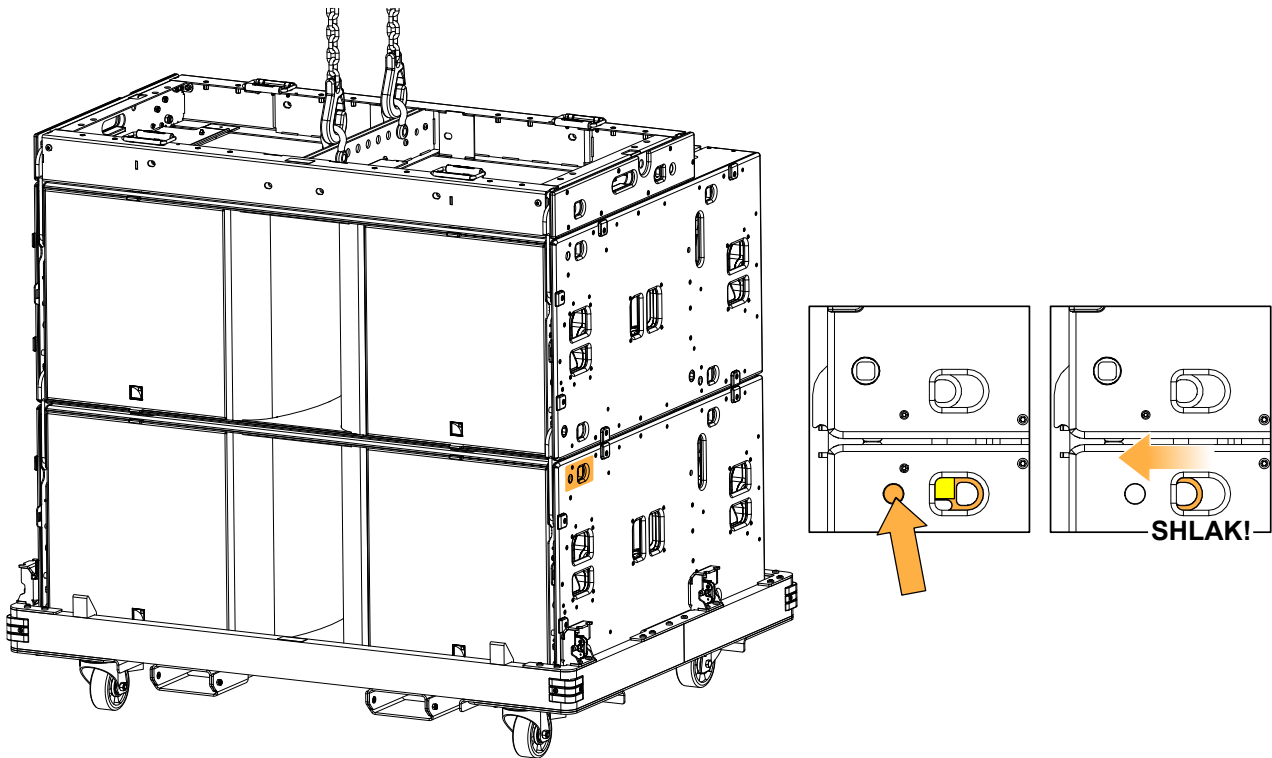

5. If necessary, pull on the rear latches of the top enclosure to deactivate the locking system.



When the locking system is deactivated, a yellow label is visible on the latch.

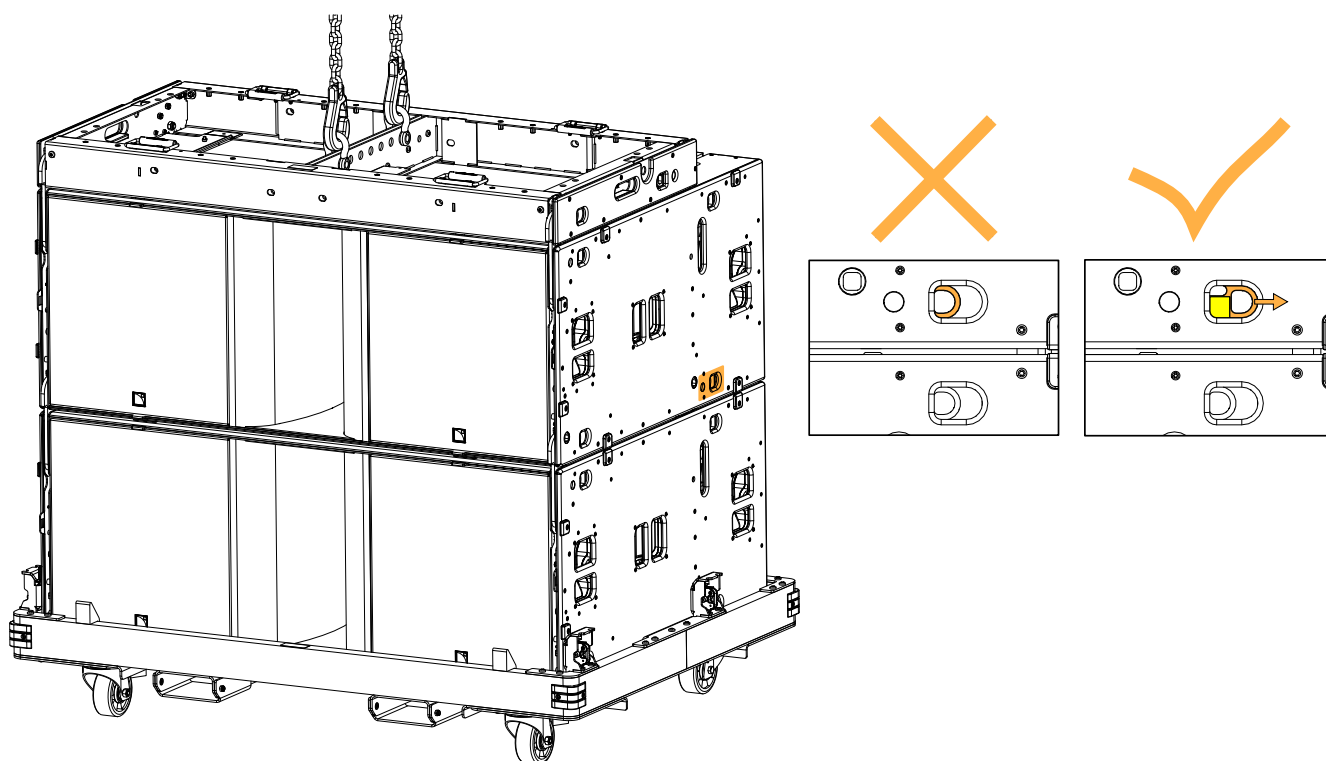

6. Pull on the rear latches of the bottom enclosure while sliding up the rear rigging arms.

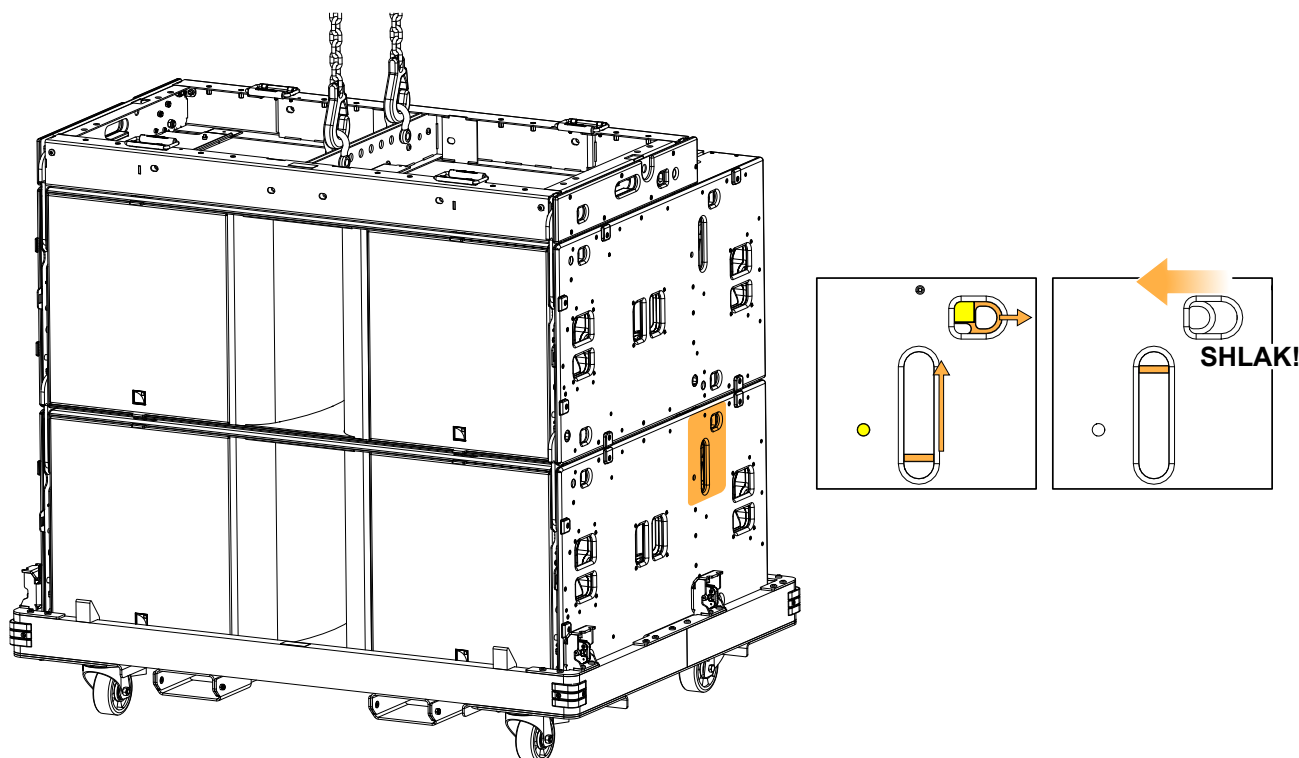

- Press the buttons on both sides of the top enclosure to activate the automatic locking system.

The latches retract when the button is pushed (no yellow label visible).

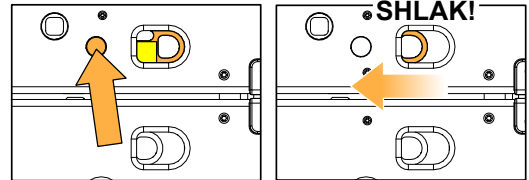
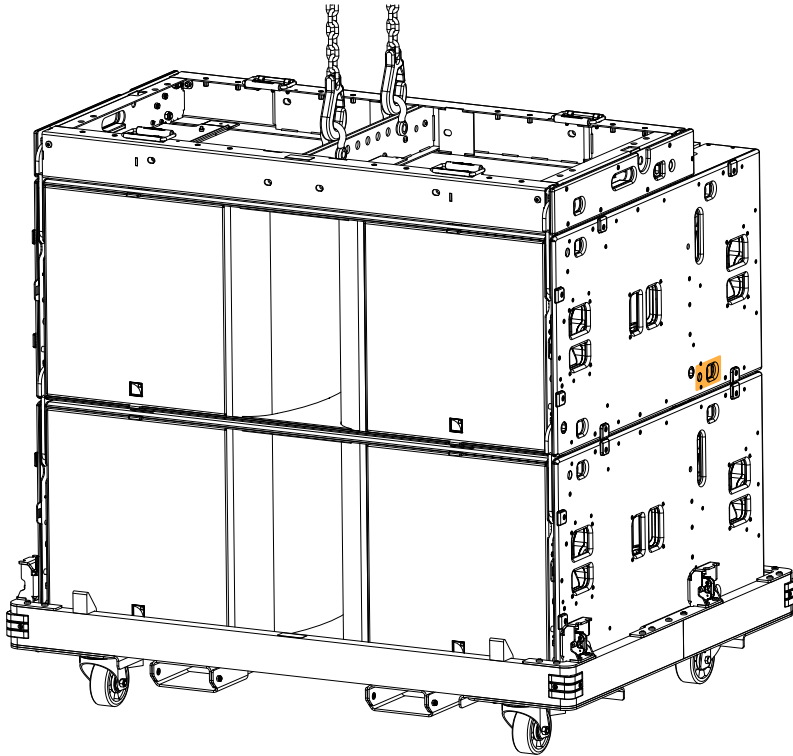

- Pull the four latches to disengage the chariot from the enclosure.

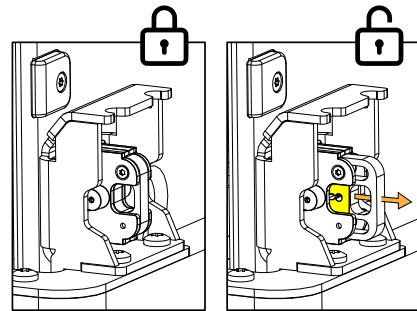
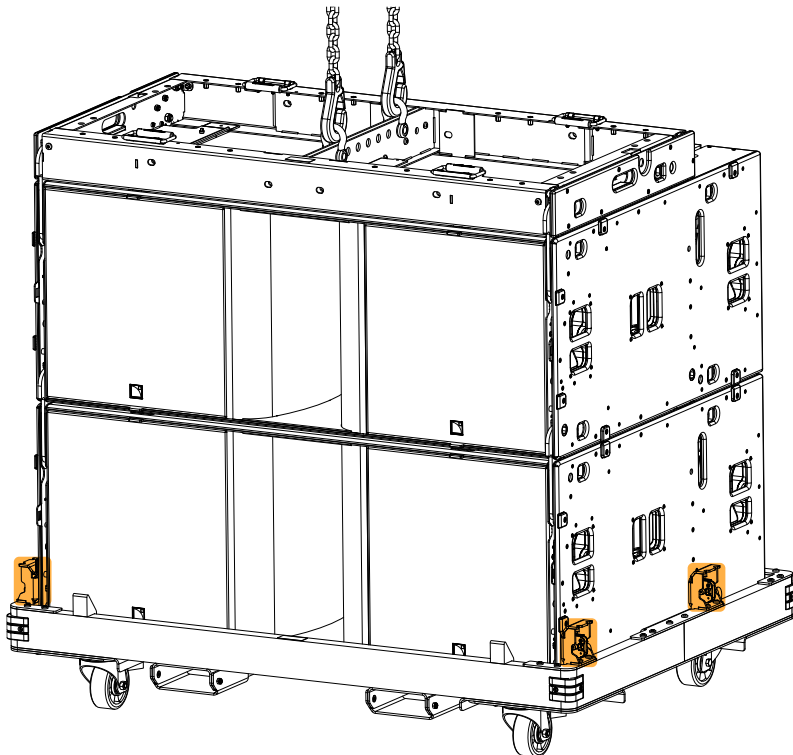

- Raise the array.

## Removing CS1 from an array using CS1-PLA

Rigging accessories	CS1-PLA
Min number of operators	2

### Procedure

1. Carefully lower the assembly until the bottom enclosure rests on the ground.
2. Pull the rear latches to deactivate the locking system.

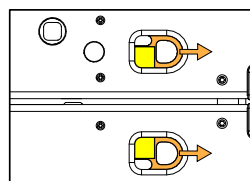
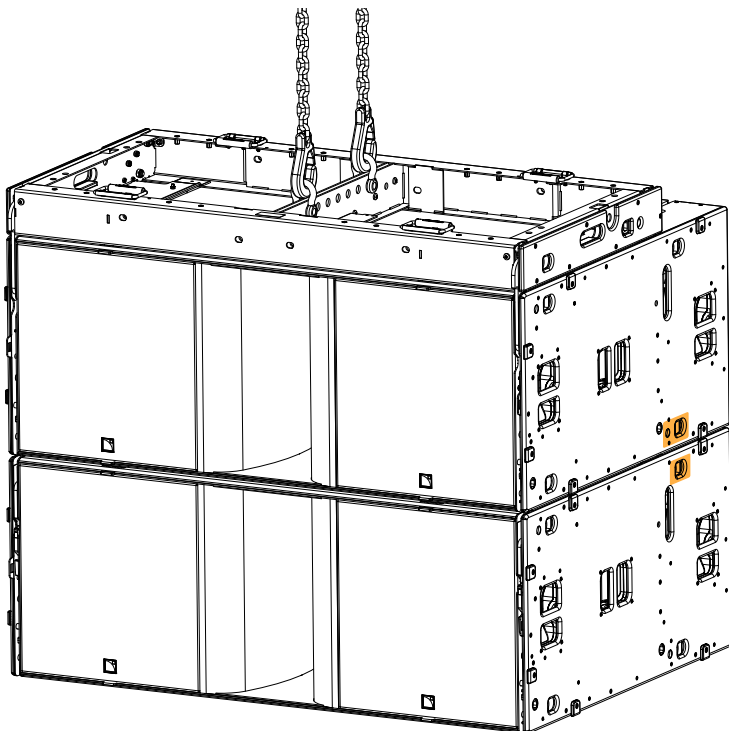

3. Slide down the rear rigging arms.

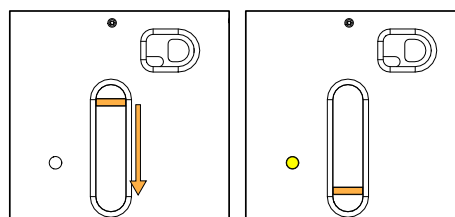
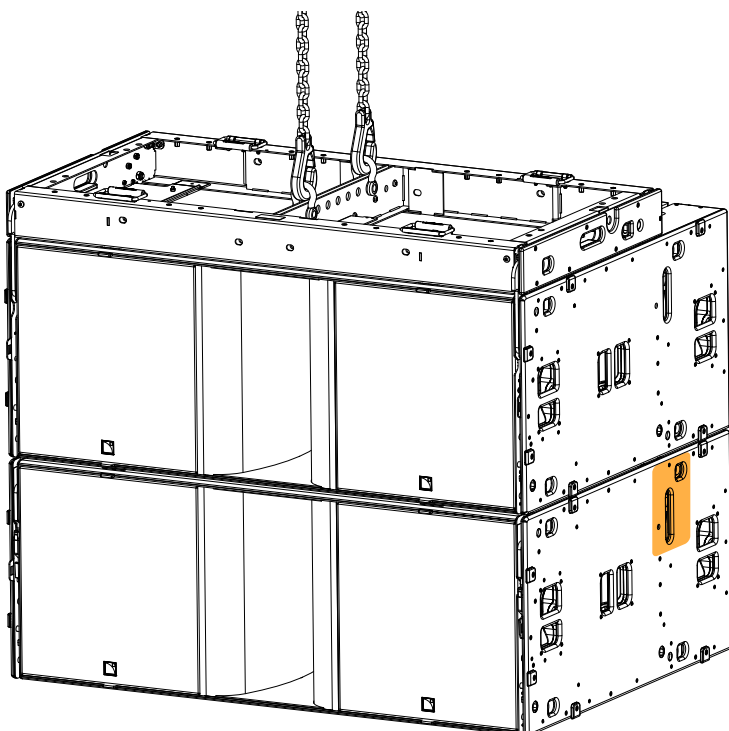

4. Pull the front latches of the bottom enclosure to deactivate the locking system.

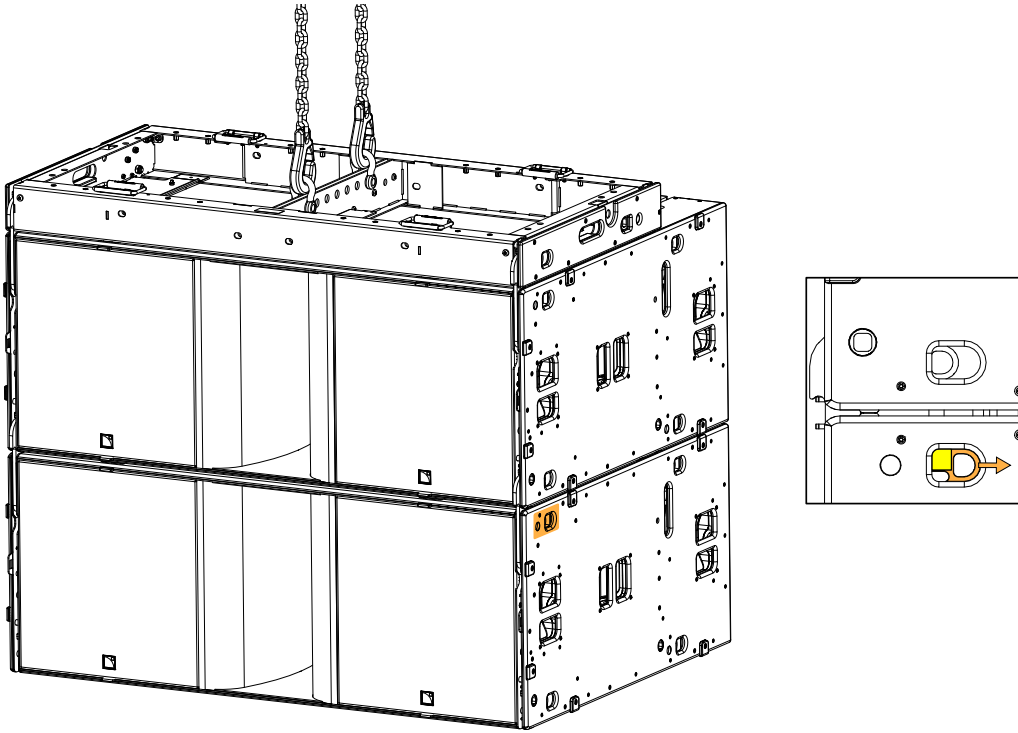

5. Pull on the front latches of the top enclosure and rotate the front rigging arms of the bottom enclosure.

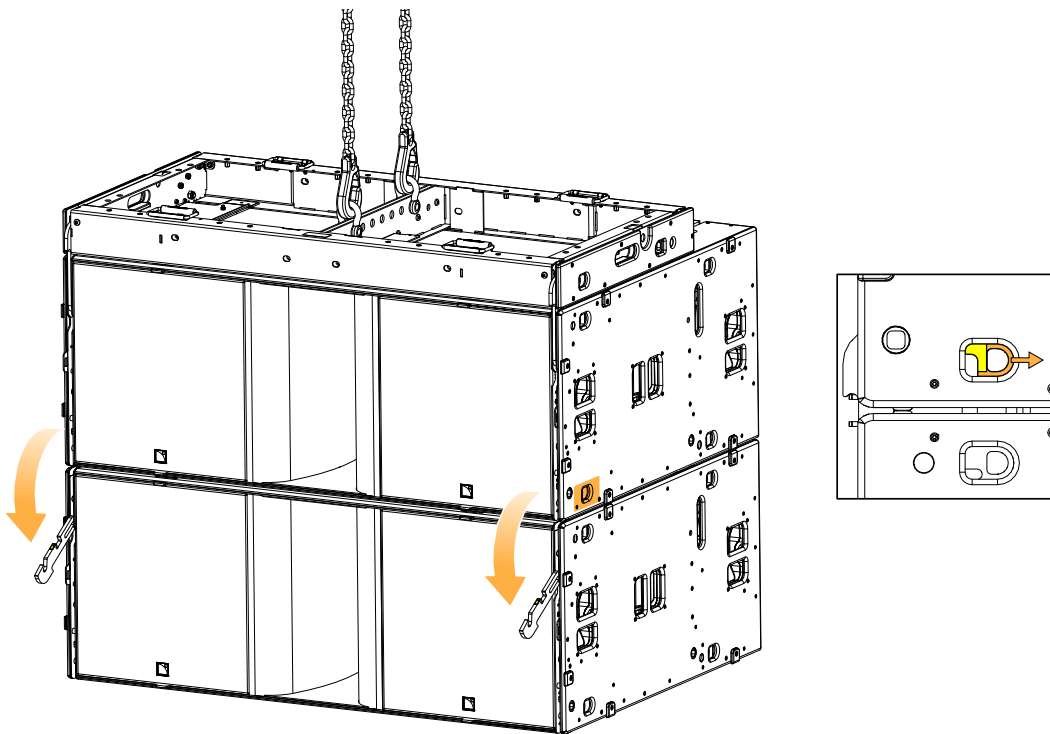

6. Raise the array.

## 7. Secure CS1-PLA to the enclosure:

- a) Position CS1-PLA on the front of the enclosure.

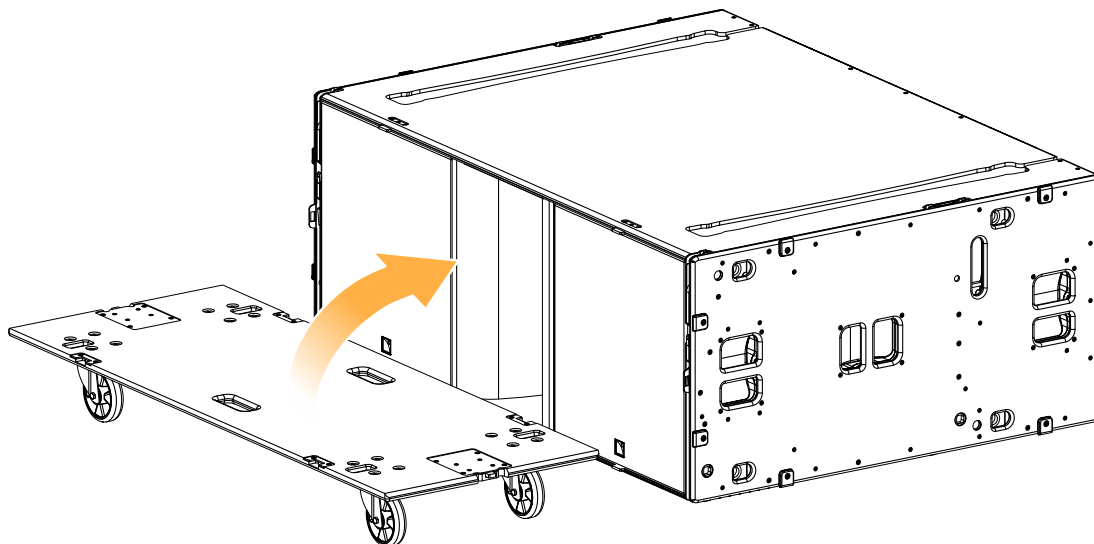

- b) Secure CS1-PLA using the two spring-loaded pins.

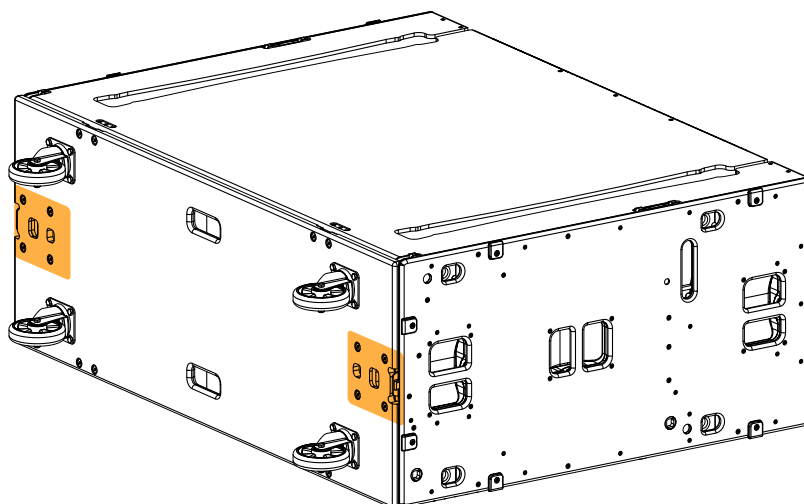
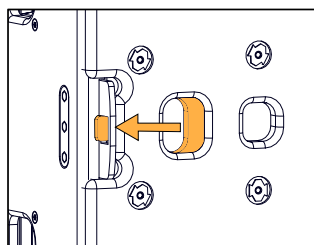

## 8. Put the assembly on its wheels using the enclosure handles.

**Risk of injury**

A minimum of two operators is required to tip CS1 over and put CS1-PLA on its wheels.

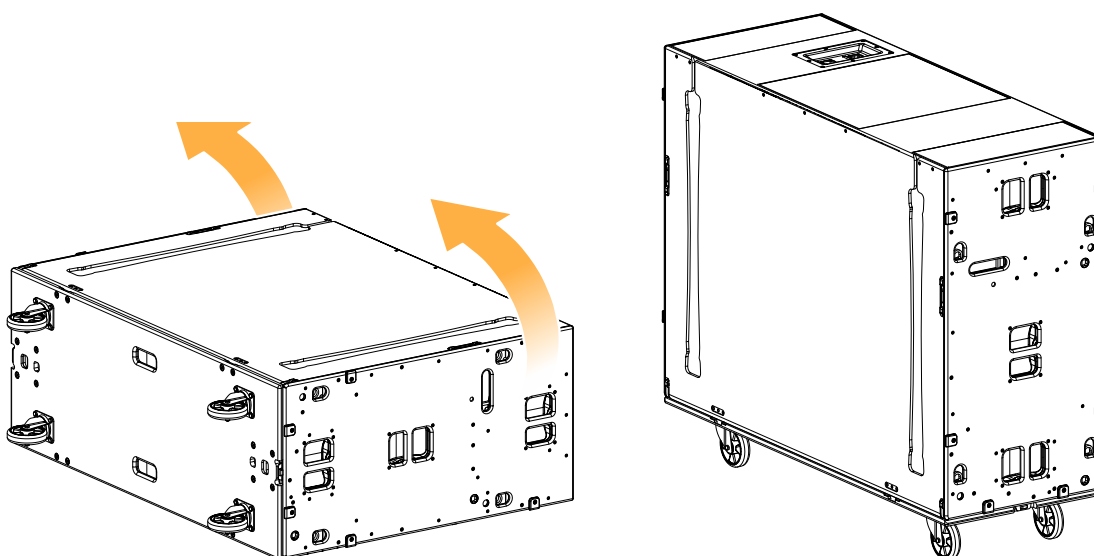

## 9. Remove the enclosure from the rigging location.

## Removing CS1 from an array using CS1-CHARIOT

Rigging accessories	CS1-CHARIOT
Min number of operators	2

### Procedure

1. Position CS1-CHARIOT underneath the array.
2. Carefully lower the assembly until the bottom enclosure rests in CS1-CHARIOT.
3. Secure CS1-CHARIOT to the bottom enclosure.  
Push to engage the latch.

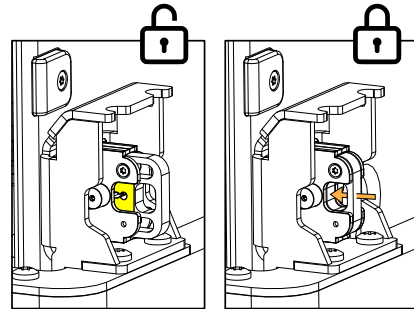
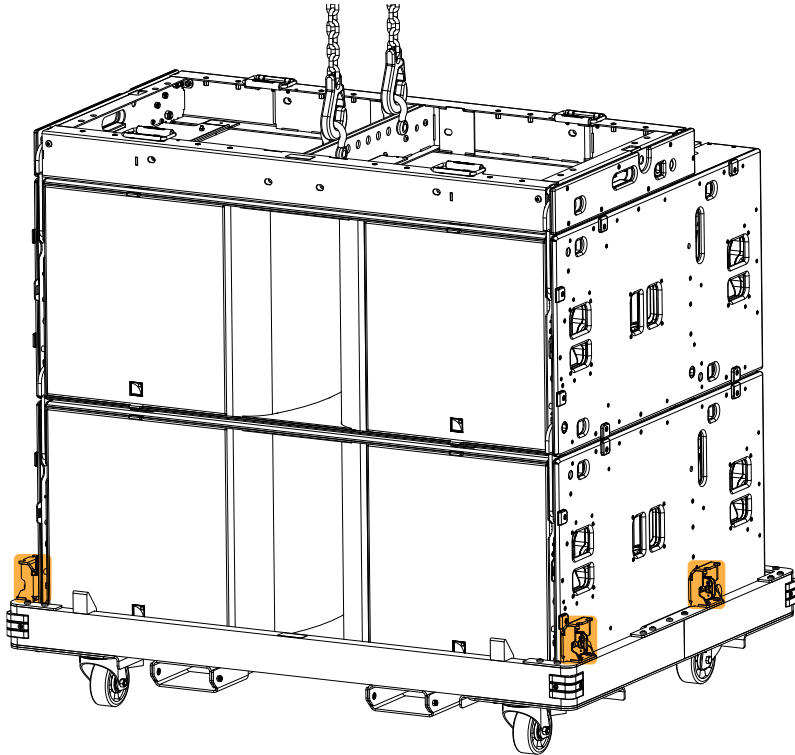

4. Pull the rear latches to deactivate the locking system.

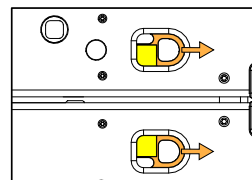
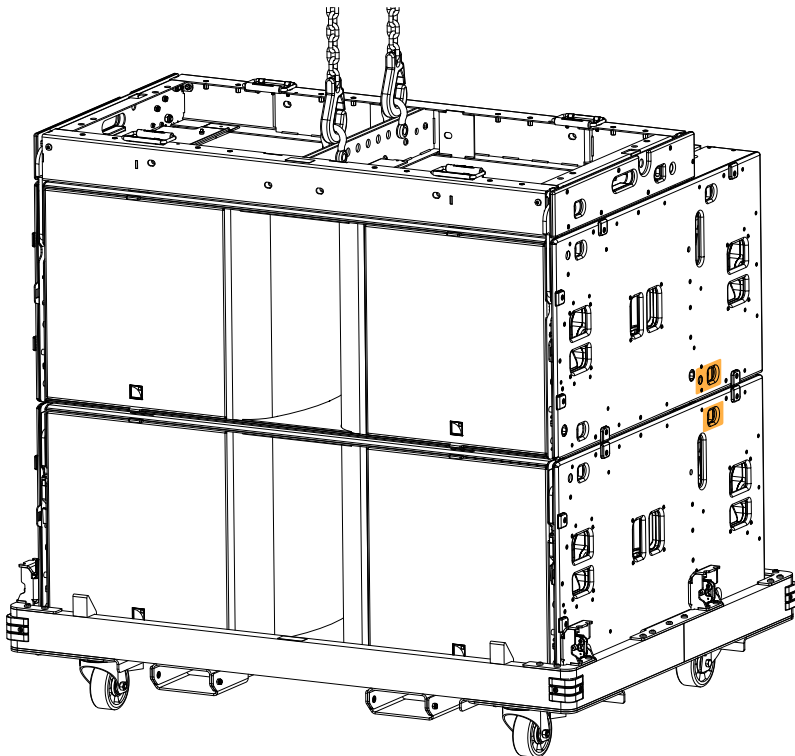

5. Slide down the rear rigging arms.

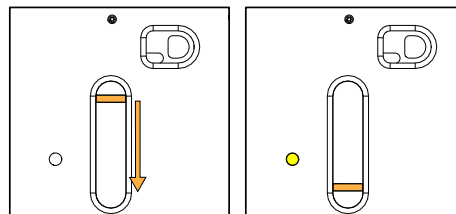
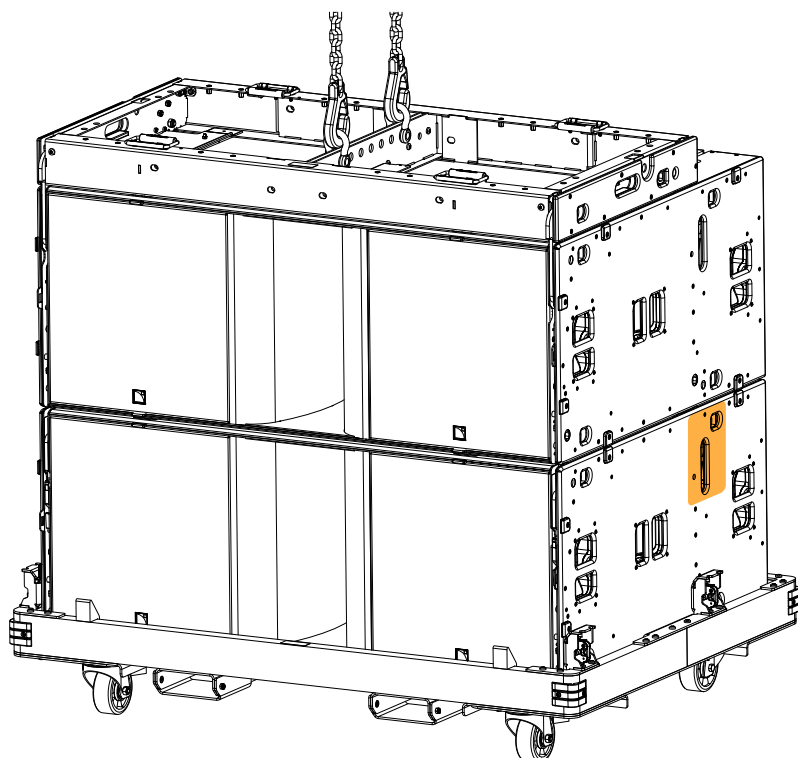

6. Pull the front latches of the bottom enclosure to deactivate the locking system.

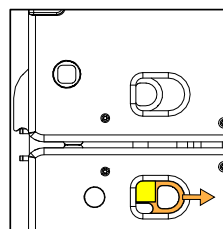
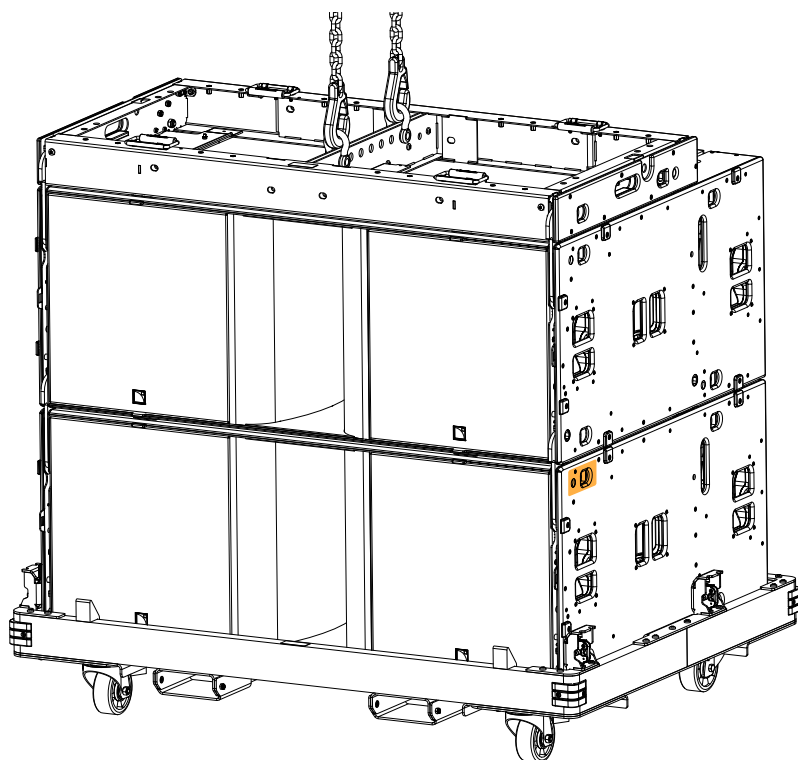

7. Pull on the front latches of the top enclosure and rotate the front rigging arms of the bottom enclosure.

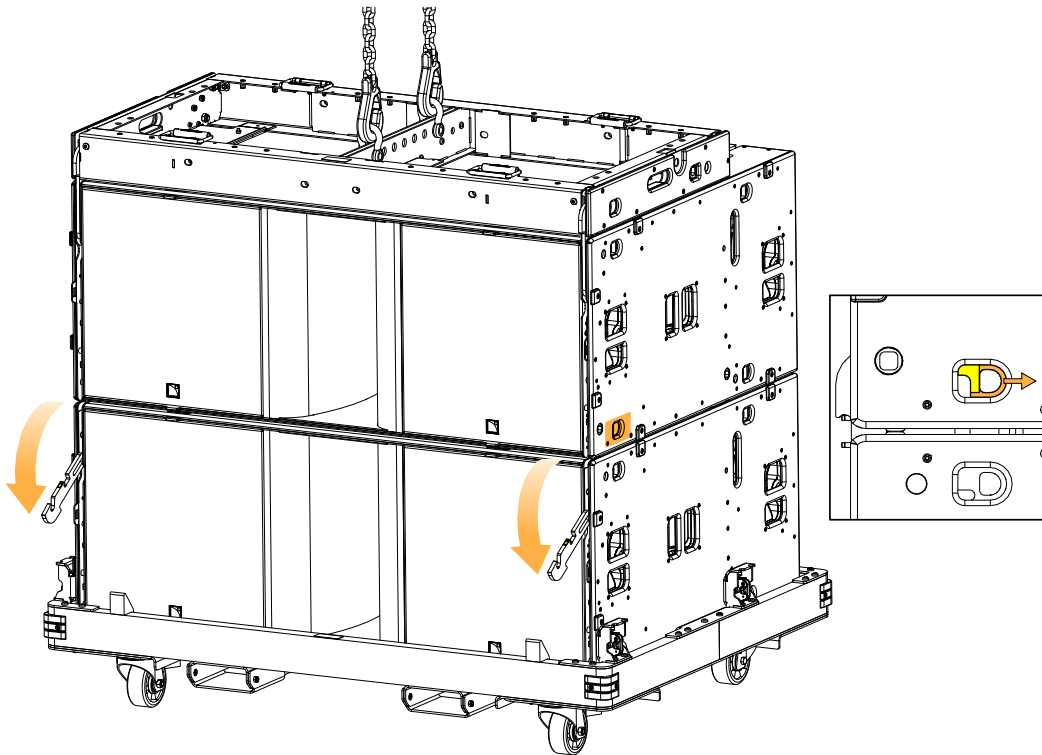

8. Raise the array.

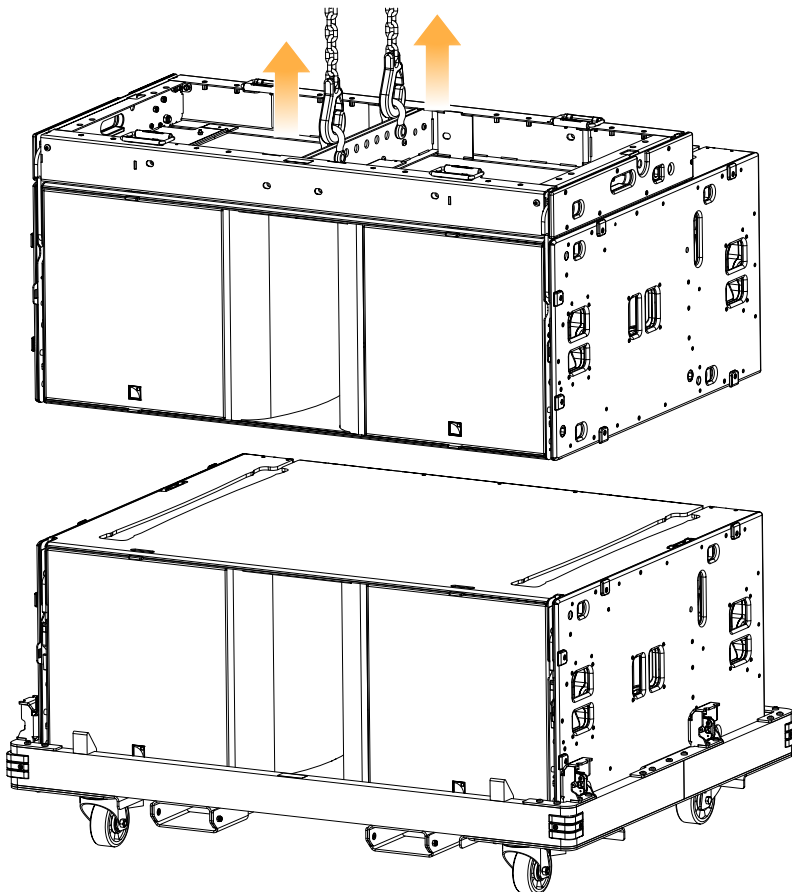

9. Remove the enclosure from the rigging location.

## Stacking

### Stacking CS1 on CS1-CHARIOT

Type of deployment	stacked array
Rigging accessories	CS1-CHARIOT CS1-BUMP or L1-BUMP 2 × Ø22 mm shackles WLL 4.75 t
Min number of operators	2

**!** **Heavy load: one CS1 weighs 180 kg (without rigging accessories or cables)**  
CS1 must be lifted by a lifting device.

**!** **Risk of falling objects**  
Verify that no unattached items remain on the product or assembly.

**!** **A maximum of 4 CS1 can be stacked on CS1-CHARIOT.**  
Refer to [Mechanical safety](#) (p.35).

#### Prerequisite

CS1-BUMP/L1-BUMP is ready for rigging. See [Preparing CS1-BUMP for rigging](#) (p.39).

#### Procedure

1. Place a first CS1 below CS1-BUMP.

**!** **Risk of pinching fingers**  
Hold the rigging frame from the top when positioning it on CS1.

2. Position CS1-BUMP on top of CS1. Align the runner with the tracks.

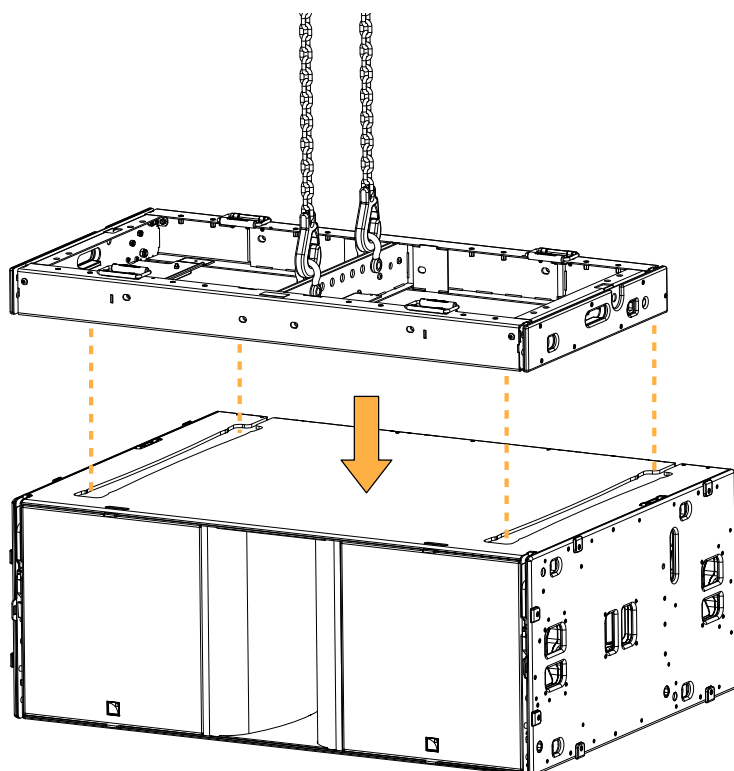

3. Pull on the front latches and rotate the front rigging arms of the enclosure.  
The latches of CS1-BUMP slide out slightly and come back into their positions.

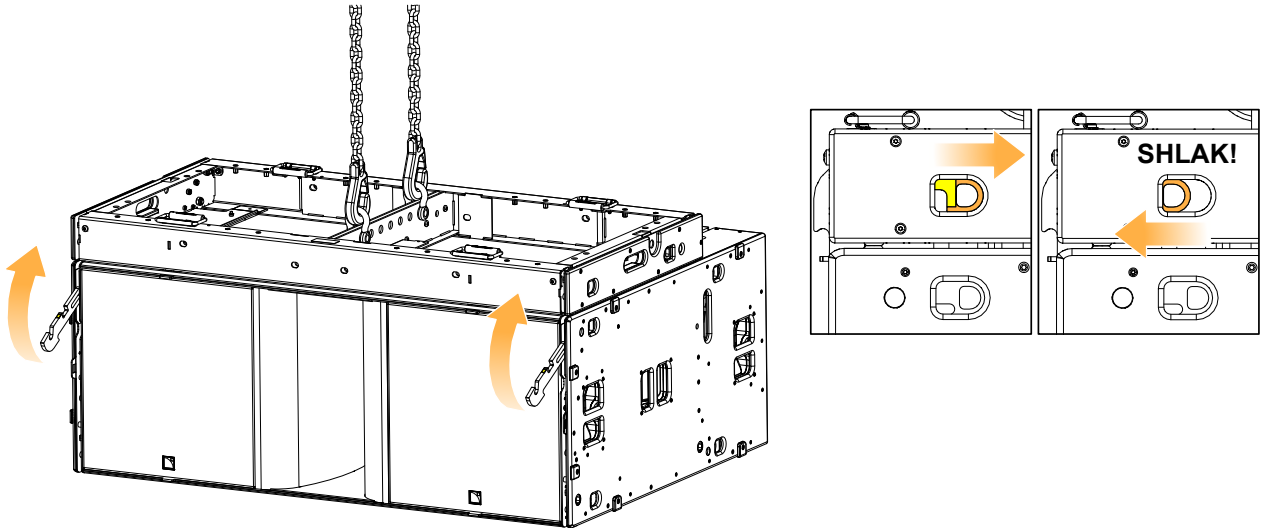

4. Press the front buttons on both sides of the enclosure to activate the automatic locking system.  
The latches retract when the button is pushed (no yellow label visible).

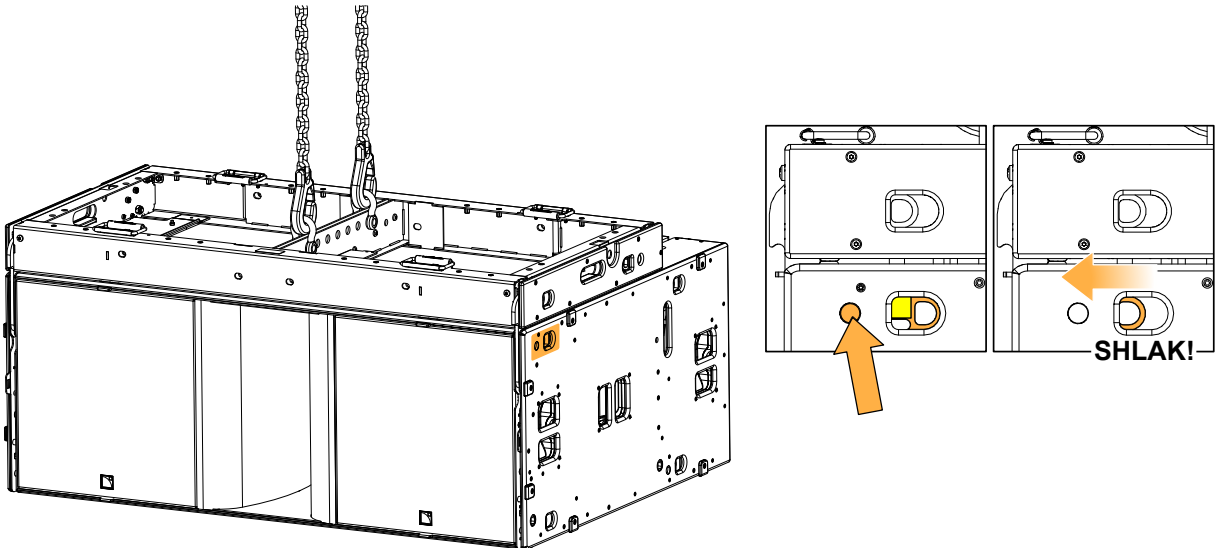

5. If necessary, pull on the rear latches of CS1-BUMP to deactivate the locking system.

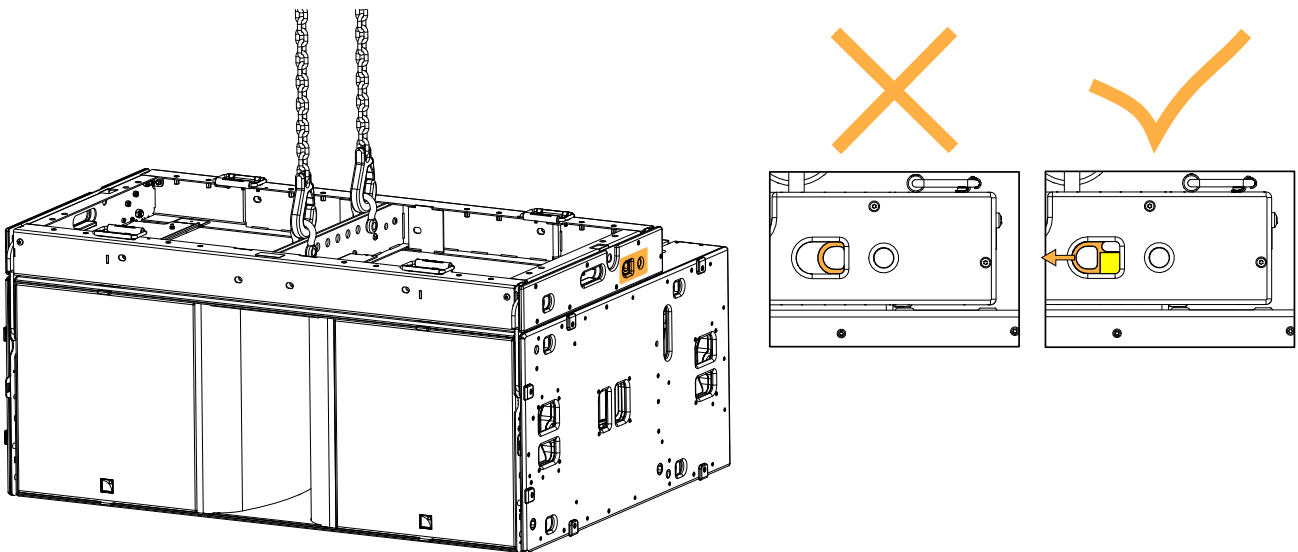

6. Pull on the rear latches of the enclosure while sliding up the rear rigging arms.  
Release the latches to lock the rigging arms in position.

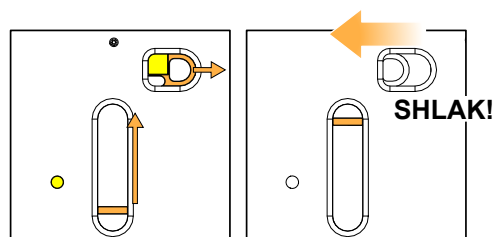
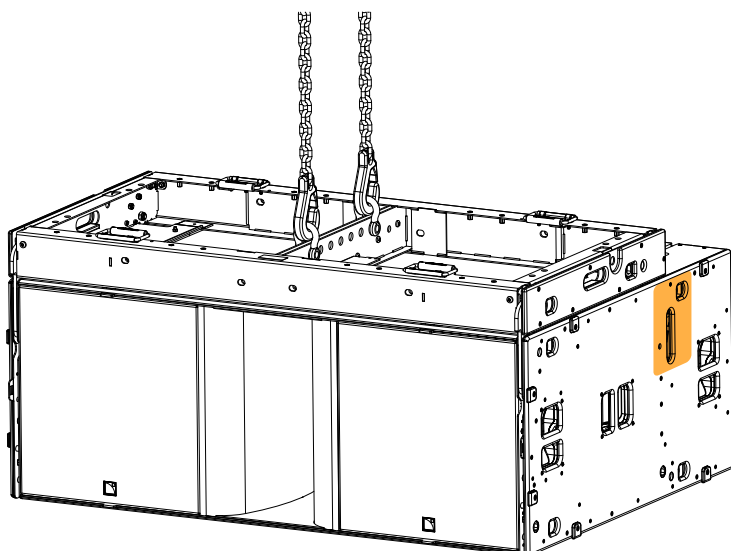

7. Press the buttons on both sides of CS1-BUMP to activate the automatic locking system.  
The latches retract when the button is pushed (no yellow label visible).

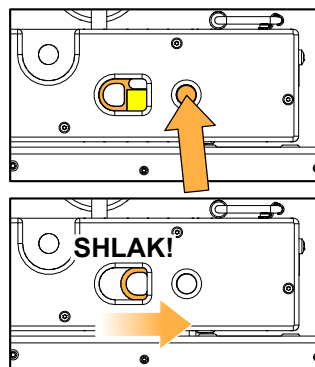
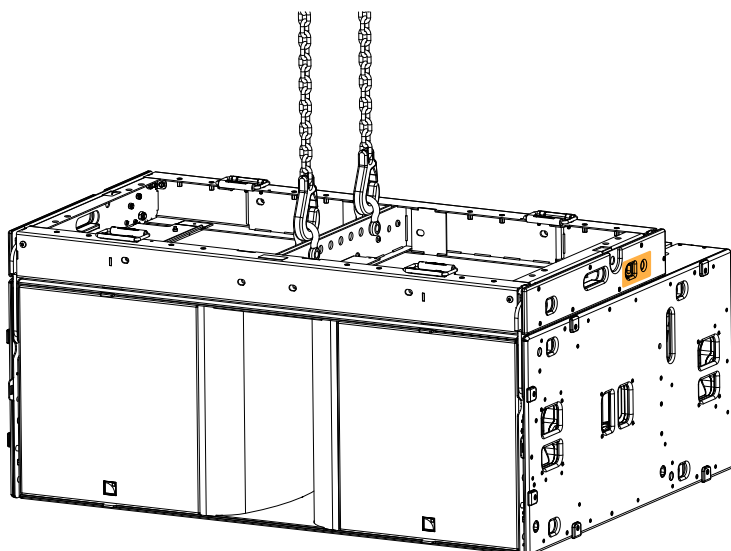

8. Raise the enclosure.
9. Position another enclosure below the first one.



**Risk of crushing injury**

Always use the handles to guide the upper enclosure.

- Lower the enclosure until the ground runners meet the matching tracks of the bottom enclosure.

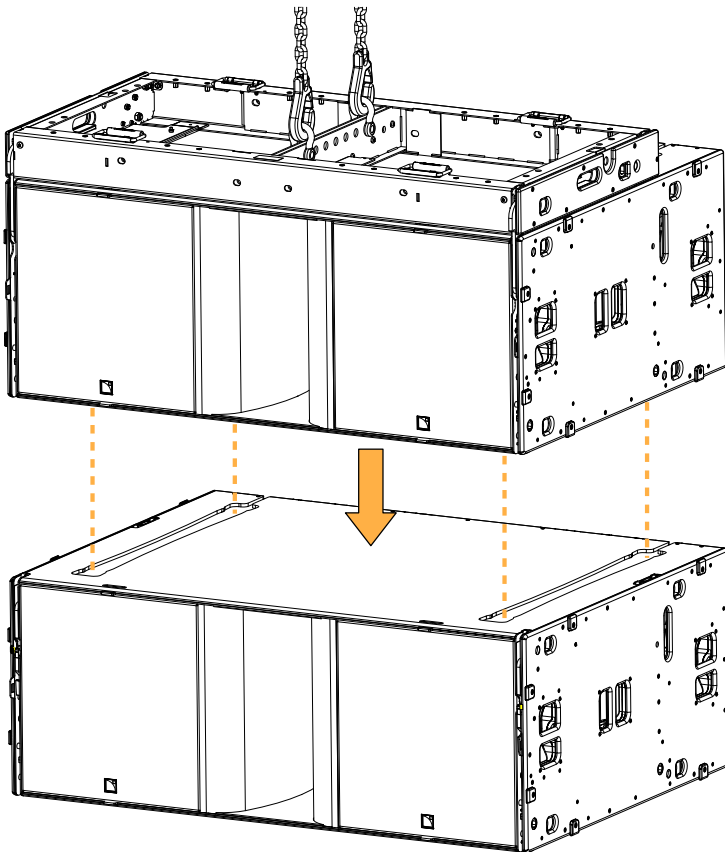

- Pull on the front latches and rotate the front rigging arms of the bottom enclosure. The latches of the top enclosure slide out slightly and come back into their positions.

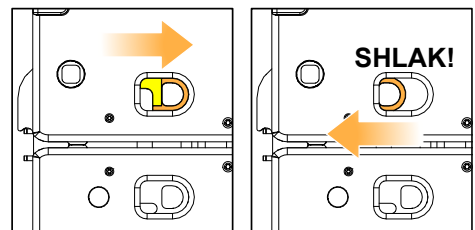
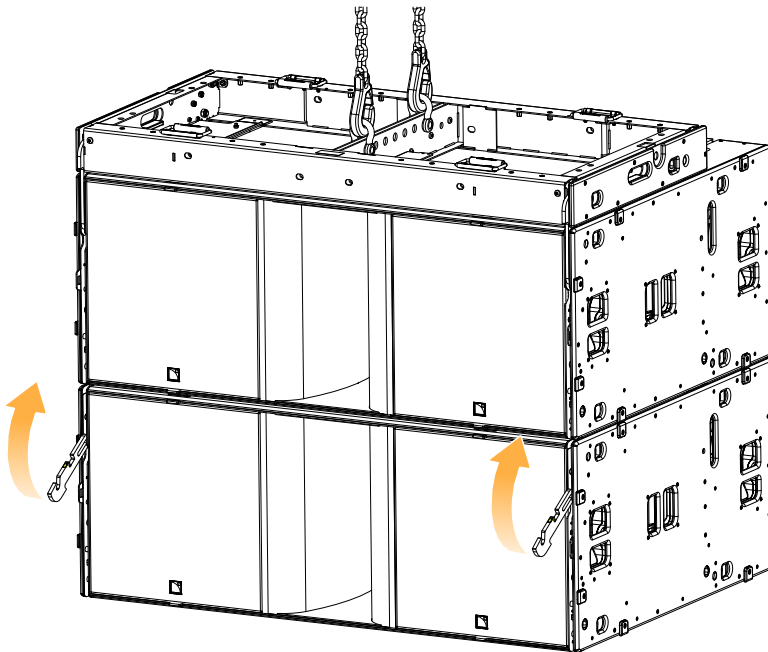

12. Press the buttons on both sides of the bottom enclosure to activate the automatic locking system.

The latches retract when the button is pushed (no yellow label visible).

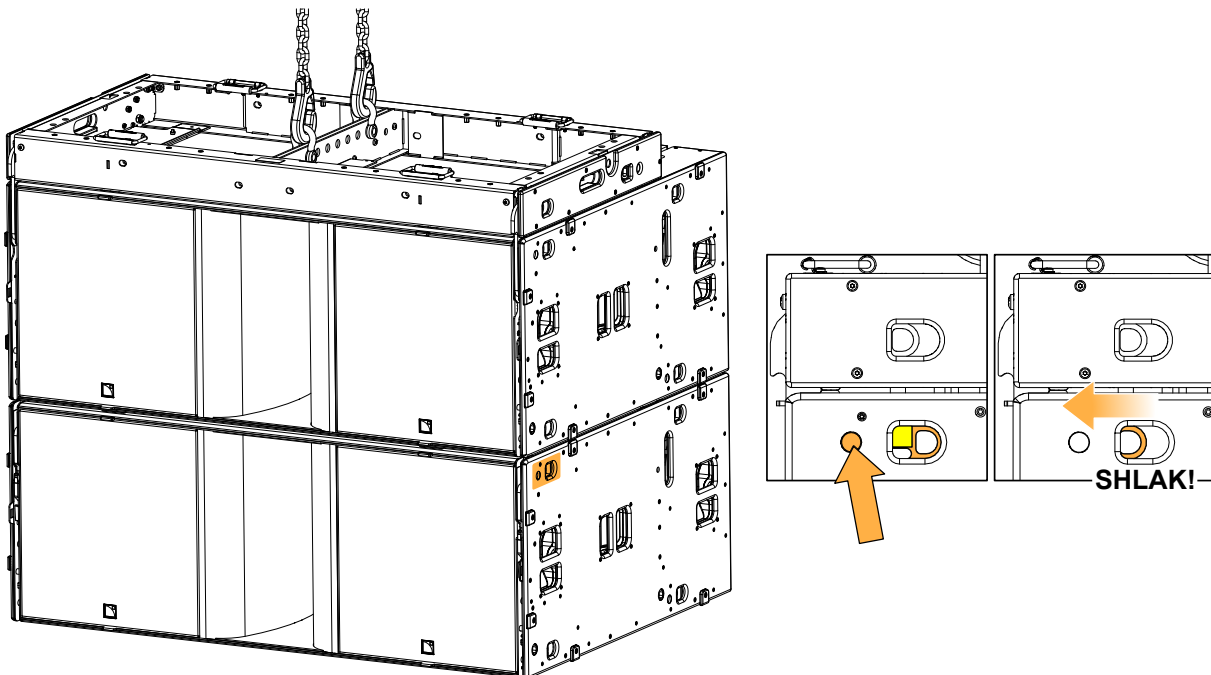

13. If necessary, pull on the rear latches of the top enclosure to deactivate the locking system.

The latches retract when the button is pushed (no yellow label visible).

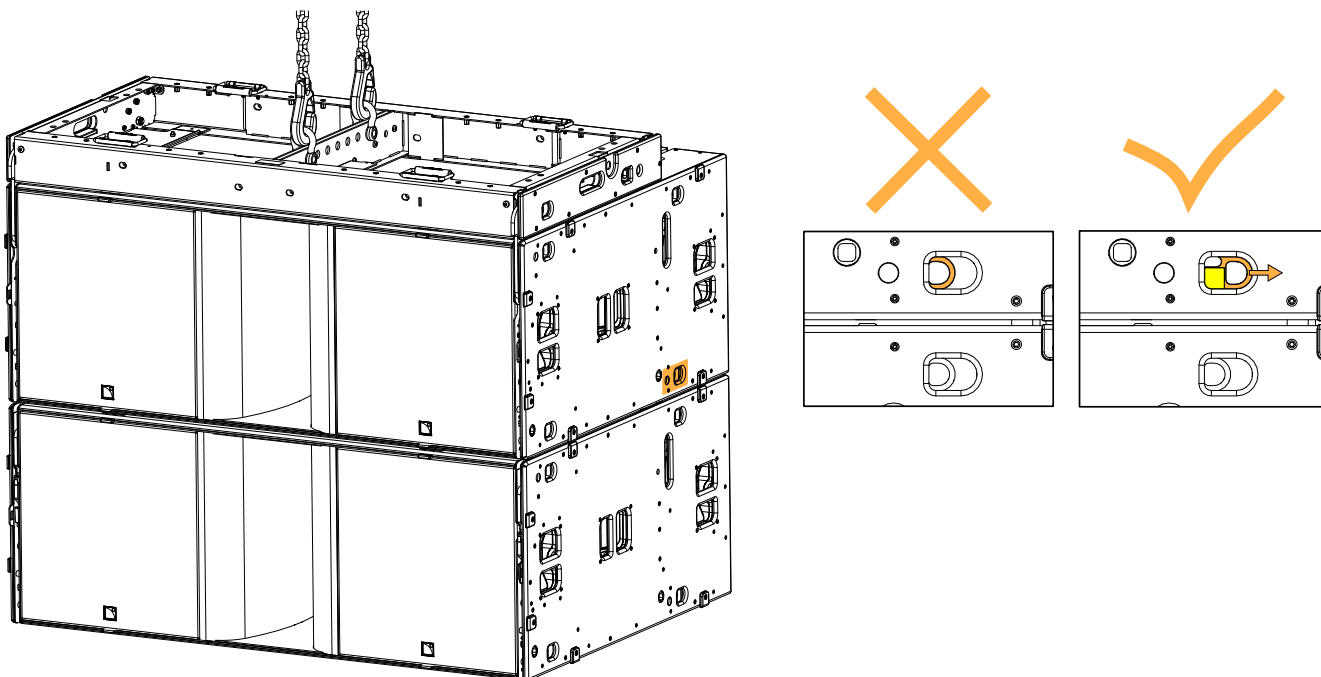

14. Pull on the rear latches of the bottom enclosure while sliding up the rear rigging arms.

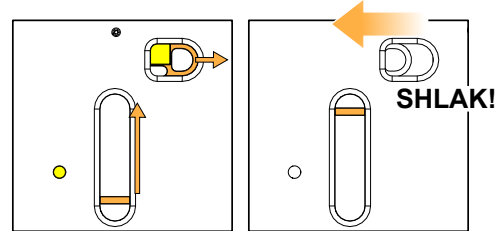
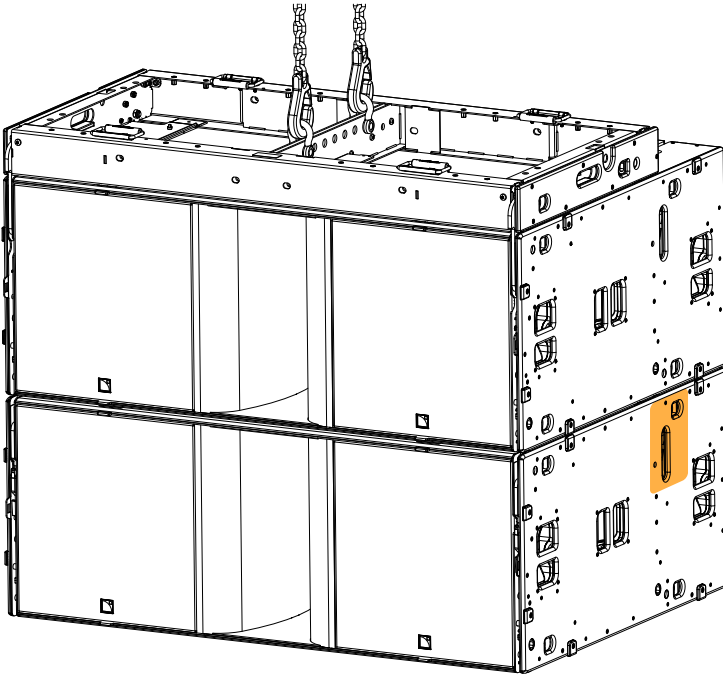

15. Press the buttons on both sides of the top enclosure to activate the automatic locking system.

The latches retract when the button is pushed (no yellow label visible).

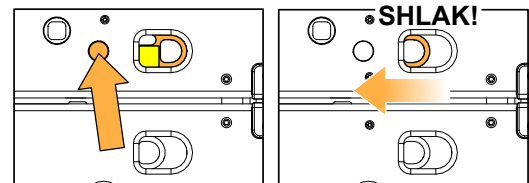
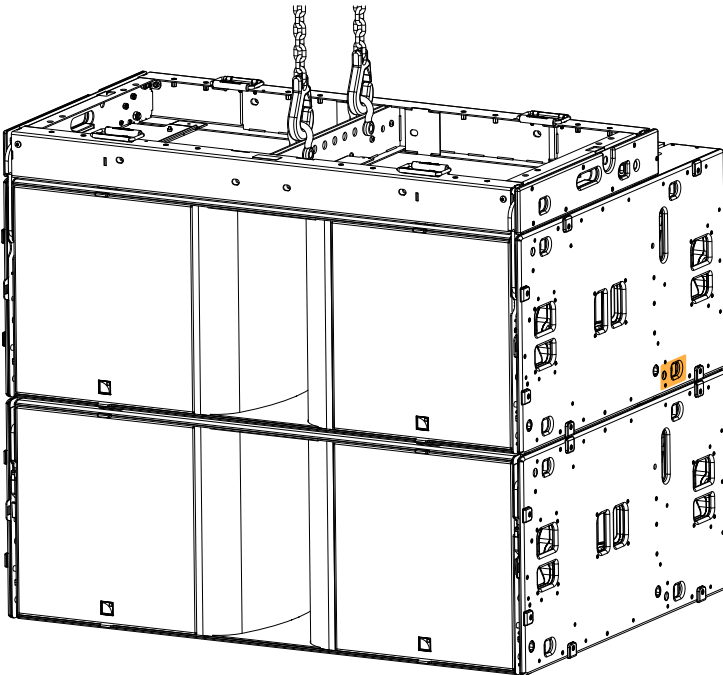

16. Repeat the procedure until the stack is complete.



**A maximum of 4 CS1 can be stacked on CS1-CHARIOT.**

Refer to [Mechanical safety](#) (p.35).

17. Slightly raise the assembly.  
 18. Position CS1-CHARIOT underneath the assembly.  
 19. Carefully lower the assembly until the bottom enclosure rests in CS1-CHARIOT.

20. Secure CS1-CHARIOT to the bottom enclosure.  
Push to engage the latch.

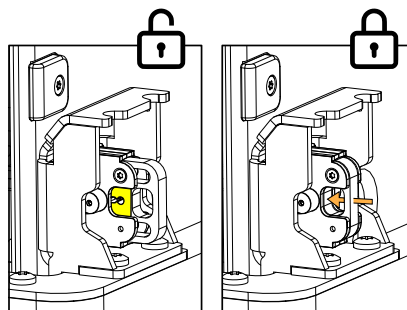
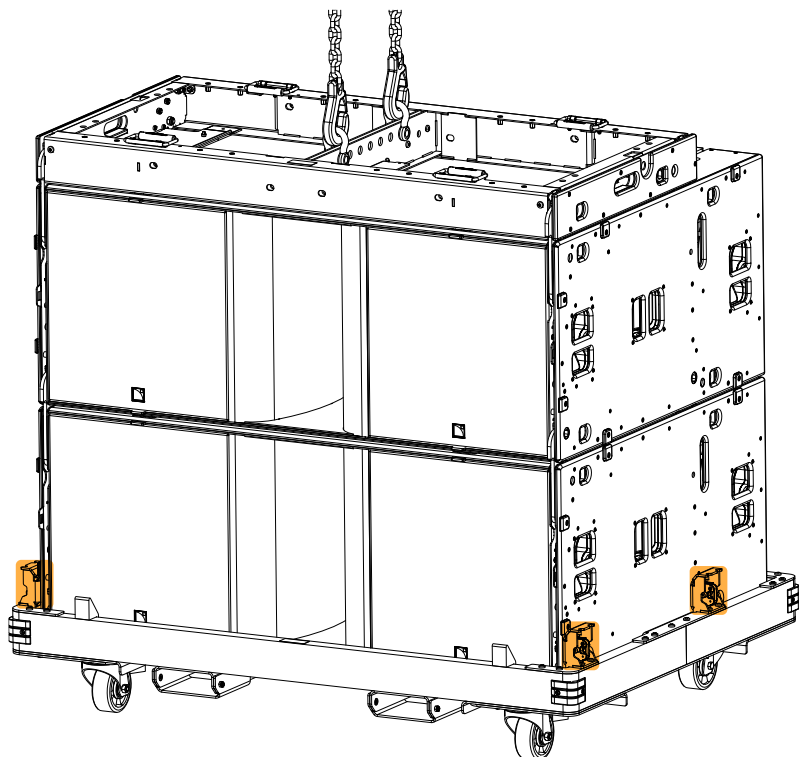

21. Remove CS1-BUMP:  
a) Pull the rear latches to deactivate the locking system.

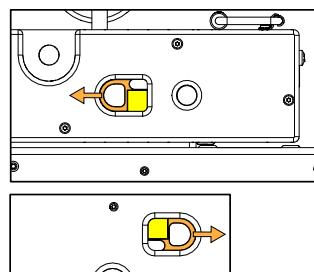
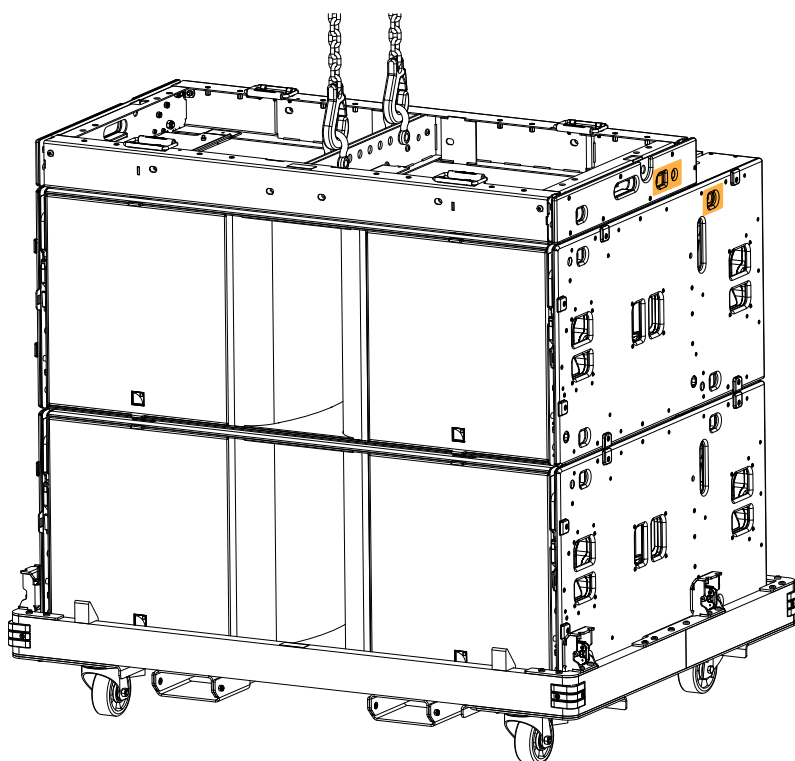

b) Slide down the rear rigging arms.

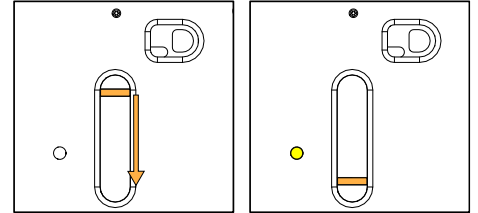
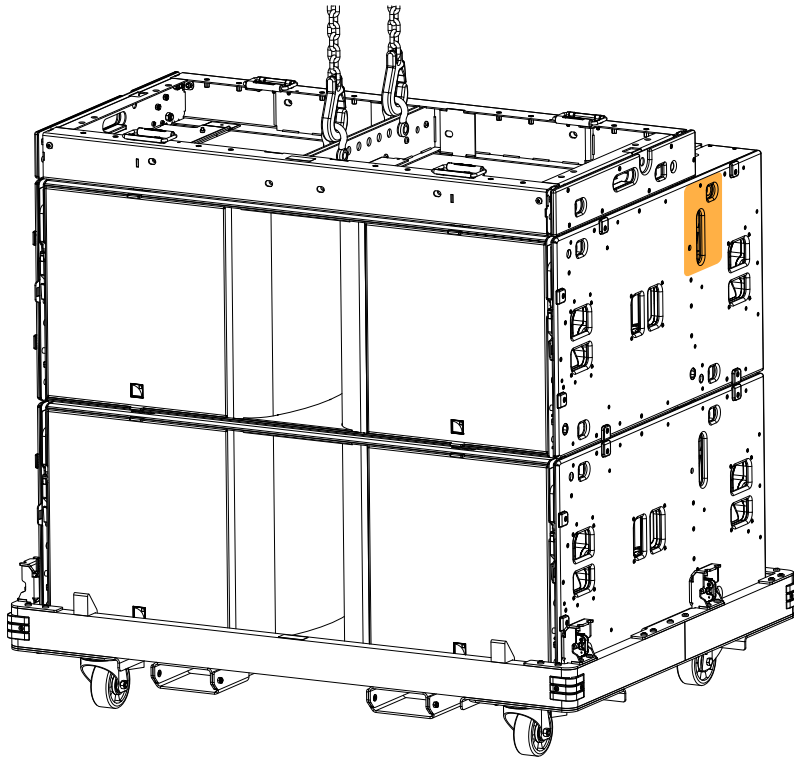

c) Pull the front latches to deactivate the locking system.

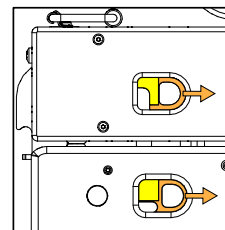
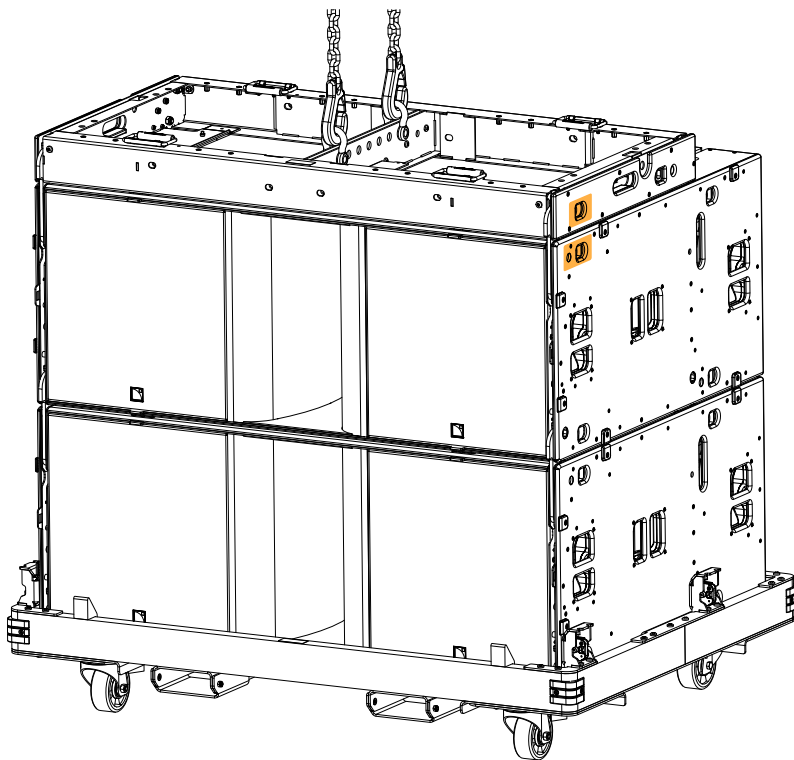

d) Remove the front rigging arms.

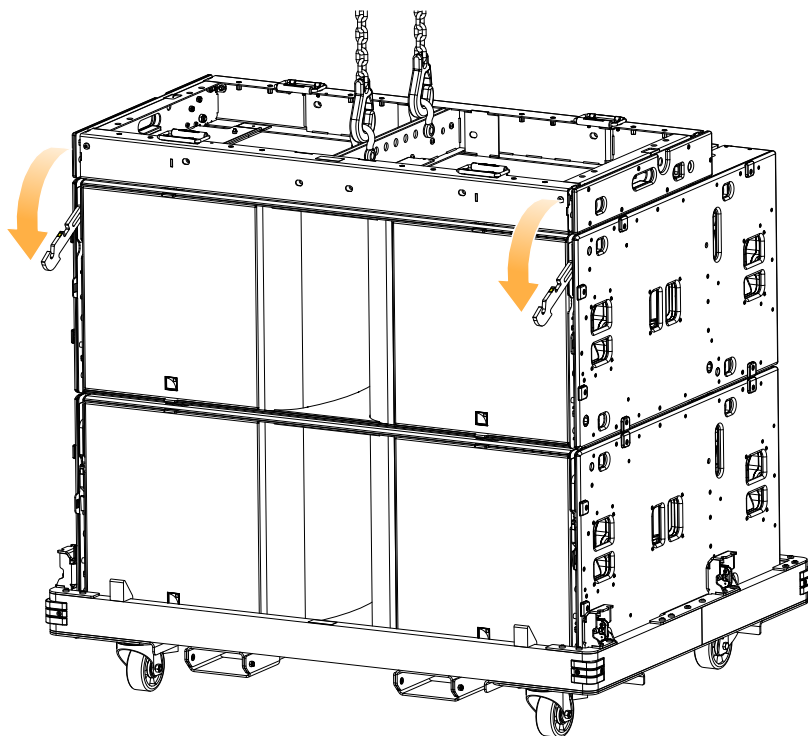

22. Slightly raise CS1-BUMP.



**Risk of falling and crushing injury**

Always guide and move the stack with its sides facing the transportation direction.

23. Position the stack at its final position.



**Final check**

Visually check that no yellow labels are visible.

## Connection to LA amplified controllers

**!** Refer to the **Amplification reference** technical bulletin for the latest information on compatibility with amplified controllers and cabling schemes for all enclosure types.

### Enclosure drive capacity per amplified controller

	LA7.16(i)	LA12X
	per output / total	
CS1	1/2	2/2

### Cabling schemes for CS1

Refer to the cabling schemes to connect the enclosures to different types of output configurations.

#### 4-channel CA-COM output

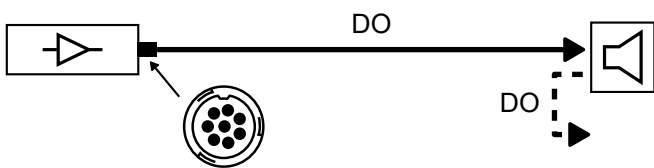

#### 16-channel SC32 output

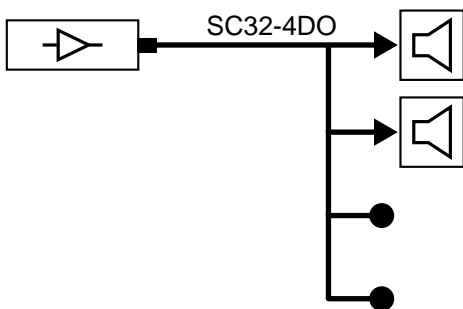

#### LA7.16i terminal block output

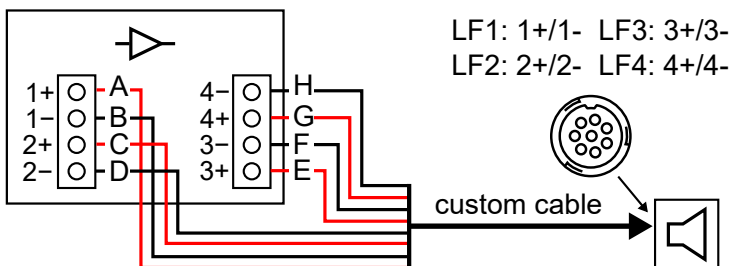

## Corrective maintenance

### Tools and consumables

---

Before performing maintenance on this product, make sure all the tools listed are available. References are given for FACOM® products in this table. Other manufacturers can be used.

<b>name</b>	<b>reference</b>	<b>distributor</b>
torque screwdriver (0.5 - 2.5 N.m)*	A.402	FACOM
torque screwdriver (2 - 10 N.m)*	A.404	FACOM
set of 6-point 1/4" sockets*	RL.NANO1 / R.360NANO	FACOM
flat plastic tool	—	—



\* included in the L-Acoustics Maintenance Toolcase.

### Maintenance Toolcase

The Maintenance Toolcase is a carry-on suitcase that includes all the tools required to perform maintenance on L-Acoustics products. This toolcase is aimed at Certified Providers.

The Maintenance Toolcase uses a Peli™ 1510 Protector case that features three pre-cut layers of foam to safely fit the tools. The Maintenance Toolcase includes tools manufactured by FACOM®, Fluke®, Tohnichi, ABUS, and Würth.



All third-party trademarks, registered trademarks, or product names are the property of their respective owners.

## Introduction

This section contains the following maintenance procedures:

- [D/R - Front grill](#) (p.75)
- [D/R - Fixing bars](#) (p.80)
- [D/R - SB speaker](#) (p.82)
- [D/R - Side panel](#) (p.84)
- [D/R - SC speaker](#) (p.85)

For advanced maintenance, contact your L-Acoustics representative.

## Exploded views

In order to operate, follow the order outlined here. Each assembly refers to the corresponding Disassembly/ Reassembly (D/R) procedure and the necessary repair kit (KR).

**! Heavy load: one CS1 weighs 180 kg (without rigging accessories or cables)**  
CS1 must be lifted by a lifting device.

**! Risk of injury due to hot surfaces**  
Wait for the loudspeaker to cool down before performing maintenance.

### Front view

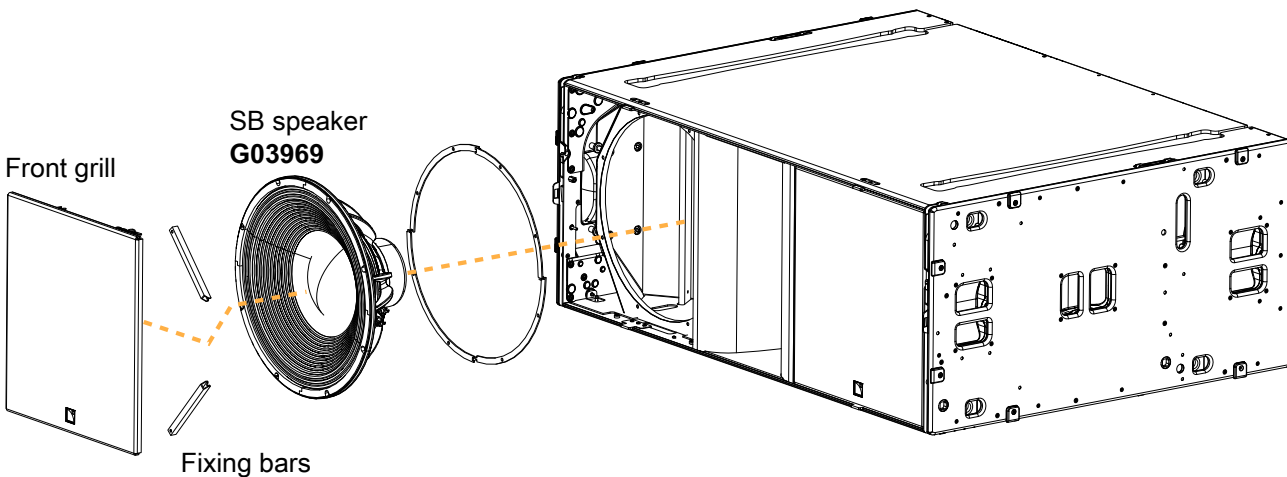

### Side view

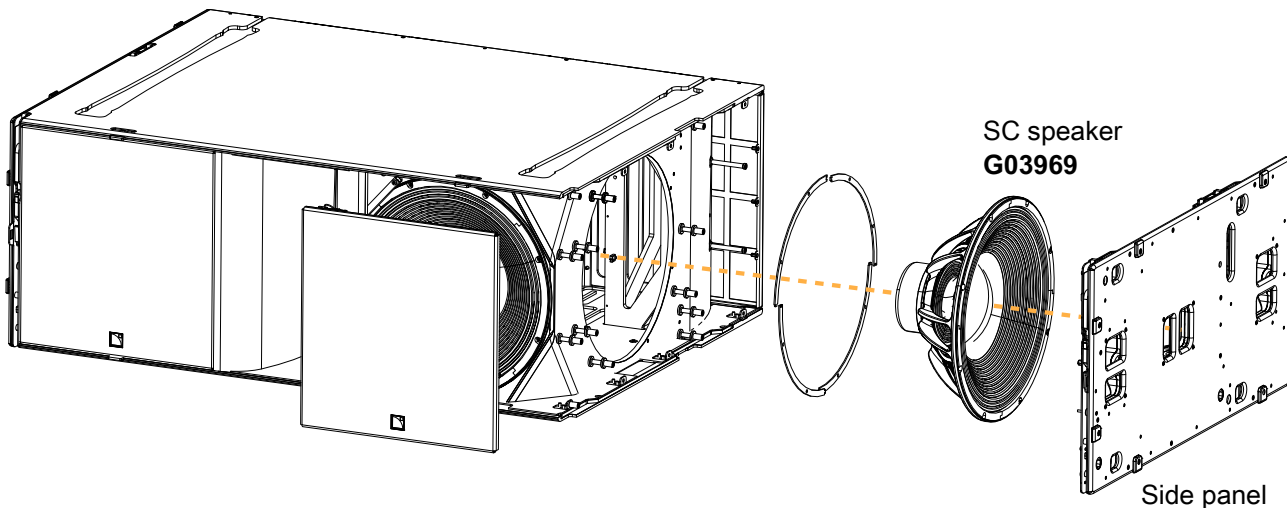

## Disassembly and Reassembly procedures

---

### D/R - Front grill

#### About this task



**Heavy load: one CS1 weighs 180 kg (without rigging accessories or cables)**

CS1 must be lifted by a lifting device.



**Risk of injury due to hot surfaces**

Wait for the loudspeaker to cool down before performing maintenance.

#### Tools

- torque screwdriver (0.5 - 2.5 N.m)
- torque screwdriver (2 - 10 N.m)
- T25 Torx bit
- T20 Torx bit
- flat tool

#### Repair kit

##### G03969 - KR loudspeaker 21" CS1



x1

S100052

M5×50 Torx

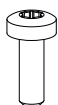

x1

S100039

M4×12 Torx



x1

S150

Ø 4 mm serrated lock washer

## Disassembly

### Procedure

1. Remove the screw securing the grill.  
Use the T25 Torx bit.

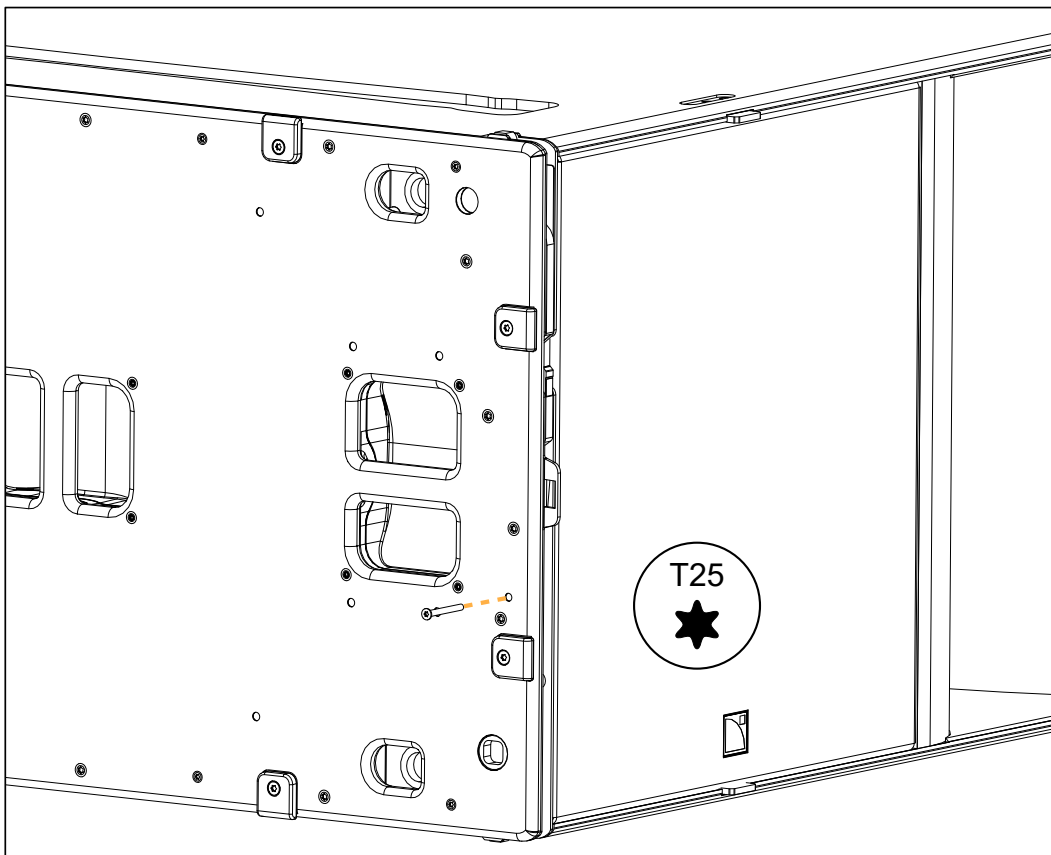

2. Use a flat tool as a lever to unlock the grill from the external side.

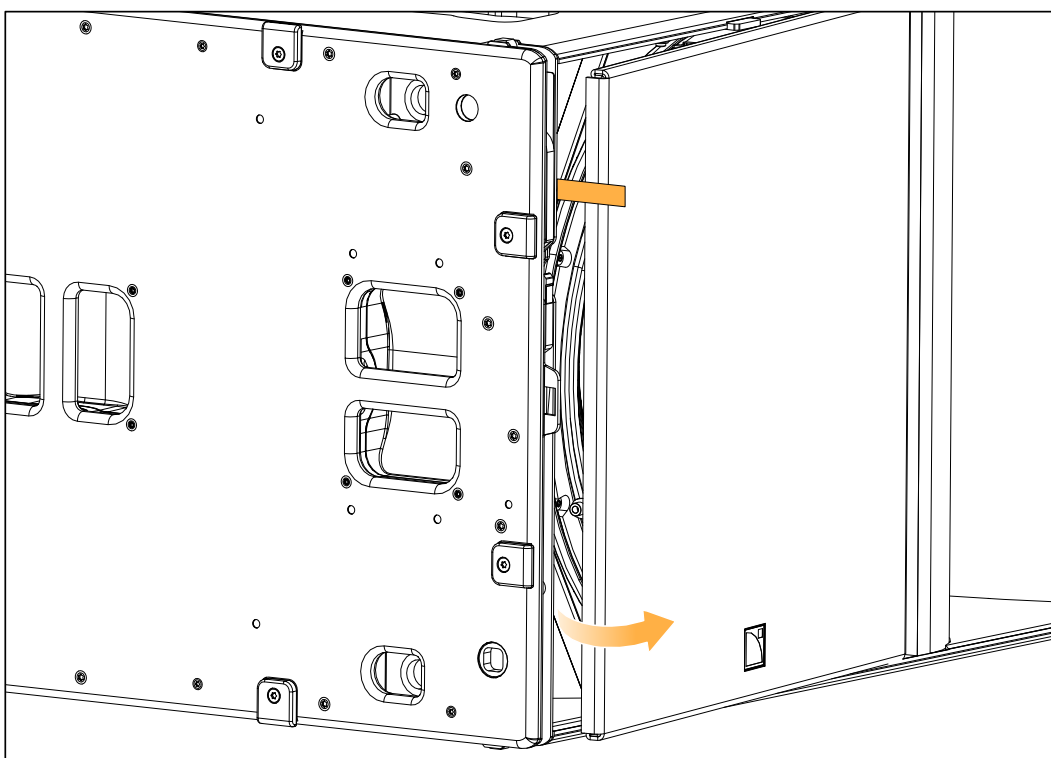

3. Pull the grill towards the external side to remove it.

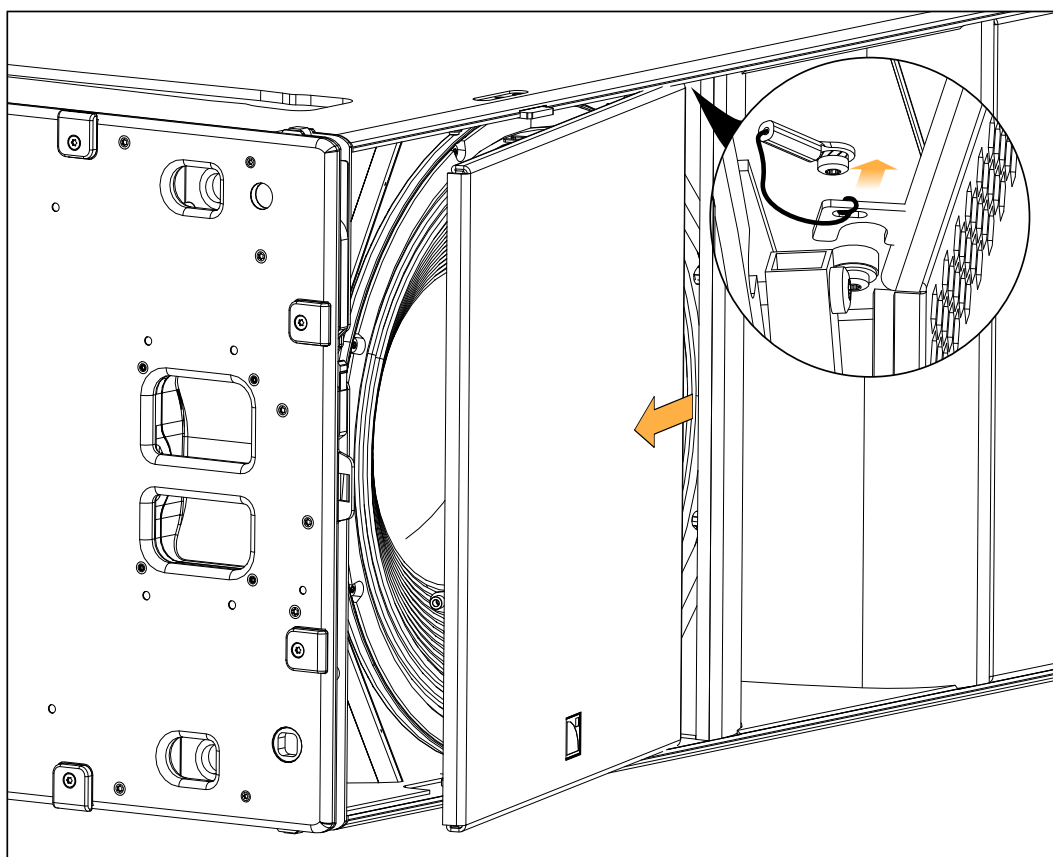

4. Remove the screw and the washer securing the grill tether.

Use the T20 Torx bit.

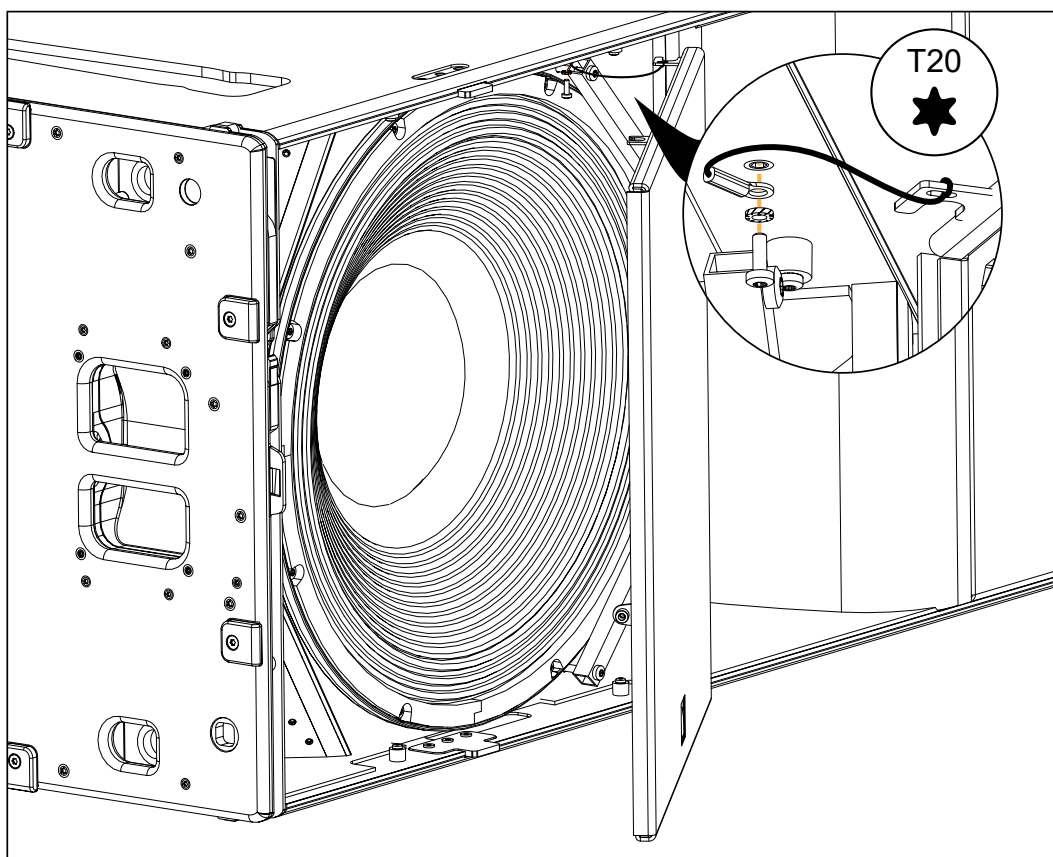

## Reassembly

### About this task

-  For safety reasons, always use the new screws and spare parts provided in the KR.  
 If no new screws are available, use blue threadlocker.

### Procedure

1. Tighten the screw and the washer securing the grill tether.

Use the torque screwdriver (0.5 - 2.5 N.m) with the T20 Torx bit. Set the torque to 1 N.m.

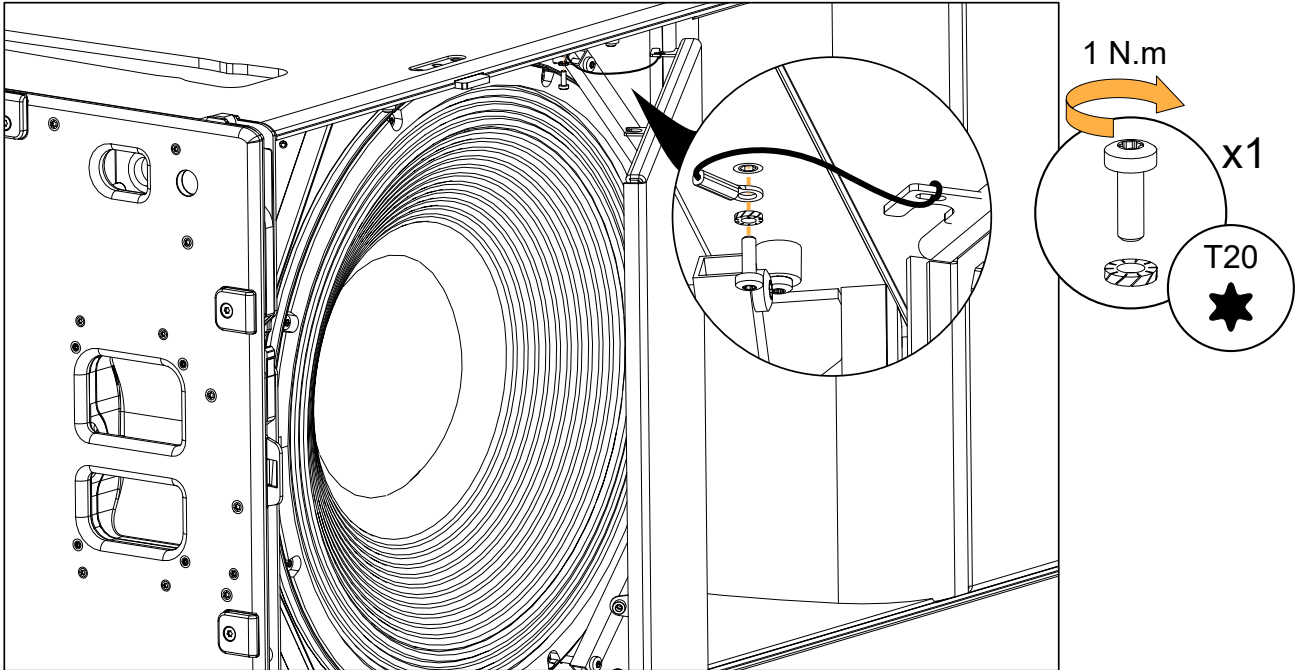

2. Slide the grill inside the enclosure to attach it to the stud.

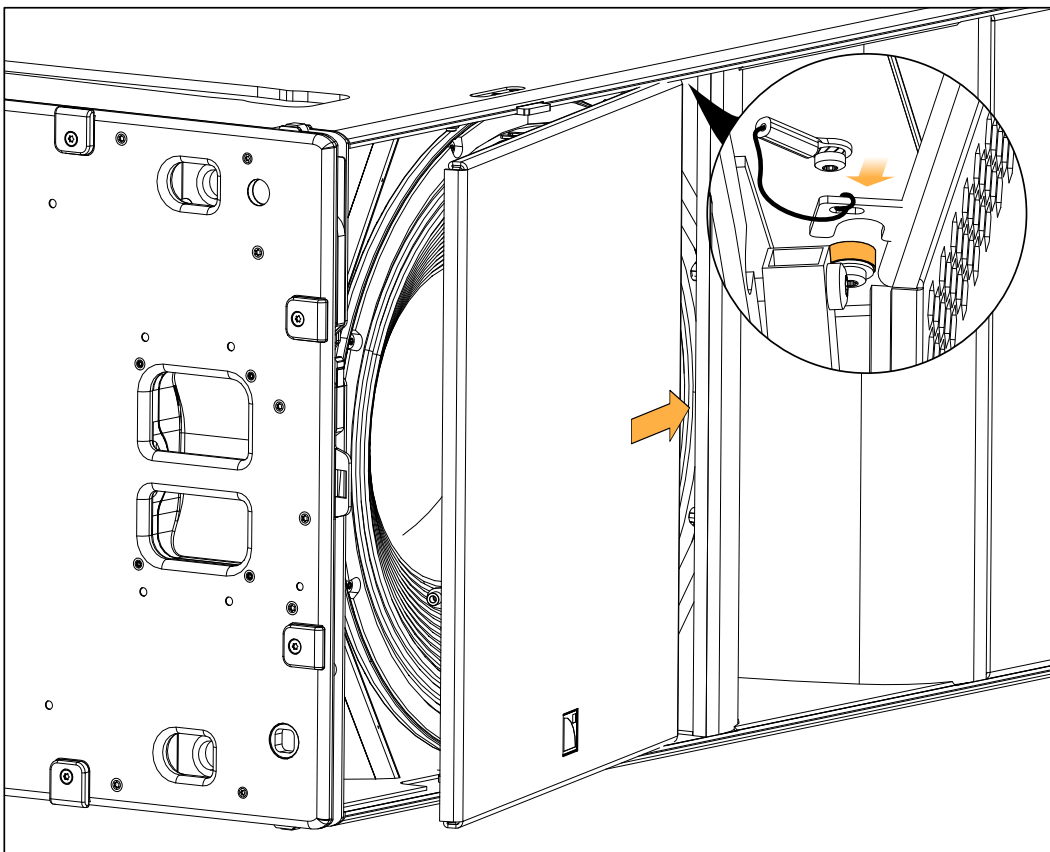

3. Push the grill into place.

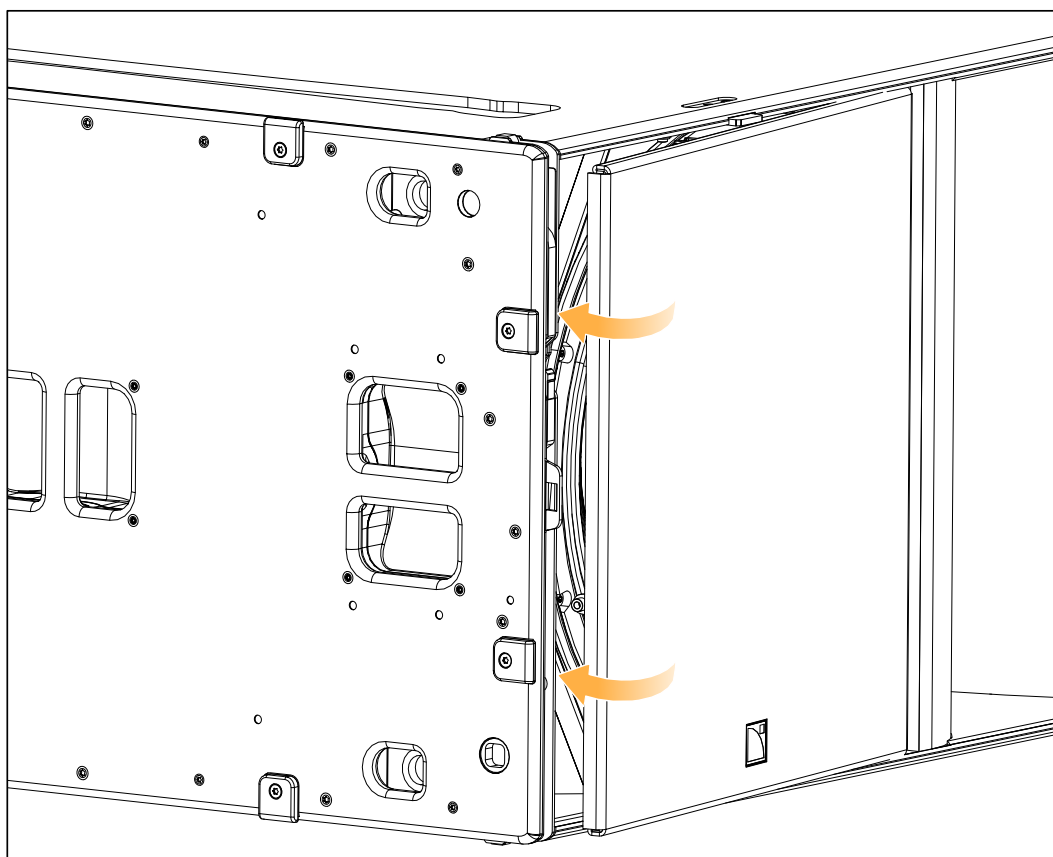

4. Tighten the screw securing the grill.

Use the torque screwdriver (2 - 10 N.m) with the T25 Torx bit.

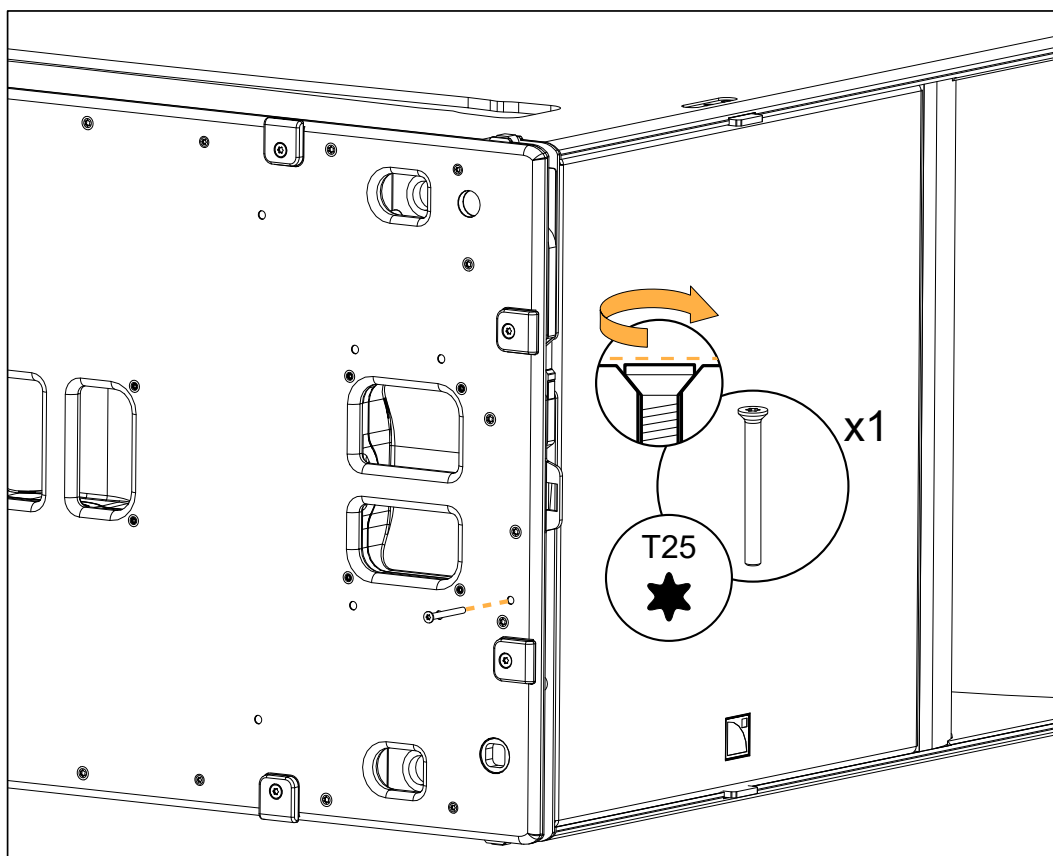

## D/R - Fixing bars

### About this task



**Heavy load: one CS1 weighs 180 kg (without rigging accessories or cables)**

CS1 must be lifted by a lifting device.



**Risk of injury due to hot surfaces**

Wait for the loudspeaker to cool down before performing maintenance.

### Tools

- torque screwdriver (2 - 10 N.m)
- T30 Torx bit

### Repair kit

#### G03969

KR loudspeaker 21" CS1

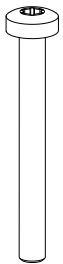

×2

S253

M6 × 55 Torx

### Prerequisite

Grill removed.

See [D/R - Front grill](#) (p.75).

**Exploded view**

For safety reasons, always use the new screws and spare parts provided in the KR.

If no new screws are available, use blue threadlocker.

For reassembly, slide the fixing bars under the vent panel to attach them to the studs, then secure them with the screws.

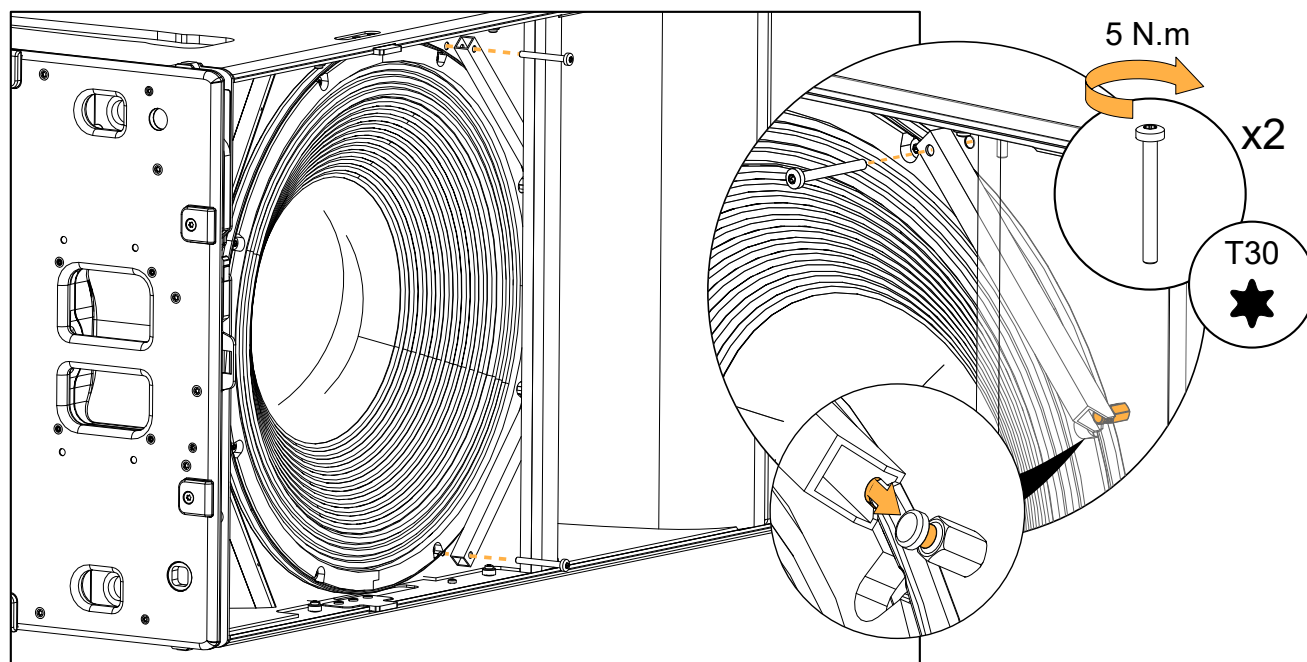

## D/R - SB speaker

### About this task



**Heavy load: one CS1 weighs 180 kg (without rigging accessories or cables)**

CS1 must be lifted by a lifting device.



**Risk of injury due to hot surfaces**

Wait for the loudspeaker to cool down before performing maintenance.

### Tools

- torque screwdriver (2 - 10 N.m)
- T30 Torx bit

### Repair kit

#### G03969

KR loudspeaker 21" CS1

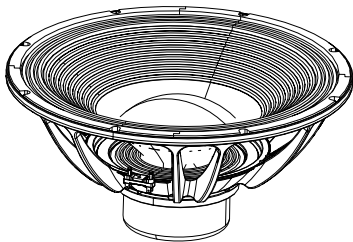

x1

18715

21" LF speaker - 8 Ω

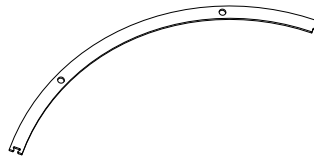

x4

102157

21" speaker gasket

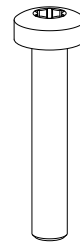

x8

S247

M6x35 Torx

### Prerequisite

Grill removed.

See [D/R - Front grill](#) (p.75).

Fixing bars removed.

See [D/R - Fixing bars](#) (p.80).

## Exploded views

**!** For safety reasons, always use the new screws and spare parts provided in the KR.  
If no new screws are available, use blue threadlocker.

**!** Gradually tighten the screws following a star pattern.

Tilt the speaker to remove it from the cabinet. Carefully disconnect the cables before removing the speaker.

Position the speaker with the connectors towards the external side of the enclosure.

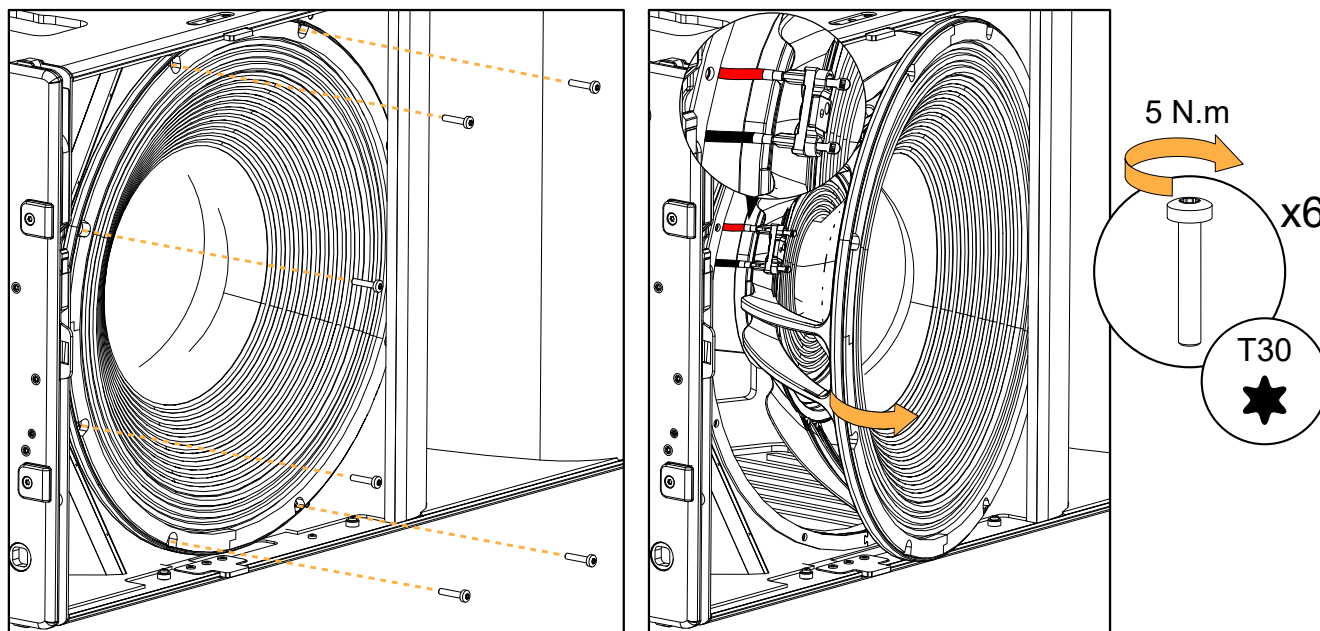

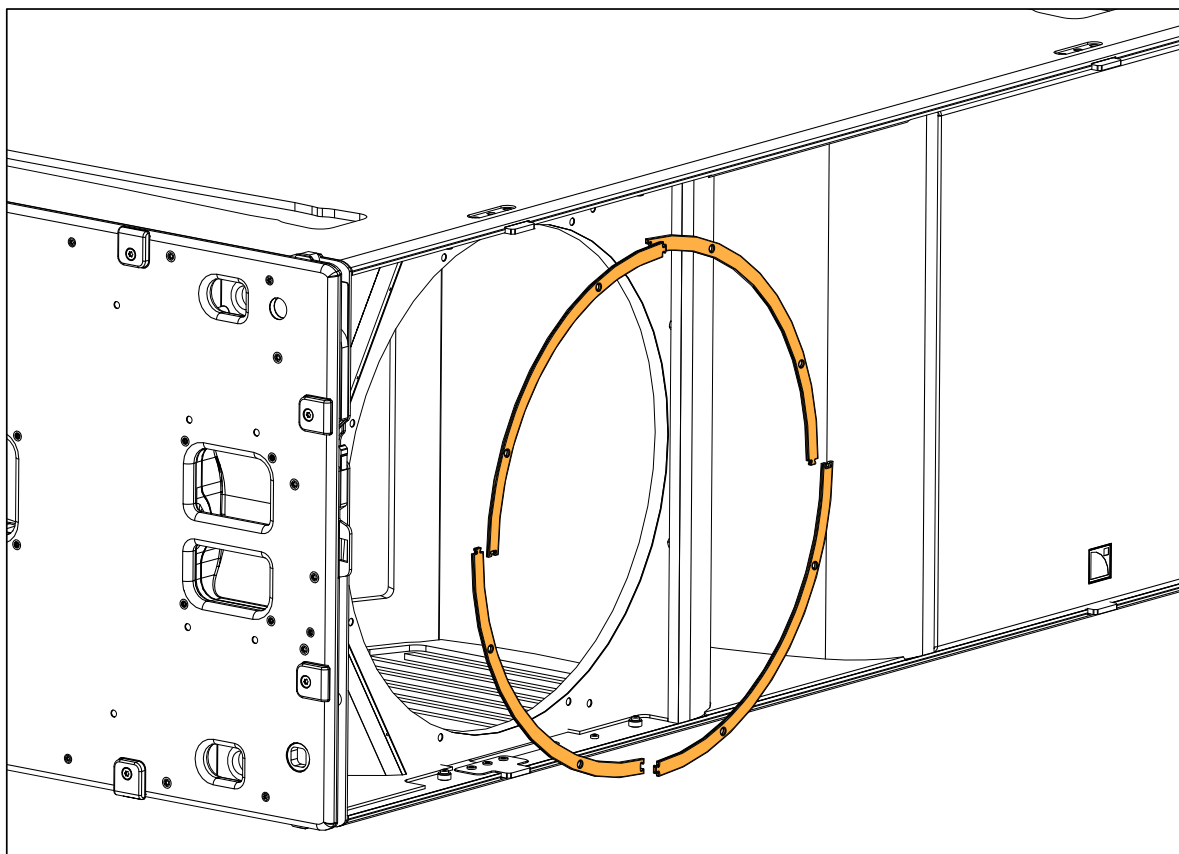

**i** If the speaker gasket is damaged, remove and replace it.



## D/R - Side panel

### About this task

-  **Heavy load: one CS1 weighs 180 kg (without rigging accessories or cables)**  
CS1 must be lifted by a lifting device.
-  **Risk of injury due to hot surfaces**  
Wait for the loudspeaker to cool down before performing maintenance.

### Tools

- torque screwdriver
- T25 Torx bit

### Repair kit

#### G03969

KR loudspeaker 21" CS1

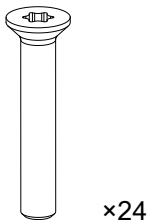

S100327

M5x30 Torx

### Prerequisite

Grill removed.

See [D/R - Front grill](#) (p.75).

### Exploded view

-  For safety reasons, always use the new screws and spare parts provided in the KR.  
If no new screws are available, use blue threadlocker.

The side panel is held by 24 screws (circled in the illustration). **Do not remove the screws that are crossed out.**

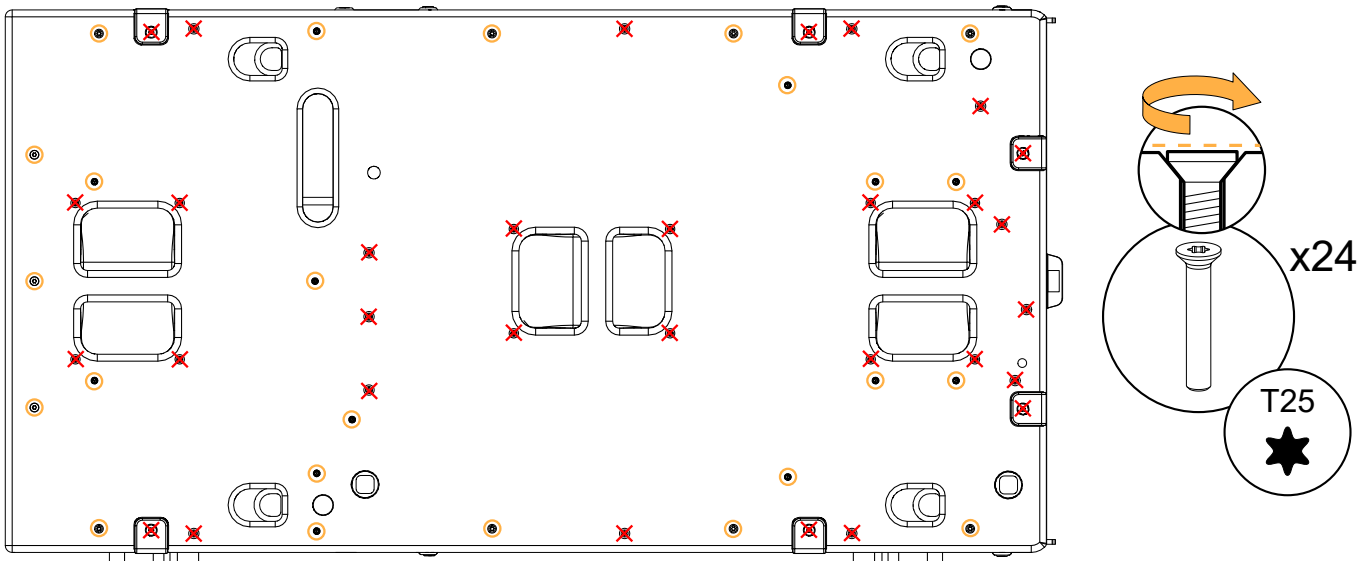

left-hand side panel (panels are symmetrical)

## D/R - SC speaker

### About this task



**Heavy load: one CS1 weighs 180 kg (without rigging accessories or cables)**

CS1 must be lifted by a lifting device.



**Risk of injury due to hot surfaces**

Wait for the loudspeaker to cool down before performing maintenance.

### Tools

- torque screwdriver (2 - 10 N.m)
- T30 Torx bit

### Repair kit

#### G03969

KR loudspeaker 21" CS1

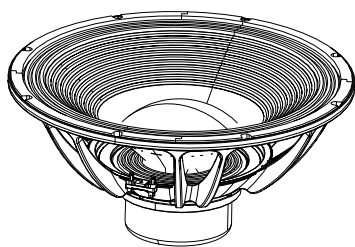

x1

18715

21" LF speaker - 8 Ω

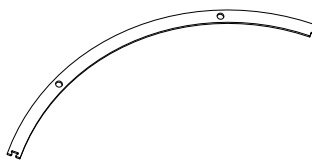

x4

102157

21" speaker gasket



x8

S247

M6×35 Torx

### Prerequisite

Grill removed.

See [D/R - Front grill](#) (p.75).

Side panel removed.

See [D/R - Side panel](#) (p.84).

### Exploded views

- ❗ For safety reasons, always use the new screws and spare parts provided in the KR. If no new screws are available, use blue threadlocker.
- ❗ Gradually tighten the screws following a star pattern.

Carefully disconnect the cables before removing the speaker.

Position the speaker with the connectors towards the front of the enclosure.

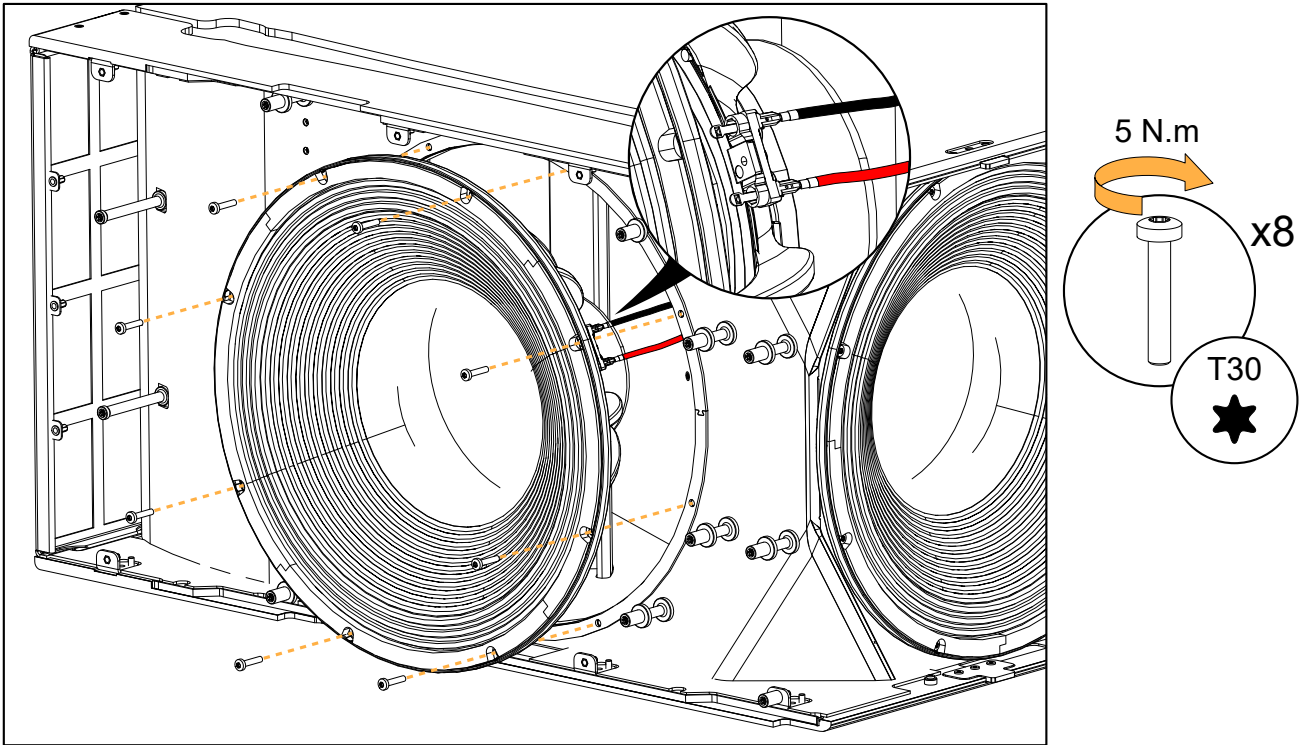

- i** If the speaker gasket is damaged, remove and replace it.

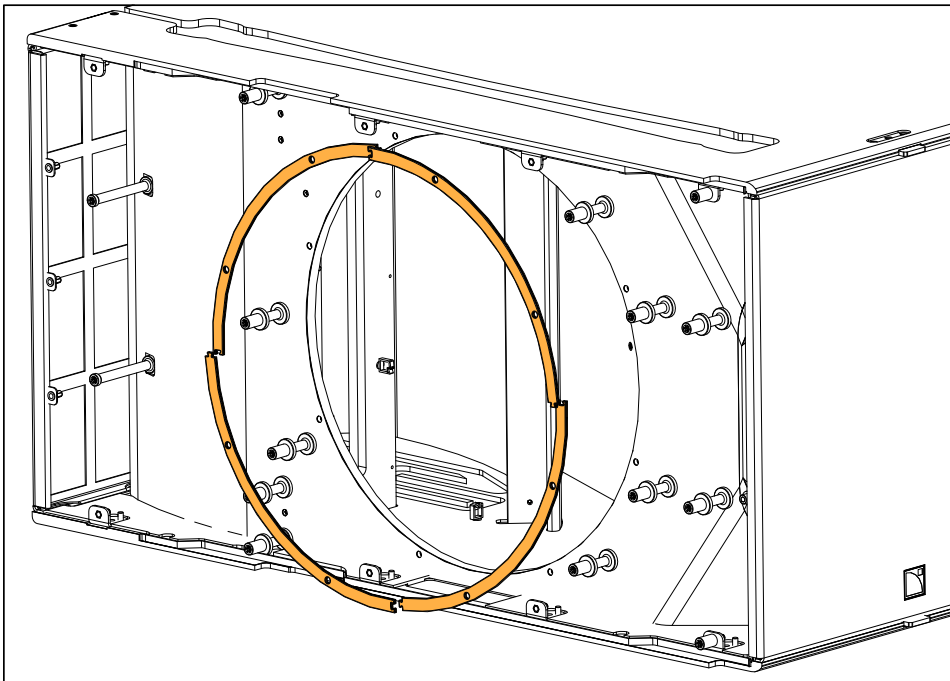

## Specifications

### CS1 specifications

---

<b>Description</b>	Cardioid subwoofer 4 × 21" amplified by LA12X / LA7.16 / LA7.16i
<b>Low frequency limit (-10 dB)</b>	25 Hz ([CS1_60])
<b>Enclosure maximum SPL per amplified controller<sup>1</sup></b>	150 dB ([CS1_X])
<b>Nominal directivity (-6 dB)</b>	cardioid or supercardioid
<b>Transducers</b>	4 × 21" neodymium
<b>Acoustical load</b>	bass-reflex, L-Vents
<b>Nominal impedance</b>	8 Ω
<b>Connectors</b>	IN: 8-point CA-COM
<b>Rigging and handling</b>	flush-fitting 4-point captive rigging system 6 handles 2 ground runners 8 side runners
<b>Weight (net)</b>	180 kg / 397 lb
<b>Cabinet</b>	premium grade Baltic beech and birch plywood
<b>Front</b>	coated steel grill acoustically neutral 3D fabric
<b>Rigging components</b>	high grade steel with anti-corrosion coating
<b>Finish</b>	dark grey brown Pantone 426 C
<b>IP</b>	IP55

<sup>1</sup> Peak level at 1 m under half space conditions using pink noise with crest factor 4 (preset specified in brackets).

### CS1 dimensions

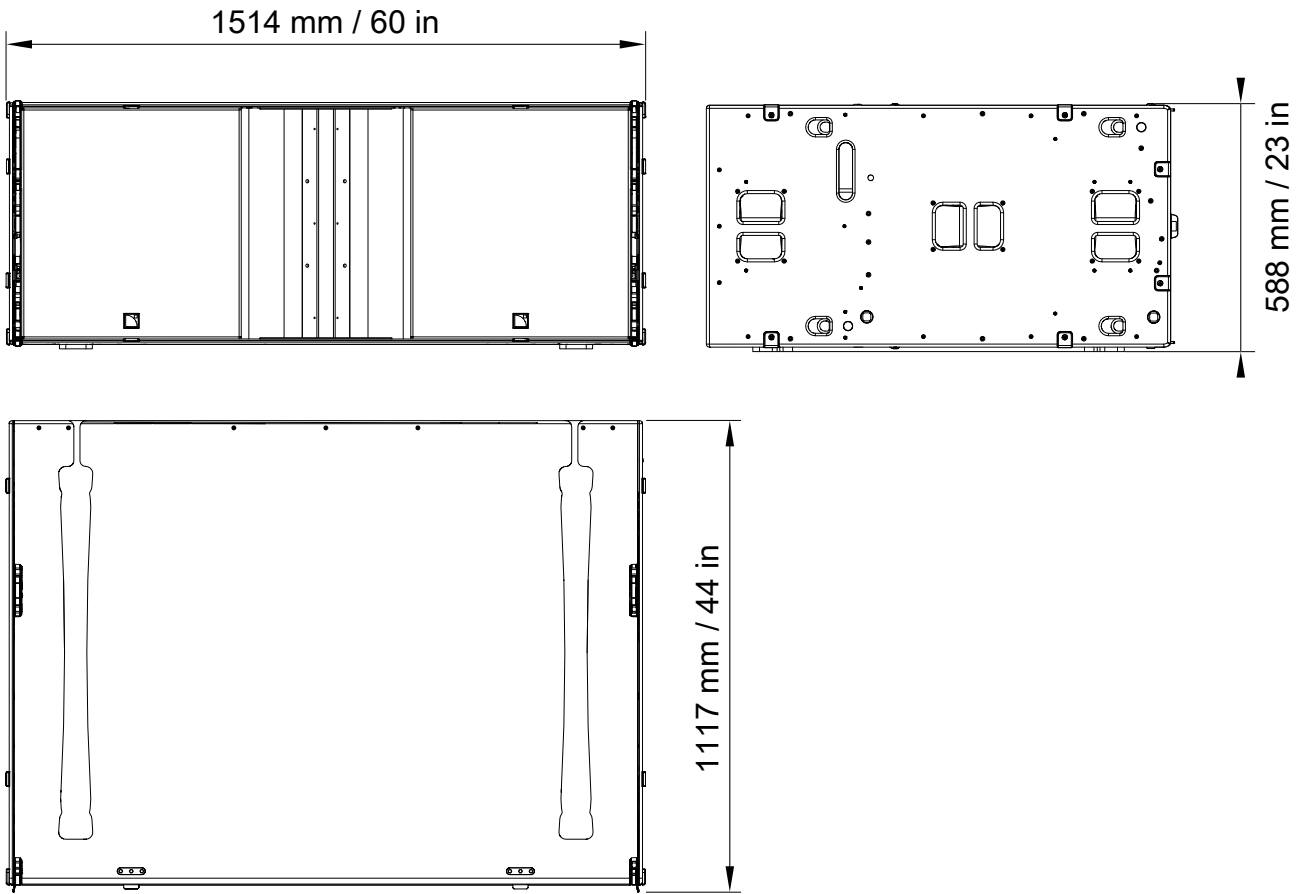

## CS1-BUMP specifications

---

<b>Description</b>	Flying frame for L1(D) and CS1 (incl. 1 extension sling + 1 laser adapter) 2 × Ø19 mm shackles WLL 3.25 t
<b>Weight (net)</b>	56 kg / 123 lb
<b>Material</b>	high grade steel with anti-corrosion coating

### CS1-BUMP dimensions

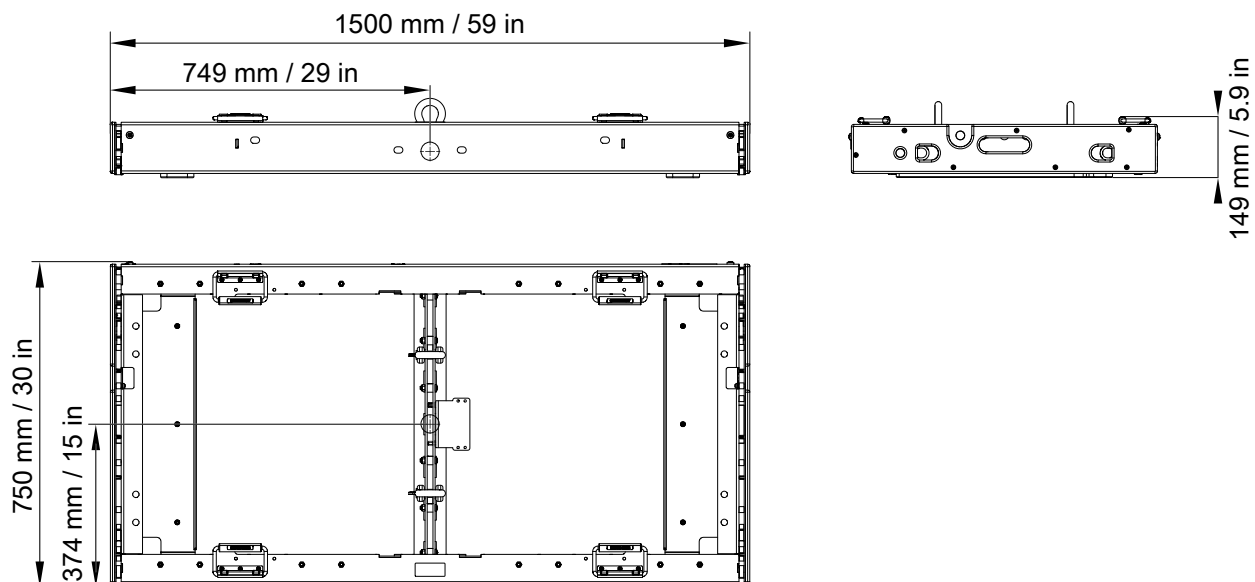

## CS1-BAR specifications

---

<b>Description</b>	Extension bar for CS1-BUMP and L1-BUMP 2 × Ø19 mm shackles WLL 3.25 t
<b>Weight (net)</b>	26 kg / 57 lb
<b>Material</b>	high grade steel with anti-corrosion coating

### CS1-BAR dimensions

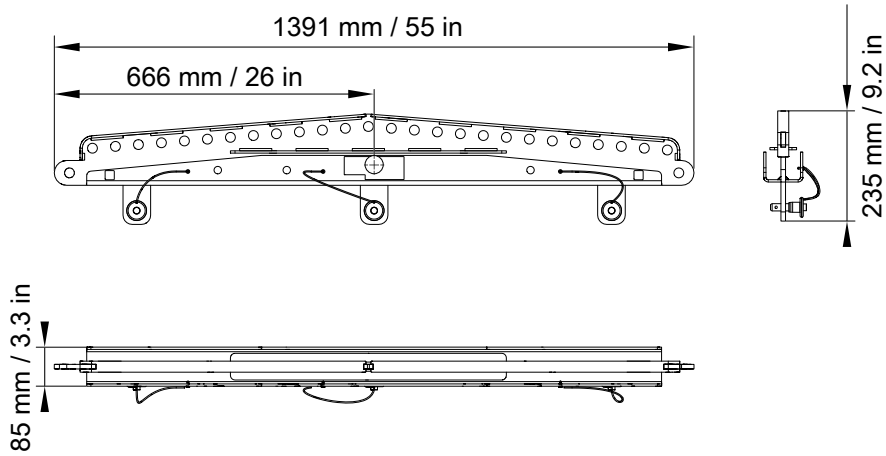

## L1-BUMP specifications

<b>Description</b>	Flying frame for L1(D) and CS1 (incl. L1CS1-RAKMOUNT, 1 extension sling and 1 laser adapter) 2 × Ø22 mm shackles WLL 4.75 t
<b>Weight (net)</b>	110 kg / 243 lb
<b>Material</b>	high grade steel with anti-corrosion coating

### L1-BUMP dimensions

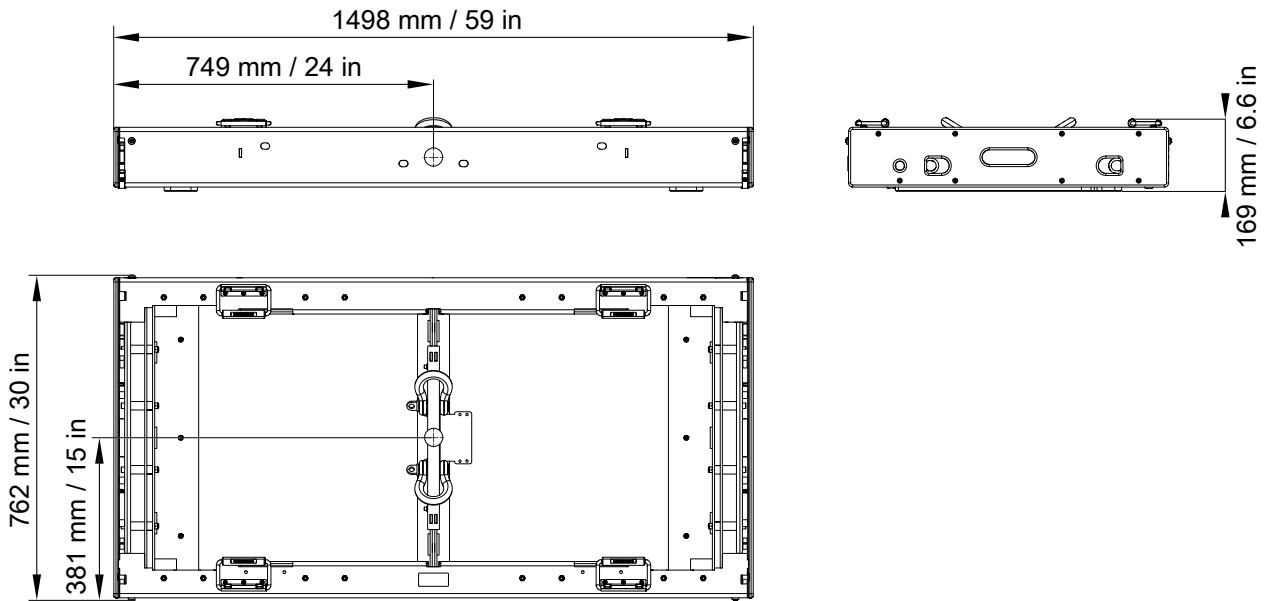

### With L1CS1-RAKMOUNT secured on L1-BUMP

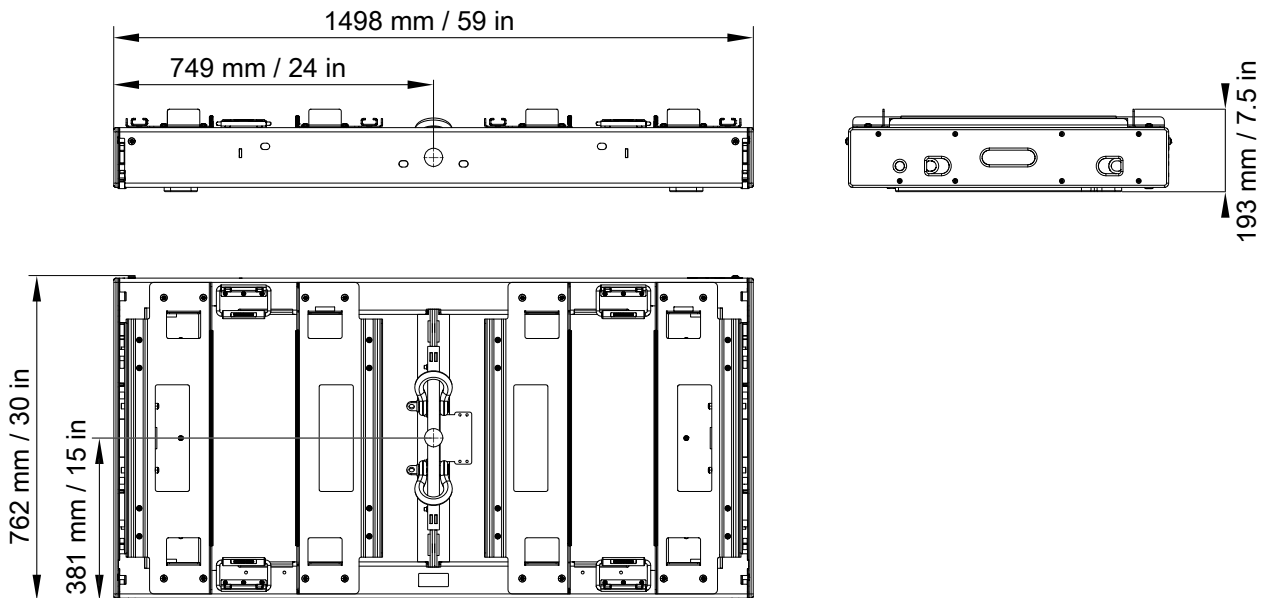

See [L1CS1-RACKMOUNT specifications](#) (p.93)

## L1-BAR specifications

---

<b>Description</b>	Extension bar for L1-BUMP 2 × Ø22 mm shackles WLL 4.75 t
<b>Weight (net)</b>	33 kg / 73 lb
<b>Material</b>	high grade steel with anti-corrosion coating

### L1-BAR dimensions

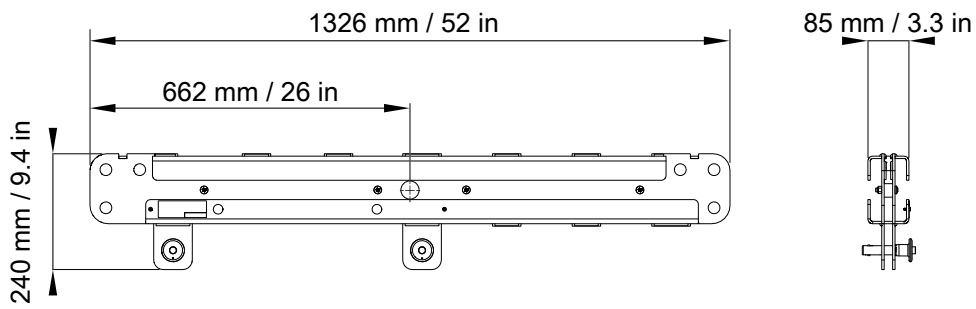

## L1CS1-RAKMOUNT specifications

---

<b>Description</b>	4 mounting cradles for LA-RAK III (incl. rack stabilizer)
<b>Weight (net)</b>	22 kg / 49 lb
<b>Material</b>	high grade steel with anti-corrosion coating

### L1CS1-RAKMOUNT dimensions

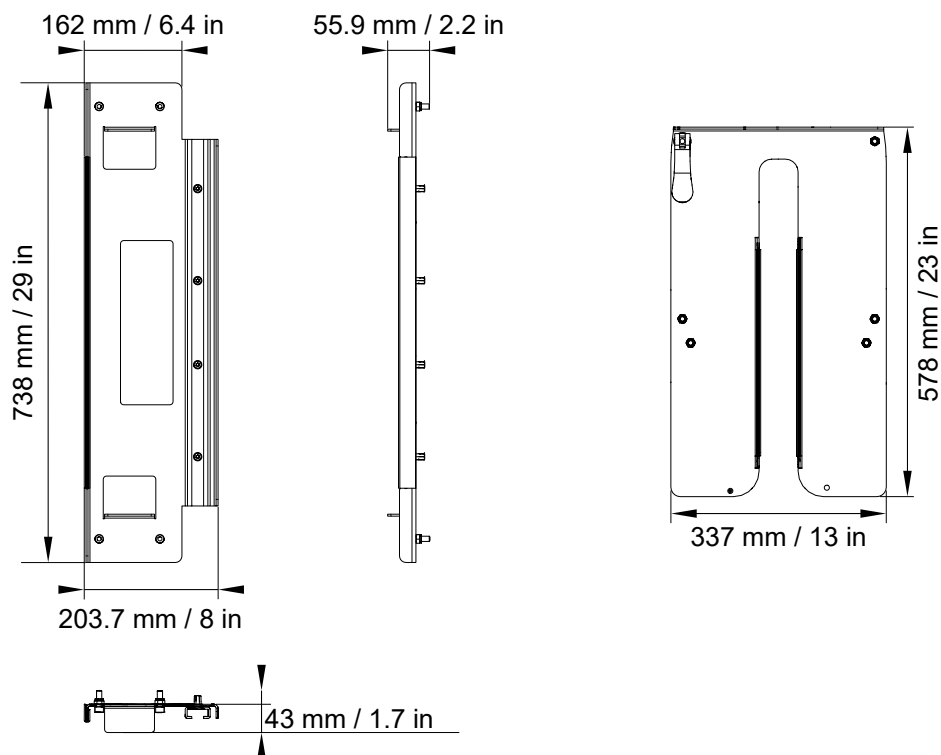

## CLAMP1000-BASE specifications

---

<b>Description</b>	CLAMP1000 rotary base certified for 1000 kg / 2205 lb
<b>Weight (net)</b>	15 kg / 33 lb
<b>Material</b>	high grade steel with anti-corrosion coating

## CLAMP1000-BASE dimensions

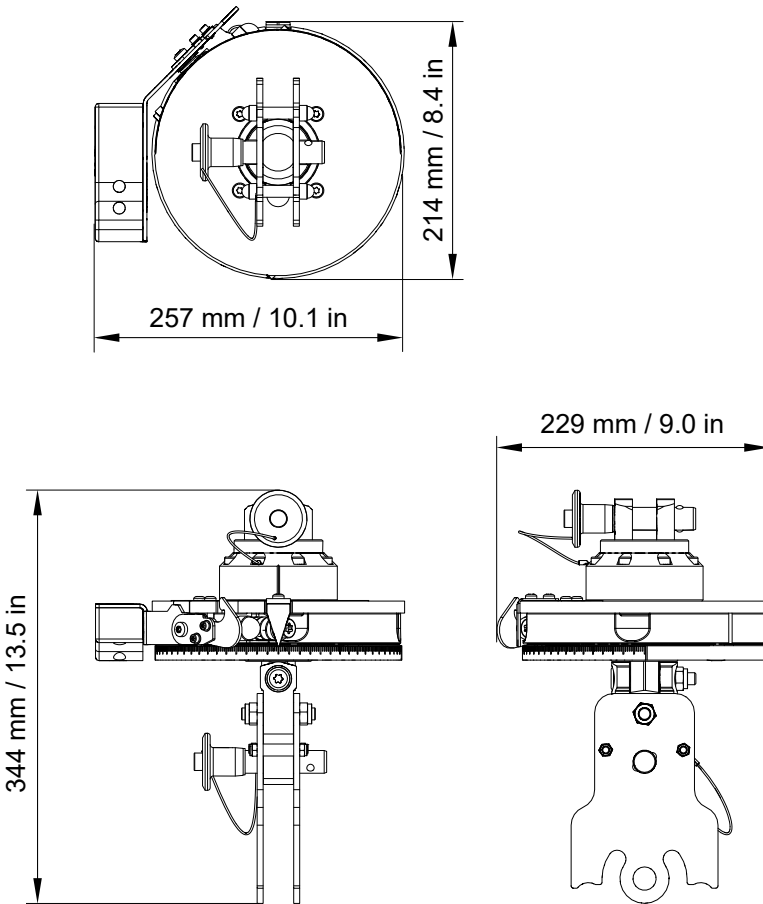

## CLAMP1000-SINGLE specifications

<b>Description</b>	Single point mounting adaptor for CLAMP1000-BASE
<b>Weight (net)</b>	2.0 kg / 4.4 lb
<b>Material</b>	high grade steel with anti-corrosion coating

## CLAMP1000-SINGLE dimensions

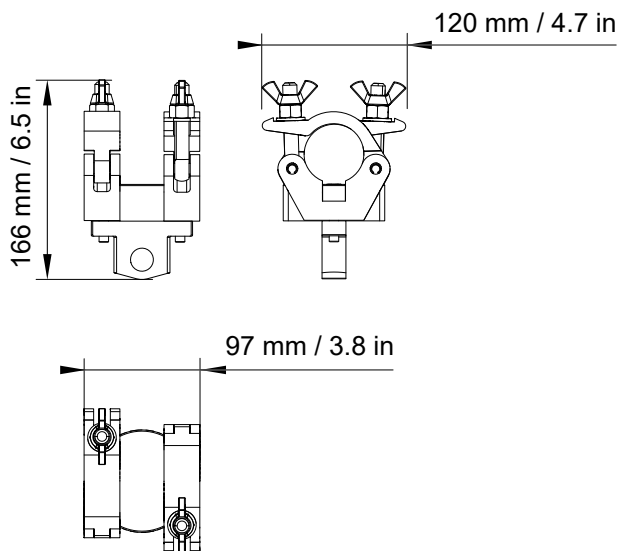

## Mounted on CLAMP1000-BASE

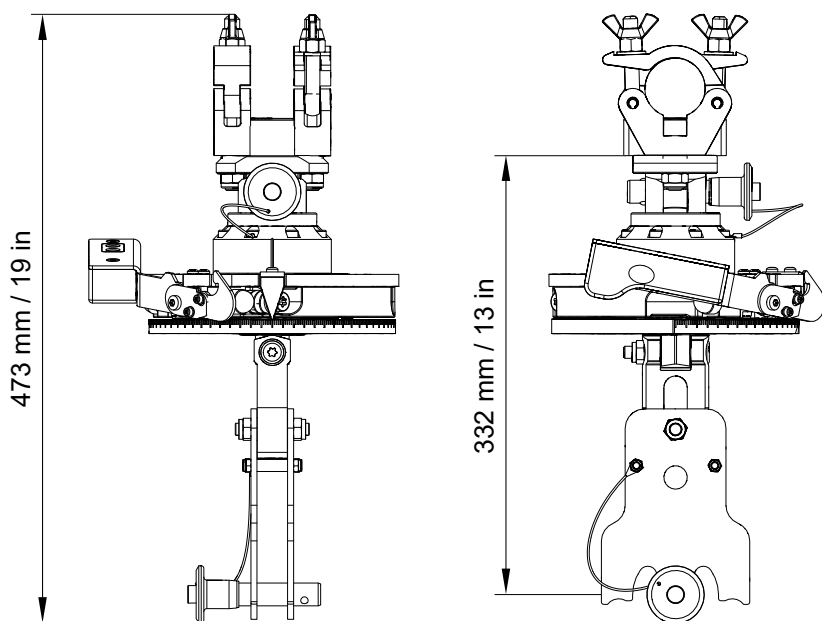

## CLAMP1000-DUAL specifications

---

<b>Description</b>	Dual point mounting adaptor for CLAMP1000-BASE
<b>Weight (net)</b>	14 kg / 31 lb
<b>Material</b>	high grade steel with anti-corrosion coating

## CLAMP1000-DUAL dimensions

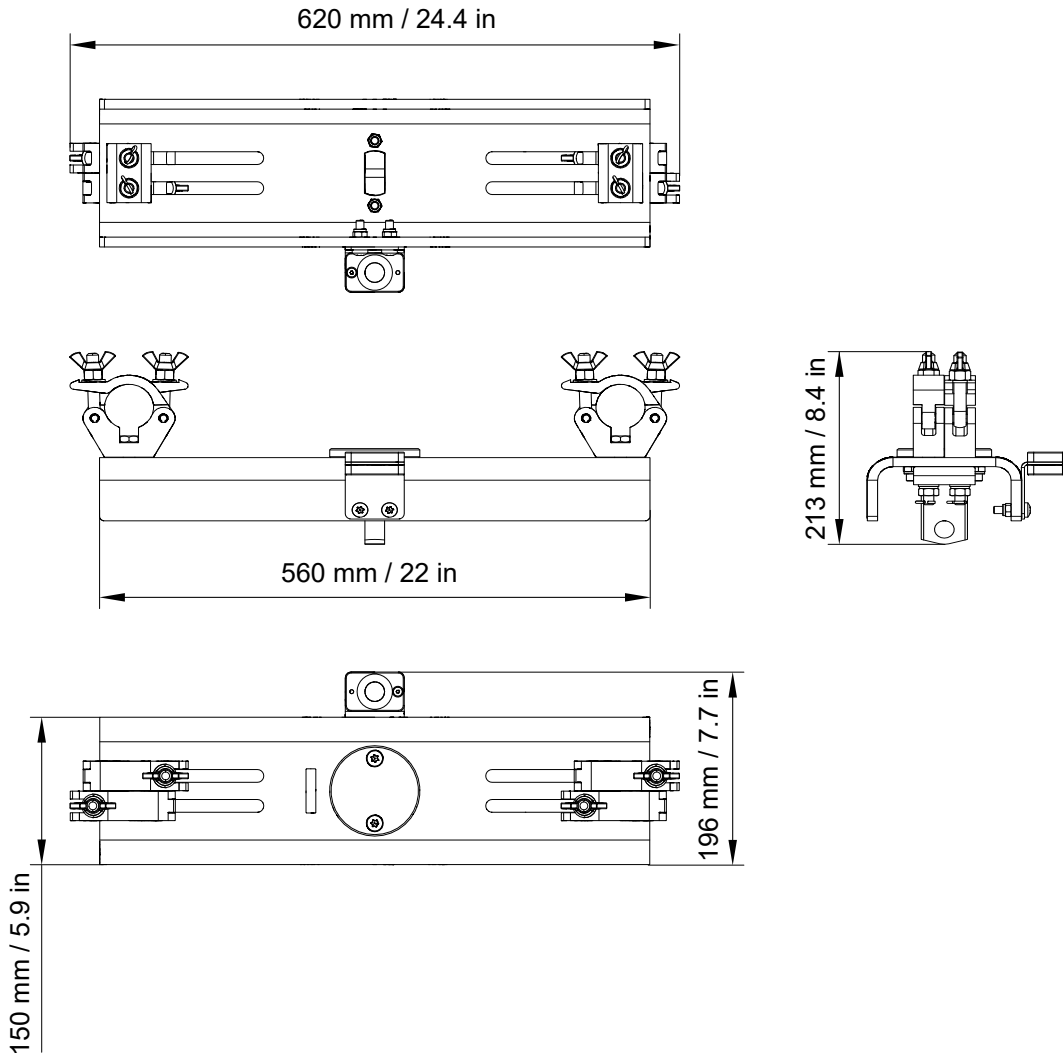

**Mounted on CLAMP1000-BASE**

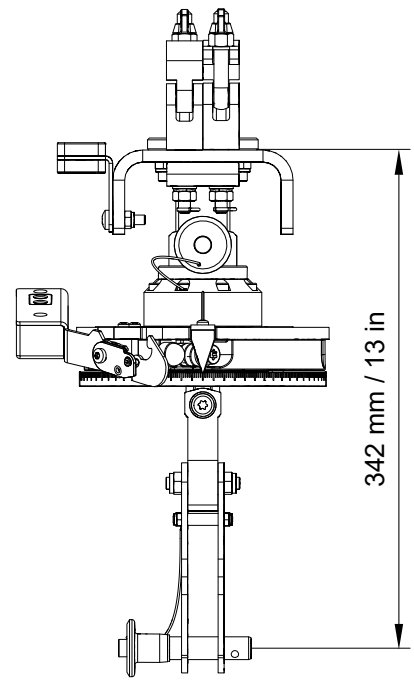
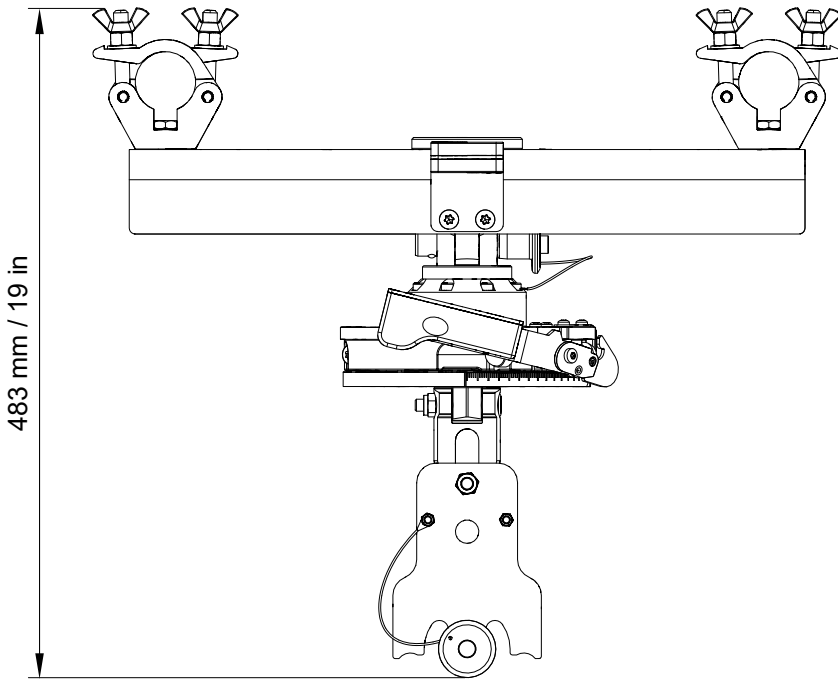

## CS1-CHARIOT specifications

---

<b>Description</b>	Chariot for up to four CS1
<b>Weight (net)</b>	70 kg / 154.3 lb
<b>Material</b>	aluminum

### CS1-CHARIOT dimensions

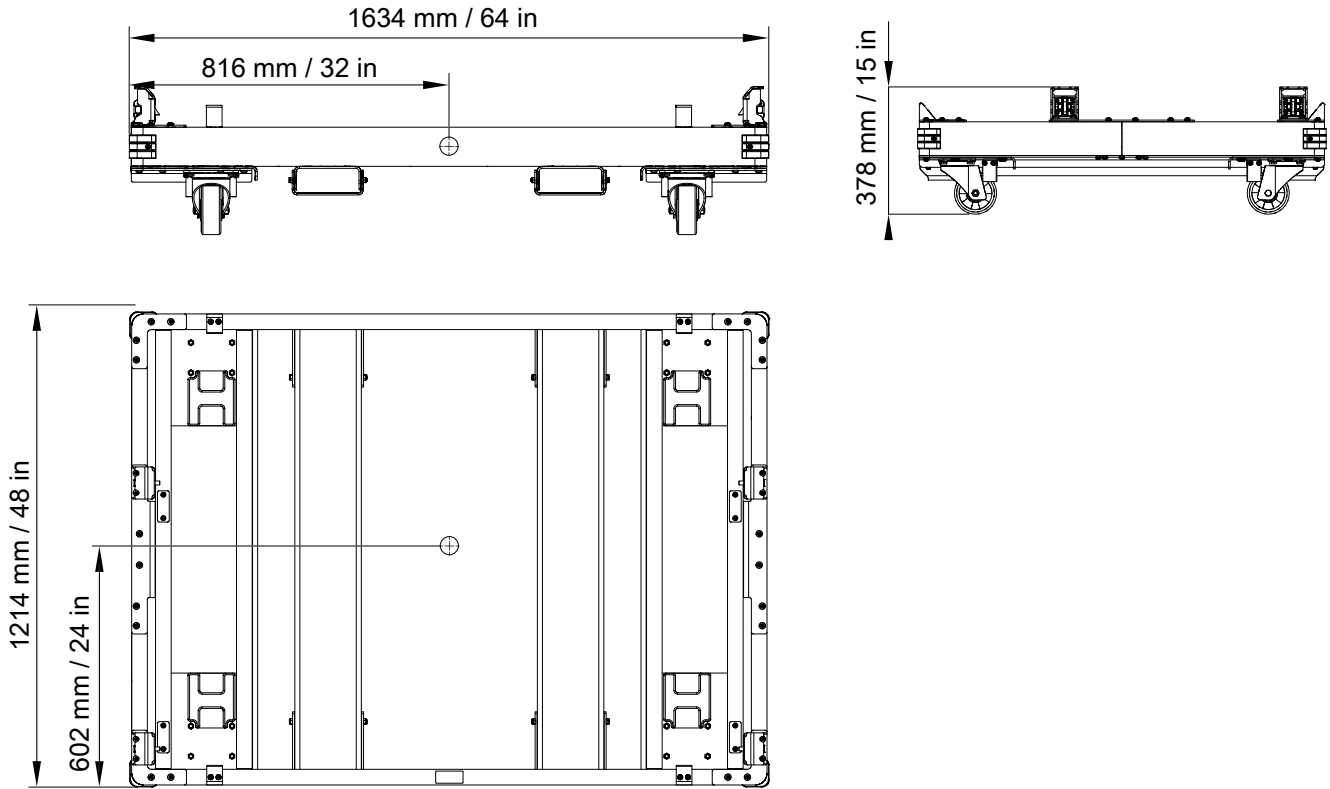

With CS1 secured on CS1-CHARIOT

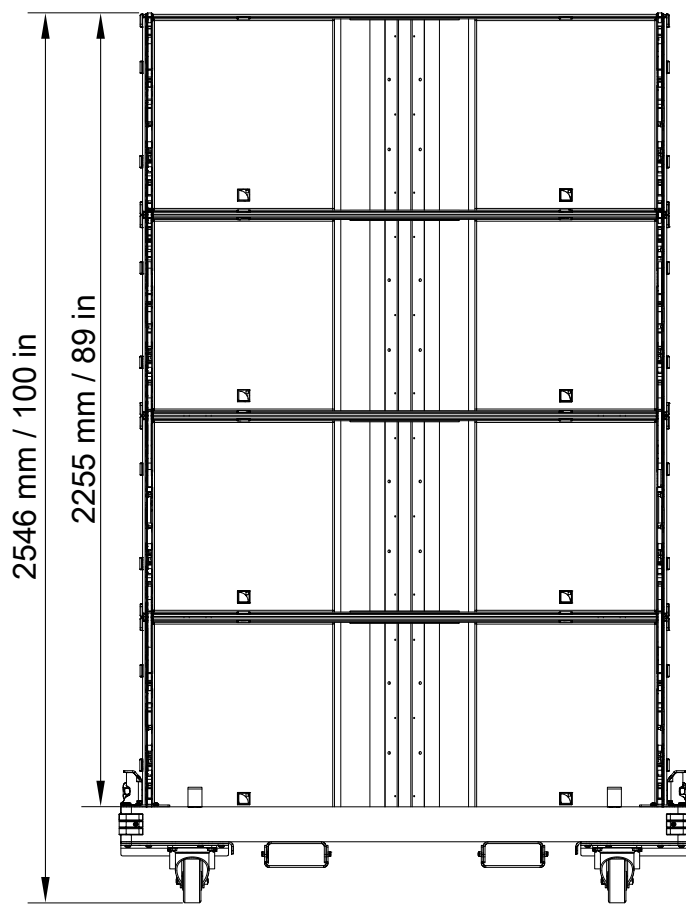
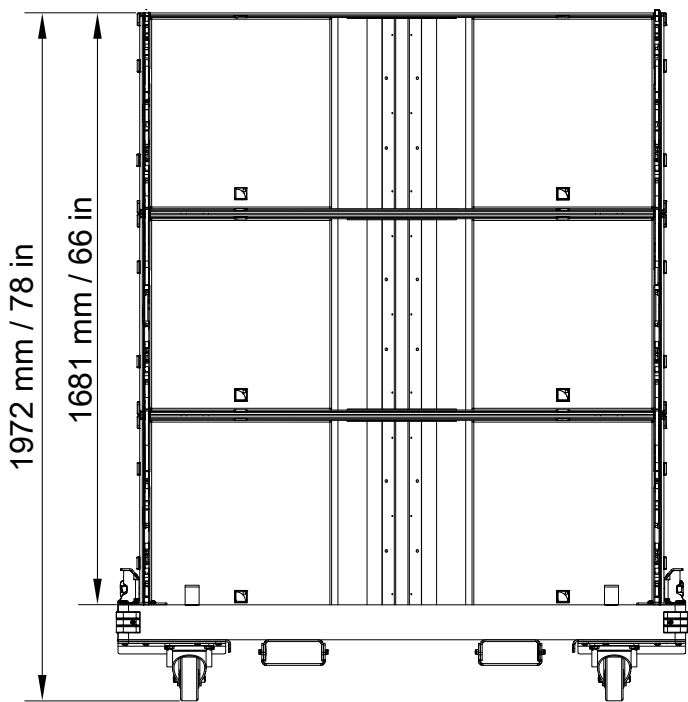
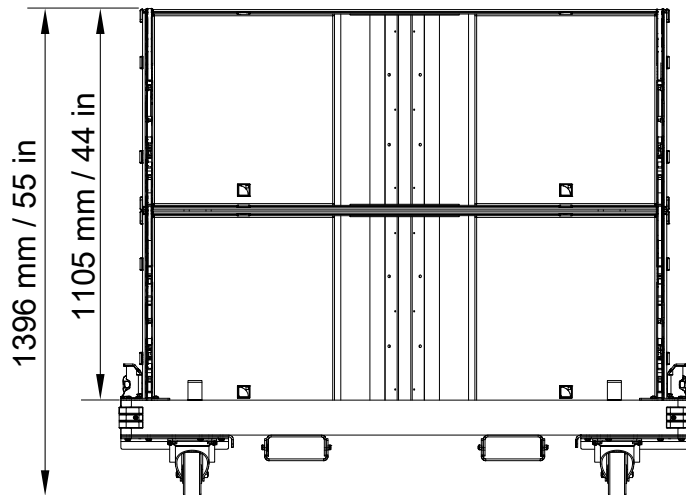
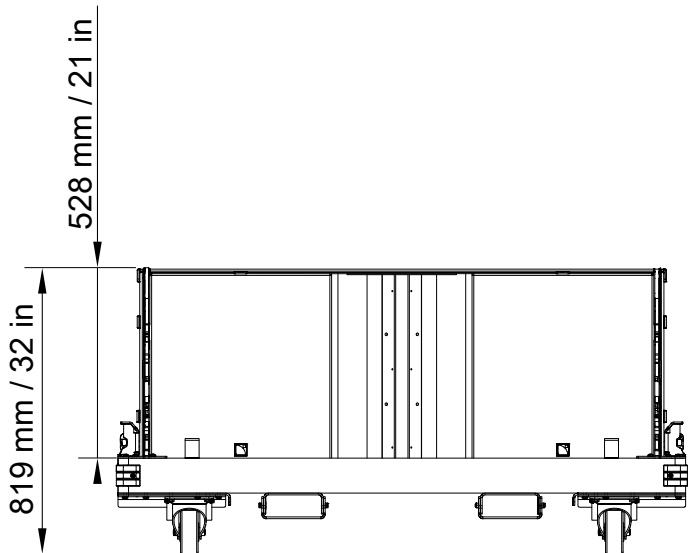

## CS1-PLA specifications

---

<b>Description</b>	Removable front dolly for one CS1
<b>Weight (net)</b>	17 kg / 37 lb
<b>Material</b>	high grade steel with anti-corrosion coating

### CS1-PLA dimensions

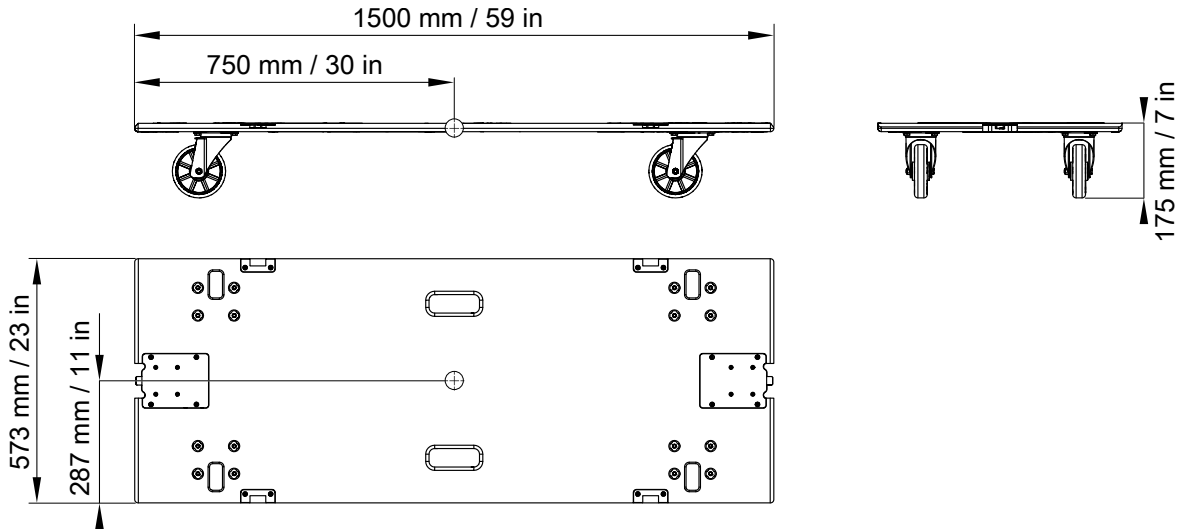

## L1CS1-BUMPFLIGHT specifications

---

<b>Description</b>	Modular flightcase for 2 L1-BUMP/CS1-BUMP and rigging elements
<b>Weight (net)</b>	124 kg / 273 lb
<b>Material</b>	high grade steel with anti-corrosion coating

### L1CS1-BUMPFLIGHT dimensions

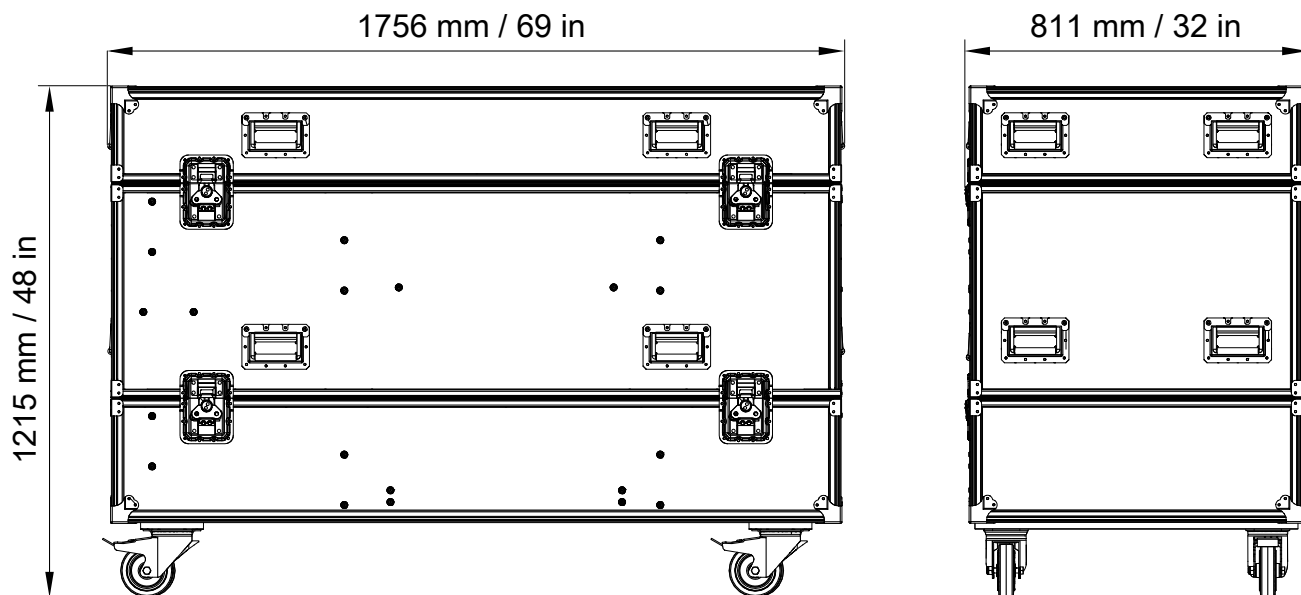

## L1CS1-BUMPFLIGHTADDLAYER specifications

<b>Description</b>	L1CS1-BUMPFLIGHT extension for one additional L1-BUMP/CS1-BUMP
<b>Weight (net)</b>	49 kg / 108 lb
<b>Material</b>	high grade steel with anti-corrosion coating

## L1CS1-BUMPFLIGHTADDLAYER dimensions

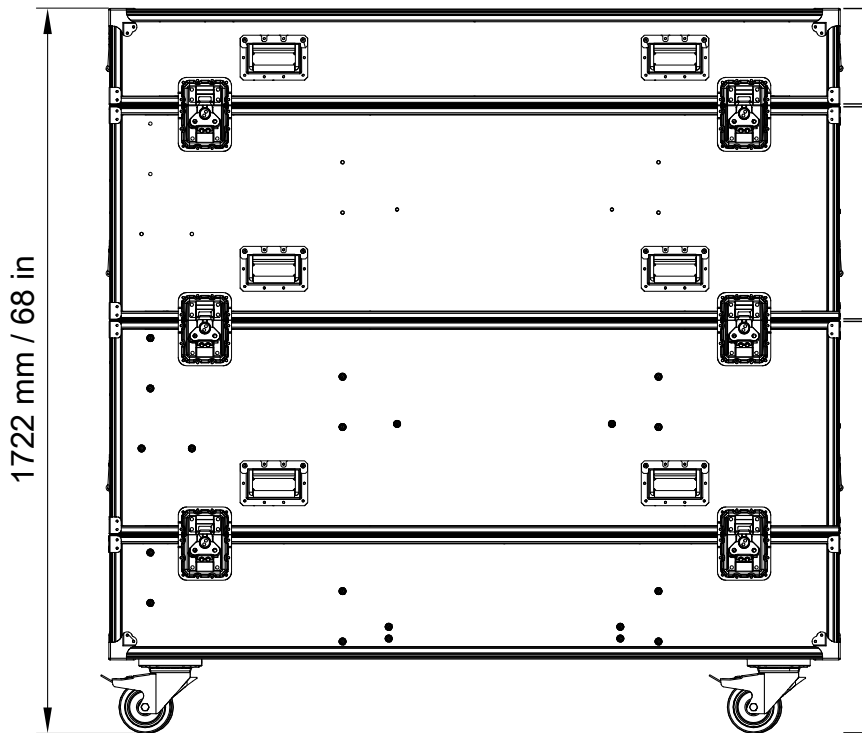
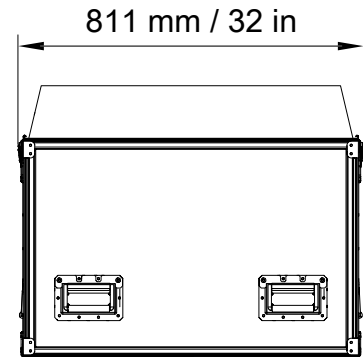
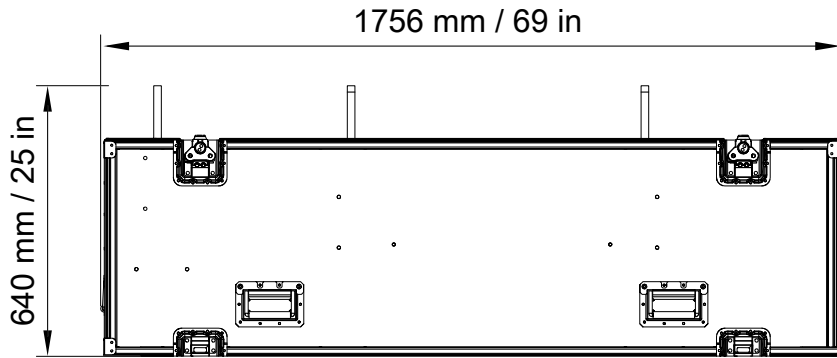

L1CS1-BUMPFLIGHT

L1CS1-BUMPFLIGHTADDLAYER

L1CS1-BUMPFLIGHT

## Recommendation for speaker cables



### Cable quality and resistance

Only use high-quality fully insulated loudspeaker cables made of stranded copper wire.

Use cables with a gauge offering low resistance per unit length and keep the cables as short as possible.

It is good practice to keep loudspeaker cables short to ensure optimal system performance. L-Acoustics strongly recommends using cables of similar type, length, and gauge to address symmetrical deployment of loudspeakers, such as stereo systems, L-ISA frontal systems, or outfill systems.



For more information about cable effect on loudspeaker frequency response, refer to the publication **Demystifying the effects of loudspeaker cables** on the L-Acoustics website, in **Education > Scientific resources > Scientific publications**.

Refer to the following table for recommended cable length for uncompromised performance.

cable gauge			recommended maximum length					
			8 Ω load		4 Ω load		2.7 Ω load	
mm <sup>2</sup>	SWG	AWG	m	ft	m	ft	m	ft
1.5	18	16	18	60	9	30	–	–
2.5	15	14	30	100	15	50	10	33
4	13	11	50	160	25	80	17	53
6	11	9	74	240	37	120	25	80

Use the more detailed L-Acoustics calculation tool to evaluate cable length and gauge based on the type and number of loudspeakers connected. The calculation tool is available on our website: <https://www.l-acoustics.com/installation-tools/>

## Installing a laser inclinometer

### L1-BUMP and CS1-BUMP

---

L1-BUMP and CS1-BUMP feature a plate to accommodate a laser inclinometer, using the L-Acoustics Tech Toolcase II accessories.

**i** The plate can be installed on either side of the L1-BUMP/CS1-BUMP central bar.

#### With LASER-MAGPLATE

Mount the inclinometer on the LASER-MAGPLATE:

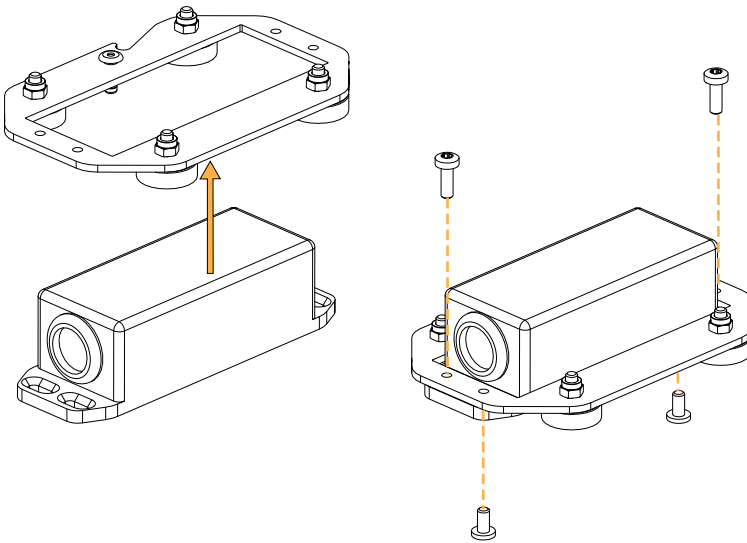

Position the magnetic LASER-MAGPLATE on L1-BUMP or CS1-BUMP :

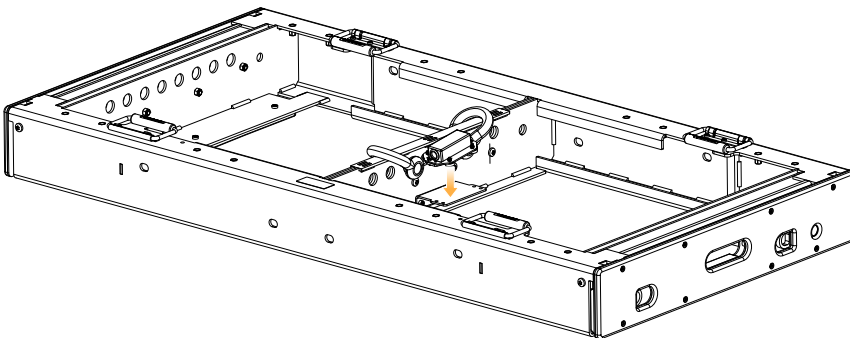

With L1-BUMP

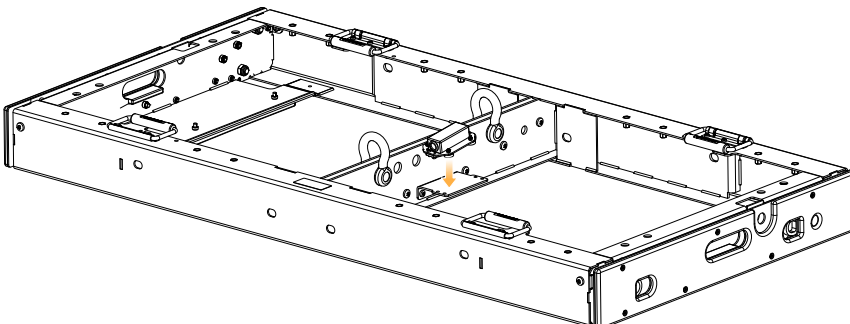

With CS1-BUMP

**With screws**

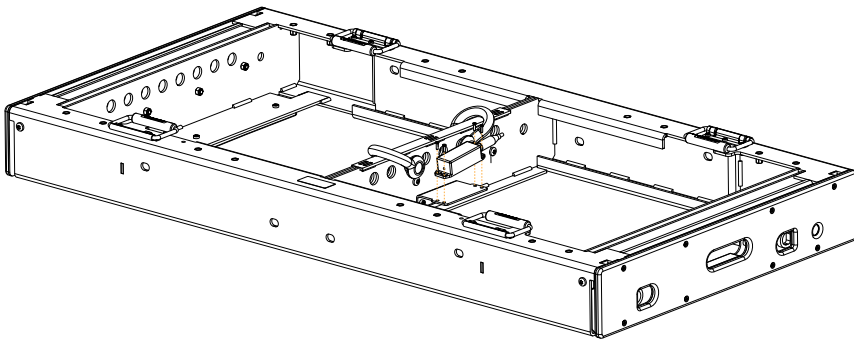

**With L1-BUMP**

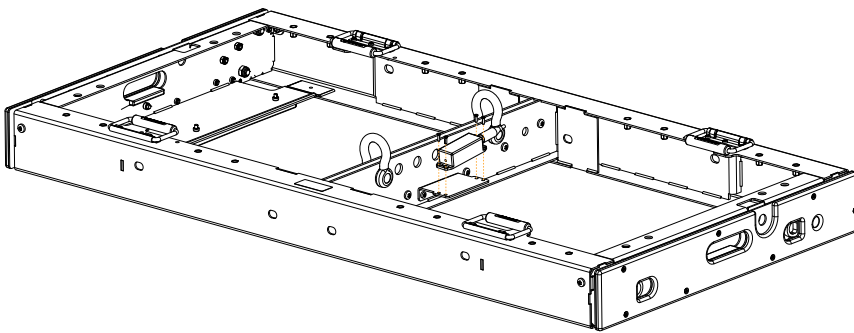

**With CS1-BUMP**



**L-ACOUSTICS**

**L-Acoustics**

13 rue Levacher Cintrat - 91460 Marcoussis - France

+33 1 69 63 69 63 - [info@l-acoustics.com](mailto:info@l-acoustics.com)

[www.l-acoustics.com](http://www.l-acoustics.com)

 **L-ACOUSTICS**  
GROUP